

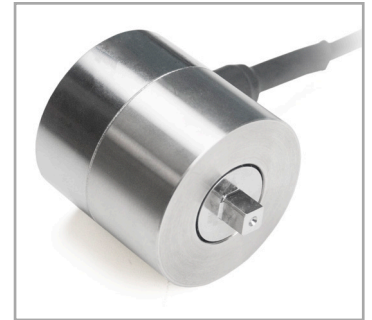

▲ Female square drive on side 1



▲ Male square drive on side 2

This rugged series of torque sensors is ideal for a wide range of torque testing applications in numerous industries. Square drives on both ends permit inline use with a torque wrench, or for use in OEM and other applications. Capacities available from 20 to 5,000 lbFin (2 to 550 Nm). Compatible with Mark-10 indicators (sold separately) through unique Plug & Test® technology. Includes a certificate of calibration with data.

## Specifications

<b>Accuracy:</b>	±0.6% of full scale + indicator
<b>Safe overload:</b>	150% of full scale
<b>Weight:</b>	MR55-20 - MR55-1000: 1.3 lb [0.6 kg] MR55-5000: 1.9 lb [0.9 kg]



Unique Plug & Test® technology allows for interchangeable sensors to be used with a Mark-10 indicator. All calibration and configuration data is saved in the smart connector.



The Plug & Test® connector locks into the receptacle in the indicator when fully inserted. Dual buttons on the indicator housing release the connector for easy removal. Gold plated spring contacts ensure long lasting and reliable connection.

Mark-10 Corporation  
11 Dixon Avenue, Coppage, NY 11726 USA Tel: 815-842-9200 Email: info@mark-10.com

**CERTIFICATE OF CALIBRATION**  
LONG FORM

MODEL NO.	M5-100	RELATIVE HUMIDITY (%)	47%
SERIAL NO.	2942058	TEMPERATURE (°F)	70.0 °F
DESCRIPTION	DIGITAL FORCE GAUGE	TOLERANCE (μF)	0.1
CAPACITY	100 LBF	RESOLUTION	0.02

READING NUMBER	MASTER READING	TENSOMETER CLOUSE	ERROR %	COR. COUNTER	ERROR %
1	10.00	10.02	0.02	1	0.02
2	20.00	20.02	0.02	20	0.02
3	30.00	30.02	0.02	30.02	0.02
4	40.00	40.04	0.04	40.04	0.04
5	50.00	50.04	0.04	50.04	0.04
6	60.00	60.04	0.04	60.04	0.04
7	70.00	70.02	0.02	70.02	0.02
8	80.00	80.02	0.02	80.02	0.02
9	90.00	90.00	0.00	90.00	0.00
10	100.00	100.00	0.00	100.00	0.00

TENSOMETER - CLOUSE

COMPRESSION - COUNTER CLOUSE

We hereby certify that the above instrument was calibrated according to procedures traceable to the National Institute of Standards & Technology (NIST) utilizing calibration equipment traceable to the requirements of ISO 9001:2008 and ISO/IEC 17025:2005. One or more of the below listed NIST traceability numbers apply:

70714-021 70714-022 70714-023 70714-024 70714-D25 70714-D26  
70118-A16 70714-D30 70714-027 70118-A15 70714-D31

By: \_\_\_\_\_ Date: \_\_\_\_\_

Included certificate of calibration contains 10 data points in each measuring direction.

## Dimensions in [mm]

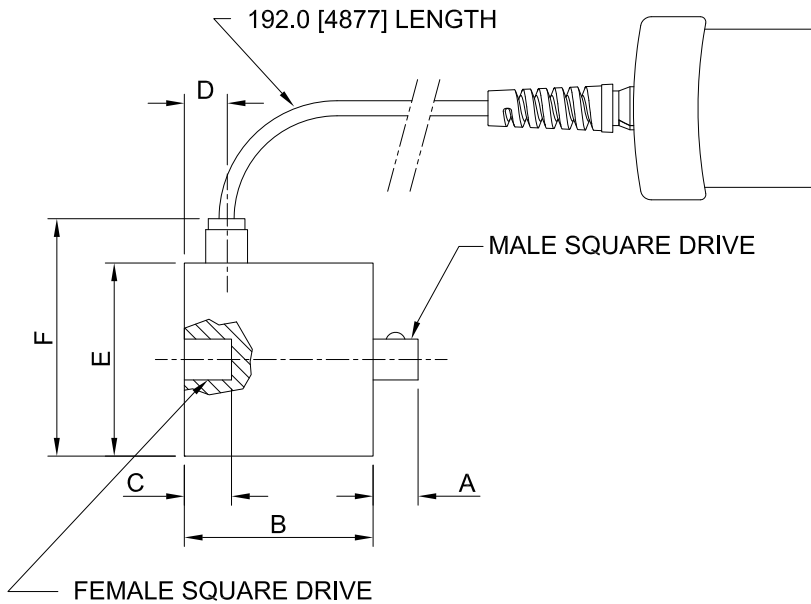

Model No.	Drive Size	A	B	C	D	ØE	F
MR55-20 - MR55-100	1/4"	0.30 [0.75]	1.73 [44.0]	0.32 [8.0]	0.39 [10.0]	1.77 [45.0]	2.32 [59.0]
MR55-200 - MR55-400	3/8"	0.41 [10.5]	1.73 [44.0]	0.43 [11.0]			
MR55-1000	1/2"	0.59 [15.0]		0.63 [16.0]			
MR55-5000	3/4"	0.89 [22.5]	2.11 [53.5]	0.94 [24.0]	0.77 [19.5]	2.01 [51.0]	2.56 [65.0]

## Capacity x Resolution

Model No.	With Models M71 & M51 indicators						With Model M31 indicator			
	lbFin	ozFin	lbFft	kgFmm	Ncm	Nm	lbFin	ozFin	kgFmm	Ncm
MR55-20	20 x 0.02	320 x 0.2	1.5 x 0.002	-	220 x 0.2	2 x 0.002	20 x 0.02	320 x 0.5	-	220 x 0.2
MR55-50	50 x 0.05	800 x 0.5	4 x 0.005	-	570 x 0.5	5.7 x 0.005	50 x 0.05	800 x 1	-	570 x 0.5
MR55-100	100 x 0.1	1600 x 1	8 x 0.01	-	1150 x 1	11.5 x 0.01	100 x 0.1	1600 x 2	-	1150 x 1
MR55-200	200 x 0.2	-	16 x 0.02	2300 x 2	2200 x 2	22 x 0.02	200 x 0.2	-	2300 x 2	2200 x 2
MR55-400	400 x 0.5	-	32 x 0.05	4600 x 5	4500 x 5	45 x 0.05	400 x 0.5	-	4600 x 5	4500 x 5
MR55-1000	1000 x 1	-	80 x 0.1	11500 x 10	11000 x 10	110 x 0.1	1000 x 1	-	11500 x 10	11000 x 10
MR55-5000	5000 x 5	-	400 x 0.5	55 x 0.05 kgFm	55000 x 50	550 x 0.5	5000 x 5	-	55 x 0.05 kgFm	550 x 0.5 Nm