



Series TT02 is shown in a typical manual torque screwdriver test

Series TT02 Torque Tool Testers present a simple and accurate solution for testing manual, electric, and pneumatic torque screwdrivers, wrenches, and other tools. These testers are compact and rugged, suitable for production environments. A universal 3/8" square receptacle accepts common bits and attachments. The TT02 captures peak torque in both measurement directions, and also calculates 1st and 2nd peaks, useful for click-type tools.

A blazingly fast sampling rate of 7,000 Hz and accuracy of  $\pm 0.3\%$  produce reliable and consistent test results. The TT02 includes a range of sophisticated productivity-enhancing features, including USB, RS-232, Mitutoyo, and analog outputs, automatic data output/zeroing/data storage upon tool slip or click, memory storage for 1,000 readings, pass/fail indicators and outputs, and more. Password protection is provided to prevent unauthorized changes to settings and calibration.

Series TT02 testers include MESUR<sup>®</sup> Lite data acquisition software. MESUR<sup>®</sup> Lite tabulates continuous or single point data. Data stored in the TT02's memory can also be downloaded in bulk. One-click export to Excel allows for further data manipulation.

Note: Not compatible with impact tools.

MESUR Lite data acquisition software is included with Series TT02 testers

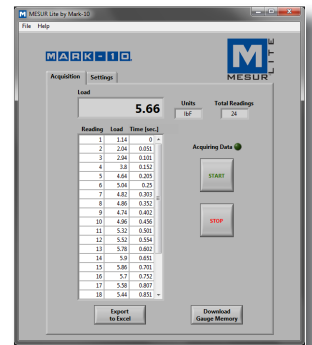

## Features

- First / second peak capture for CW and CCW directions
- 3/8" square receptacle accommodates common bits and attachments
- High-speed 7,000 Hz sampling rate accurately captures peak torque values
- 1,000-point data memory with statistics and outputs
- USB, RS-232, Mitutoyo, and analog outputs
- Break detection: automatic output, data storage, and zeroing upon tool click/slip automates testing processes
- Programmable set point indicators and outputs for pass/fail determination
- Password protection prevents unauthorized changes
- 5 selectable units of measurement
- MESUR<sup>®</sup> Lite data collection software included

## Controls & Indicators

Series 3

- Set points
- Current or peak reading
- Set point (pass/fail) indicators
- Battery indicator
- Memory storage for 1000 readings (auto-save also possible)
- Access the tester's settings menu via an easy-to-use interface
- One-push data output to a PC, printer, or other device (auto-output also possible)
- Clockwise/counter-clockwise indicator
- Peak readings (CW/CCW or 1st/2nd peaks)
- Measurement mode
- Unit of measurement
- Analog load bar w/set point markers
- Zero the reading to begin a new test (auto-zero also possible)
- Toggle between real time, peak, and 1st peak/2nd peak display modes

## Optional Items



### AC1066-1 & AC1066-2 Rundown fixtures

Provide accurate and consistent torque measurements for electric and pneumatic tools. Select AC1066-1 to simulate a soft joint with gradual torque buildup or AC1066-2 to simulate a hard joint with faster torque buildup. Integrated 3/8" square drive.



### ST001 Bench mounting kit

Mounts the TT02 securely to a bench for horizontal orientation.



### ST002 Carrying case

Provides storage space for the TT02 tester, rundown fixtures, bench mounting kit, AC adapter, and accessories.

## Specifications

<b>Accuracy:</b>	±0.3% of full scale
<b>Sampling Rate:</b>	7,000 Hz
<b>Power:</b>	AC adapter: 100-240VAC, 50-60 Hz, 0.3 A Battery: Rechargeable 8.4V NiMH Low battery indicator appears when battery level is low, and gauge powers off automatically when power reaches critical stage.
<b>Battery life:</b>	<b>Backlight on:</b> up to 7 hours of continuous use <b>Backlight off:</b> up to 24 hours of continuous use
<b>Units:</b>	ozFin, lbFin, kgFcm, Nm, Ncm
<b>Outputs:</b>	<b>USB / RS-232:</b> Configurable up to 115,200 baud. <b>Mitutoyo:</b> Serial BCD suitable for all Mitutoyo SPC-compatible devices. <b>Analog:</b> ±1 VDC, ±0.25% of full scale at capacity. <b>General purpose:</b> Three open drain outputs, one input. <b>Set points:</b> Three open drain lines.
<b>Configurable settings:</b>	1st/2nd peak, digital filters, outputs, automatic shutoff, default settings, key tones, backlight, audio alarms, passwords, calibration
<b>Safe overload:</b>	150% of full scale (display shows "OVER" at 110% and above)
<b>Weight:</b>	5.8 lb [2.6 kg]
<b>Environmental requirements:</b>	40 - 100°F, max. 96% humidity, non-condensating
<b>Warranty:</b>	3 years (see individual statement for further details)

## Dimensions in [mm]

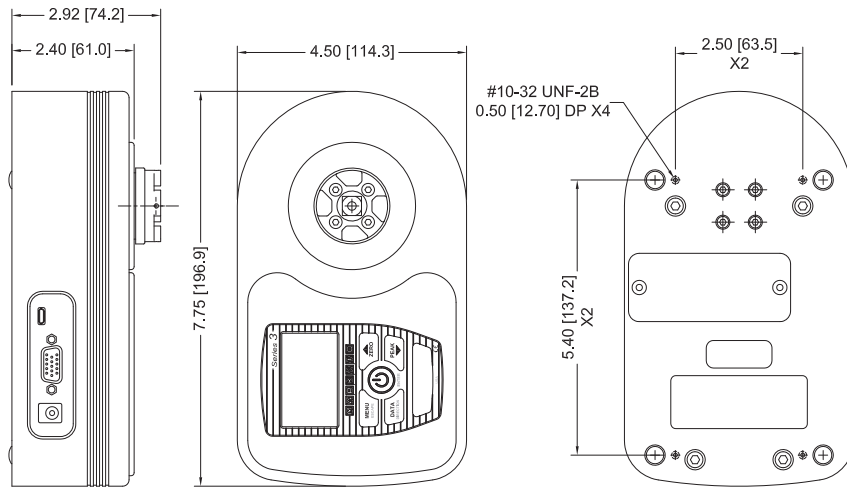

**RECEPTACLE TOP VIEW:**

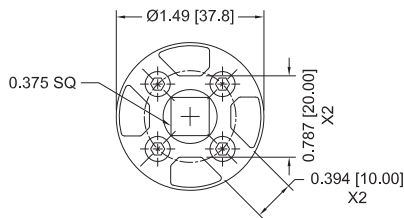

## In The Box

Series TT02 torque testers are shipped as shown at right, and include the following accessories:

- (1) 1/4" hex to 3/8" square adapter
- (1) USB cable
- (1) AC adapter
- (1) Battery
- (1) Certificate of calibration without data (data is optional)



## Capacity x Resolution

Model No.	ozFin	lbFin	kgFcm	Ncm	Nm
MTT02-12	192 x 0.1	12 x 0.005	14 x 0.01	135 x 0.1	1.35 x 0.001
MTT02-25	400 x 0.2	25 x 0.01	28 x 0.02	290 x 0.2	2.9 x 0.002
MTT02-50	800 x 0.5	50 x 0.02	58 x 0.05	570 x 0.5	5.7 x 0.005
MTT02-100	1600 x 1	100 x 0.05	116 x 0.1	1150 x 0.5	11.5 x 0.005

All models include 110V AC adapters. Add suffix 'E' for euro plug (220V), 'U' for UK plug (220V), or 'A' for Australian plug (220V).

Ex: MTT02-12E, MTT02-50U, MTT02-100A