

FORCE AND MATERIAL TESTING

Digital Force Gages

Mechanical Test Stands

Motorized Test Stands

Software

Load Cells

Accessories

Applications

Services



PRECISION, QUALITY, INNOVATION

For more than 135 years, manufacturers, builders and craftsmen worldwide have depended upon tools from the L.S. Starrett Company to ensure the consistent quality of their manufacturing processes.

They know that the Starrett name on force and material testing, precision hand tools, metrology equipment, hand tools, power tool accessories, saws, laser measurement, and gage blocks means exceptional quality, innovative products and expert technical assistance.

With strict quality control, state-of-the-art equipment and an ongoing commitment to producing products with superior quality, the 5,000 plus products in today's Starrett line continue to be the most accurate, robust and durable tools available.

This catalog features Starrett Force and Material Testing Systems, their applications and characteristics.



DIGITAL FORCE GAGES

Digital Force Gages available in 2lbf to 500lbf capacities, for hand held use, manual force stands or motorized force stands.

13



MANUAL FORCE STANDS

Manual force stands available in three capacities, 110lbf, 330lbf and 550lbf for use of the Digital Force Gages

19



MOTORIZED TEST STANDS

Material Measurement and force measurement test frames available in 500N, 1000N, 2500N, 5kN, 10kN, 30kN, and 50kN capacities.

23



FORCE AND MATERIAL TESTING

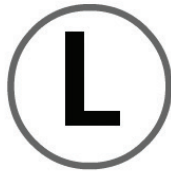

Series

MetLogix

SOFTWARE

- L3 - 28
- L2 Plus - 32
- L1 - 40
- Automation Builder - 50

33



LOAD CELLS

Starrett load sensors are supplied with a NIST-traceable Certificate of Calibration. All sensor types are "plus and play" and are available in 5N to 50kN capacities.

53



WARNING
 Crush hazard.
 Keep hands clear.
 Lock-out / tag-out
 before servicing.

Starrett
 FMS5000

PLATENS

Made from aluminum and steel for compression applications; available in fixed or self-leveling for soft samples, cardboards, plastics, steel, stone, foam, and more.

57



ECCENTRIC ROLLERS

An excellent self-tightening fixture for materials that deform under load, idea for flat samples, rollers available in smooth, rubber, or serrated jaw faces.

67

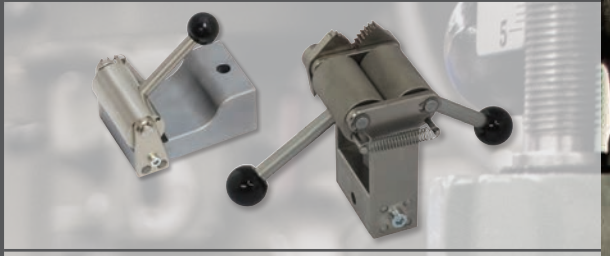

WISE-ACTION FIXTURES

A very easy sample loading option, these grips are tightened manually and keep alignment simple, jaw faces come in a variety of sizes and surface finishes.

73



WEDGE-ACTION FIXTURES

Designed for easy loading and alignment these fixtures can be equipped with smooth, serrated, v-notch, diamond-coated and rubber jaw faces. Wedge-action fixtures apply an increasing clamping pressure on the sample as they are pulled axially.

93



ROPE AND BOLLARD FIXTURES

Use these for testing materials like rope, cable, filaments, yarn and more. They are designed to ensure proper sample alignment and promote a correct sample break.

99



BUTTON FIXTURES

These fixtures are designed to test the tensile strength of electrical connectors such as wire connectors that are crimped on to wires.

105

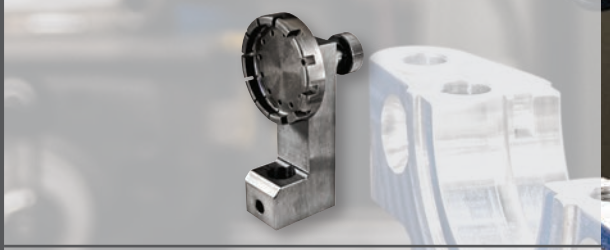

FLEXURAL FIXTURES

Used in 3 and 4 point bending testing a flexible testing solution with adjustable spans. Determine strength, deformation, or even flexural modulus with these grips.

107

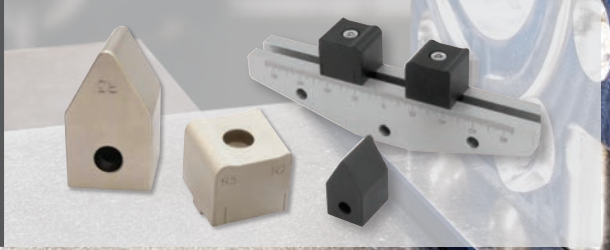



PEEL FIXTURES

These are suitable for determining adhesive strength on a variety of adhesive tapes, thin film coatings, copper runners and more. Fixed 90° and adjustable models are available.

111

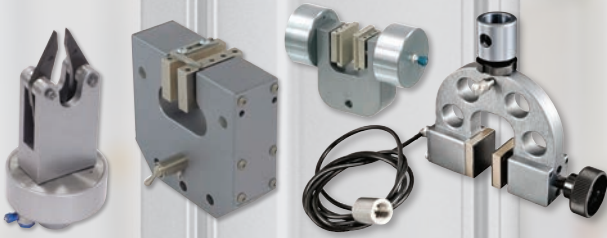

PNEUMATIC FIXTURES

Pneumatic actuation is used to open and close the jaw faces on these grips, ideal for high volume testing and maintaining a consistent clamping pressure.

119



SPRING TEST FIXTURES

Custom solutions for tension and extension springs, these ensure correct axial alignment for accurate measurements of spring constants, initial tension and free length.

143



SYRINGE TEST FIXTURES

These are designed to make loading and unloading easy, test in tension and compression, stand sizes available or custom on request.

145



SCISSOR FIXTURES

Self-tightening grips with a large variety of jaw faces available, great for general purpose testing of elastomers, plastic, rubber, textiles and more.

147



COEFFICIENT OF FRICTION (COF)

These fixtures meet ASTM, TAPPI, and ISO application standards for determining COF and films, substrates, ceramics, and slip resistant finishes.

151



FOOD TEXTURE FIXTURES

Use these fixtures to measure food characteristics like shear, brittleness, softness, crispness and more.

155

HOOK ADAPTERS

A good general purpose option available in clevis and threaded mounting options.

161



CLEVIS ADAPTERS

Used to secure most of the testing fixtures available to the test frame and the load cell in Starrett systems, these provide a quick and easy way of swapping setups.

165



FORCE GAGE ADAPTERS

These are used to mate dissimilar threaded connections available in male-to-male and male-to-female.

169

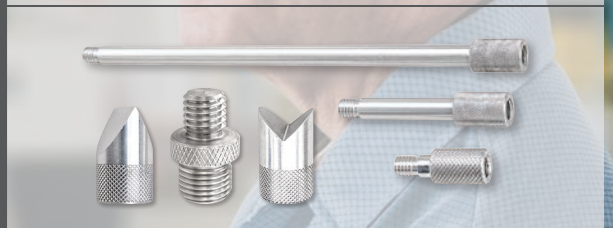

CABLES

For data exporting, or communications between DFx hand-held force gages and test frames.

173



GAGE ADAPTER PLATES AND MOUNTING BLOCKS

Adapter plates for mounting competitive gages to the Starrett FMM motorized force test frame.

Mounting block options for L1 systems and FMM motorized force test frame.

175



TESTER ACCESSORIES

Bench clips for motorized stands and horizontal legs for manual stands.

177

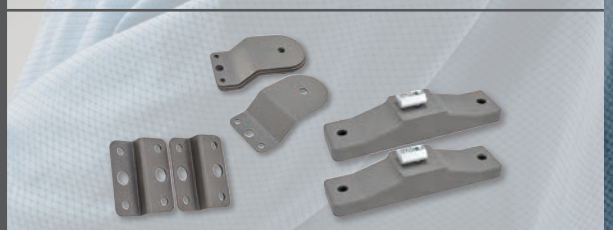

SAFETY SHIELDS & EXTENSOMETERS

179





APPLICATIONS

181



SERVICES

186

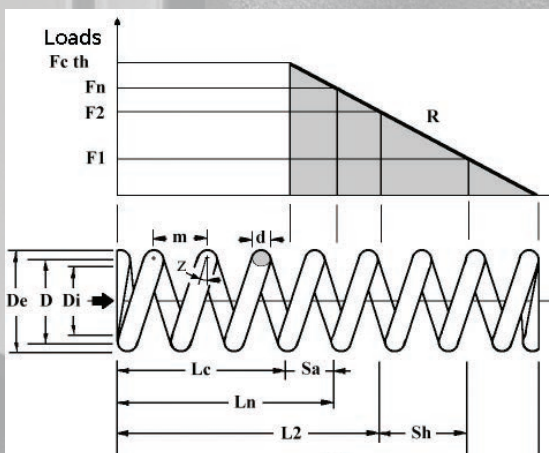

TERMINOLOGY

187

PRODUCT LINES

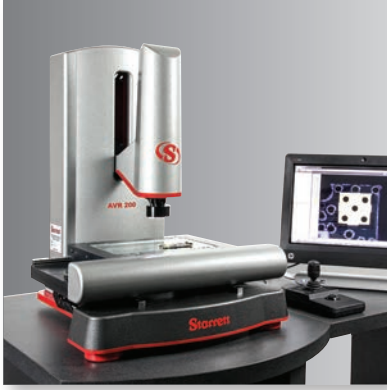

Vision Systems

Starrett vision systems combine high-resolution images with robust, precision mechanical platforms. We offer a full range of systems from video microscopes to large 50 x 36" (1270 x 915mm) platform systems and our Mx digital metrology software.



Granite Surface Plates

Starrett granite surface plates are available in three levels of accuracy: Grade AA (Laboratory), Grade A (Inspection) and Grade B (Tool room). Our Crystal Pink granite has the highest percentage of quartz of any granite so it has the best balance of physical properties, maximum resistance to wear and for deflection under load.



Indicators

Starrett manufactures an array of gages and indicators for exacting measuring applications. We offer test indicators, back plunger indicators, dial indicators, and accessories. We can supply analog and digital indicators, plus special application indicators for your application requirements.



Optical Comparators

Starrett optical comparators are ideal for a wide range of dimensional inspection applications. Starrett offers optical systems from 16-30" (400-750 mm) diameters, horizontal and vertical models.



Height Gages

For simple or complex height measurements, Starrett supplies a range of electronic height gages and accessories, including the DIGI-CHEK system- the world's fastest and most precise height masters.



Laser Measurements

Starrett is a leader in non-contact laser measurement systems such as our Profile 360 system. The system continuously monitors the size and shape of complex profiles to ensure quality and consistency in width, thickness, gap, radius, angle and more.



Bore Gages

Our AccuBore electronic bore indicators is a high-quality, trigger-activated, three-point contact bore gaging system. Starrett can supply a wide range of bore gage systems that ensure a more true alignment.



Webber Gauge Blocks

Starrett precision gage blocks are trusted for their accuracy, surface finish, wear resistance and dimensional stability. Our croblox® gage block is the world's premier gage block with industry-leading accuracy and stability.



Precision Tools

Starrett has a comprehensive range of micrometers and calipers that meet or exceed accuracy and performance specifications of national and international standards.

FACTORIES AROUND THE WORLD



1-Athol, Massachusetts, USA



2-Laguna Hills, California, USA



3-Waite Park, Minnesota, USA



4-Cleveland, Ohio, USA

FACTORIES



 Factories and Distribution Centers

 Starrett Distribution Centers and Offices



5-Mount Airy, North Carolina, USA



6-Columbus, Georgia, USA



7-Itu, São Paulo, Brazil



8-Jedburgh, Scotland



9-Suzhou, China



OVERVIEW

STARRETT INNOVATION. PRECISION.

ACCURACY. EASY TO USE.

Starrett offers a wide range of equipment that is easy to setup, operate, and maintain. These force and material measurement products includes hand held force gages, mechanical stands, motorized stands, and a complete range of software and accessory options suitable for any application.





DIGITAL FORCE GAGES

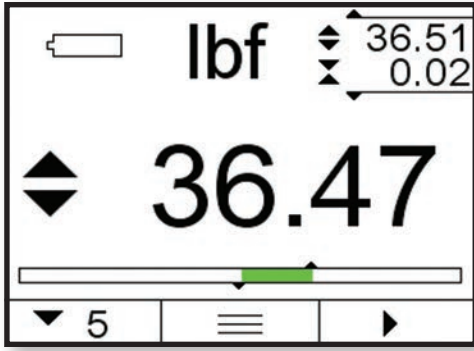

Real Time View

Primary window shows active load being applied to the load cell. The secondary window shows the measured peak in tension made - 36.51 lbf.

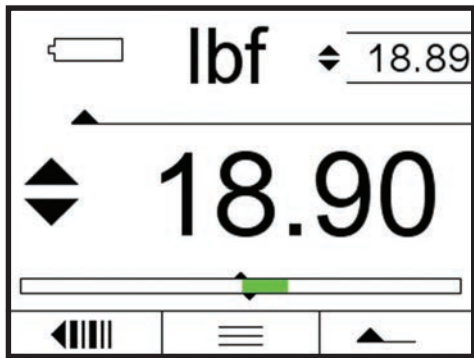

Tension Peak View

Shows maximum load measured in primary window. Secondary window shows real time load.

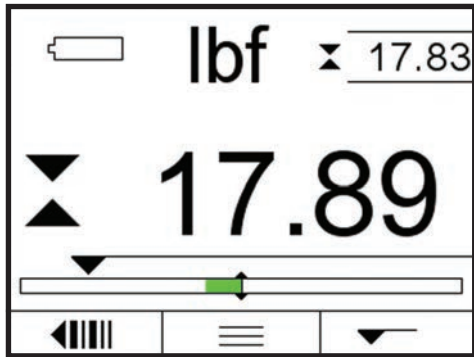

Compression Peak View

Shows maximum load measured in primary window. Secondary window shows real time load.

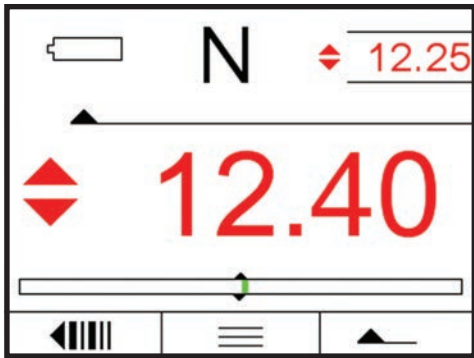

Tolerance View

When a tolerance is used, out-of-tolerance results display in red.

DFG DIGITAL FORCE CONTROLLER

The DFG is our basic force gage. The gage measures force at an accuracy of better than 0.2% full scale.

The DFG is ideal for basic tensile and compression testing. Test setup and operation is fast, efficient and easy for anyone. The DFG display shows the test direction and dynamic load during testing. Results are displayed at the completion of testing, including "Pass-Fail" when tolerance is applied. The gage will display statistics when results are saved to the gage's internal memory. Store up to 50 test results in local memory.



DFC DIGITAL FORCE CONTROLLER

The DFC is our advanced force gage. The gage measures force to an accuracy of better than 0.1% of full scale.

In addition to the DFG features, the DFC supports Bluetooth® output, 99 results saved in memory, and can be used to control the Starrett FMM motorized test for basic load distance and break testing.

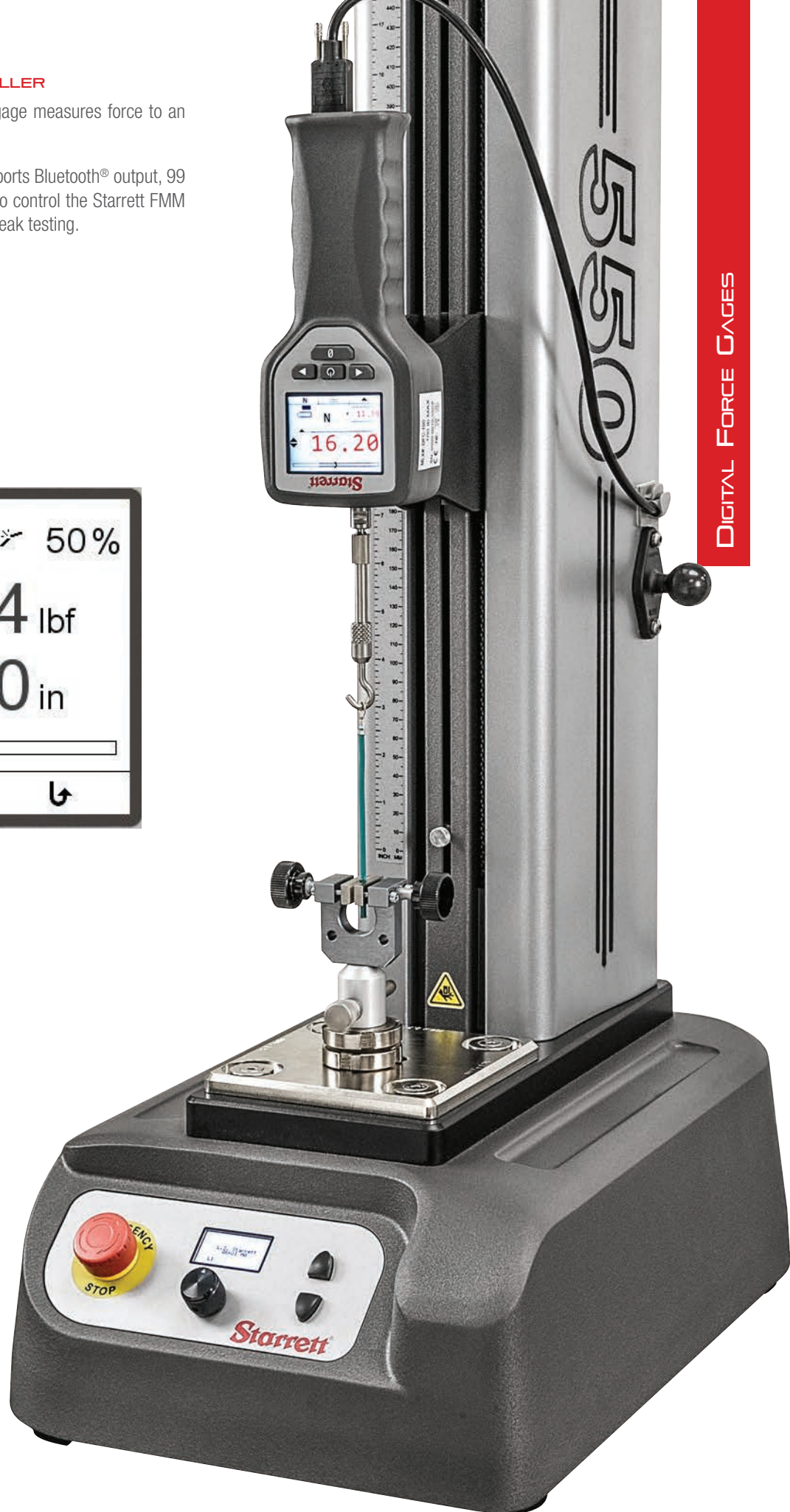
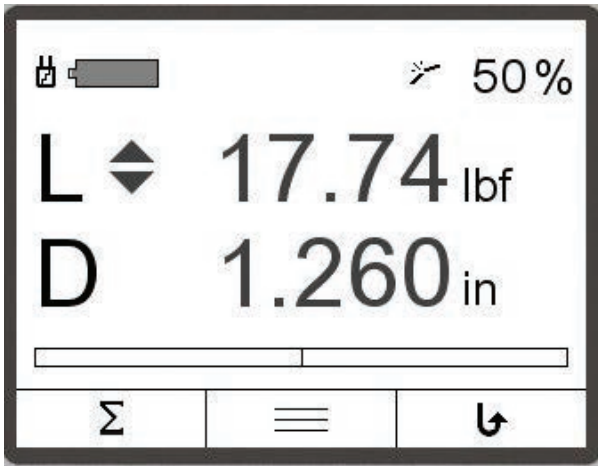

FEATURES

- Use as handheld instrument or mount to Starrett test frames: FMM, MTL and MTH.
- Excellent display resolutions:
 - DFC 10,000:1
 - DFG 5,000:1
- Precise and accurate load measurements:
 - DFC 0.1% full scale
 - DFG 0.2% full scale
- Load sensors have safe overload rating of 200%
- High-resolution OLED color display with adjustable backlight and Auto Off feature
- Supplied with NIST-traceable Certificate of Calibration
- 3-year warranty
- Metric threads for screw-on attachments. Can be fitted with clevis adapters that fit hundreds of Starrett test fixtures.
- A primary and secondary display window shows your results. Out-of-tolerance results display in red.
- Adjustable sampling rates help you capture peak loads. Filters can be applied to peak and display values.
- Multiple display languages.
- Battery provides more than 30 hours of continuous operation. Charge battery using USB cable.
- Change display (Flip feature) orientation without having to expose electronics.
- Easy-to-use multi-function keypad. Softkeys are programmable to your most used functions.
- Programmable sounds for alarms, such as an out-of-tolerance result
- Cast-aluminum housing
- Comfort grip for handheld testing applications.



The USB connection is used for charging the battery or for transmitting data to a personal computer. The RS-232 cable is used for connection to the FMM Digital Tester. The DFC also has Bluetooth®.



DIGITAL FORCE GAGES

SPECIFICATIONS

Digital Force Gages		
Specification	DFC	DFG
Accuracy, Full Scale	0.1%	0.2%
Data Sampling (Hz)	8,000	8,000
Display Resolution	10,000:1	5,000:1
Safe Overload, Full Scale	200%	200%
Maximum Tare	10%	10%
Communications		
Bluetooth®	Yes	No
USB 2.0	Yes	Yes
RS-232	Yes	Yes
Digital I/O	2 channels	No
Memory, maximum results saved in gage	99	50
Operating Mode		
Machine Control ¹	Yes	No
Real Time	Yes	Yes
Peak Compression	Yes	Yes
Peak Tension	Yes	Yes
Load Limit	Yes	Yes
Break Limit	Yes	No
Load Average	Yes	No
Load-Time Average	Yes	No
Power, Environmental		
Battery Type	Lithium Ion	
Battery Life, typical @ 20% brightness	>30 hours	
Charge Time, using 110/240V Mains	<3 hours	
Display	OLED High Resolution	
Operating Temperature	40°F to 110°F (4°C to 43°C)	
Thread, for adapters	Metric M6, M10	
Instrument Weight (approx.)	3lbs (1.36kgs)	

NOTES

1. Machine control is exclusive to the DFC. When connected to the FMM Digital Force Tester, configuration of force gage and tester is performed through the gage.

ACCESSORY KITS

The DFC and DFG Force Gages are supplied with a complete accessory kit. The kit includes a hook, notch, chisel, flat, and point adapter. A 6" extension rod is included. Adapter materials are stainless steel. Aluminum is used for 2lbf (10N) and 10lbf (50N) capacities.

Included with the force gage is a carrying case, USB cable, a set of testing accessories, a Quick Reference Guide and NIST-traceable Certificate of Calibration.



Force gage standard accessories

DFC - Advanced Force Controller										
Model No.	Load Capacity					Safe Overload % Full Scale	Full Scale Deflection		Thread mm	Accessory Kit
	N	KGf	LBF	OZF	GF		in	mm		
DFC-2	10	1	2	32	900	200	0.013	0.33	M6 x 1-6H	SPK-FG-A
DFC-5	20	2	5	80	2200	200	0.007	0.18	M6 x 1-6H	SPK-FG-A
DFC-10	50	5	10	160	5000	200	0.006	0.15	M6 x 1-6H	SPK-FG-S
DFC-20	100	10	20	320	10,000	200	0.008	0.20	M6 x 1-6H	SPK-FG-S
DFC-50	250	25	50	800	25,000	200	0.015	0.39	M6 x 1-6H	SPK-FG-S
DFC-100	500	50	110	1600	50,000	200	0.024	0.60	M6 x 1-6H	SPK-FG-S
DFC-200	1000	100	225	-	-	200	0.021	0.54	M6 x 1-6H	SPK-FG-M
DFC-500	2500	250	550	-	-	200	0.028	0.70	M10 x 1.5-5H	SPK-FG-L

NOTES

Load measurement accuracy is $\pm 0.1\%$ of load cell capacity. Display resolution is 10,000:1.

DFG - Basic Force Controller										
Model No.	Load Capacity					Safe Overload % Full Scale	Full Scale Deflection		Thread mm	Accessory Kit
	N	KGf	LBF	OZF	GF		in	mm		
DFG-10	50	5	10	160	5000	200	0.006	0.15	M6 x 1-6H	SPK-FG-S
DFG-20	100	10	20	320	10,000	200	0.008	0.20	M6 x 1-6H	SPK-FG-S
DFG-50	250	25	50	800	25,000	200	0.015	0.39	M6 x 1-6H	SPK-FG-S
DFG-100	500	50	110	1600	50,000	200	0.024	0.60	M6 x 1-6H	SPK-FG-S
DFG-200	1000	100	225	-	-	200	0.021	0.54	M6 x 1-6H	SPK-FG-M
DFG-500	2500	250	550	-	-	200	0.028	0.70	M10 x 1.5-5H	SPK-FG-L

NOTES

Load measurement accuracy is $\pm 0.2\%$ of load cell capacity. Display resolution is 5,000:1.



PRECISION MAKES THE DIFFERENCE

PURE PRECISION.

The combined powerful features of the Starrett MVR and AVR Vision Systems provide a multi-functional measurement and inspection system that will serve you for years to come.



Starrett®

(978) 249-3551 • starrett.com

Follow us!





MANUAL TEST STANDS

MANUAL FORCE TESTERS

MTL MANUAL TESTERS

The MTL Manual Testers are single column, manually-operated force testers. These testers operate with a quick-action lever in either tension or compression directions. Two models are available- the MTL-110 and MTL-330. Force measurement is performed using a Starrett DFC or DFG digital force gage.

MTL-110

The MTL-110 can measure force up to 110lbf (500N, 50kgf). This tester is ideal for component testing and its compact design fits small work spaces. The MTL-110 has a 6" (152mm) stroke. The tester's quick-action lever moves the rack and pinion crosshead 3" (76mm) per revolution. The lever may be positioned anywhere along the 20" (508mm) column, and with a 6" (152mm) throat, large samples can be accurately tested. Options include a digital scale for measuring deflection distance. The base adapter adjusts to accommodate different gage models.

MTL-330

The MTL-330 can measure force up to 330lbf (1500N, 150kgf). This tester can be used for tensile and compression testing applications, and is ideal for spring testing. Fit the MTL-330 with a Starrett digital force gage and optional digital scale to determine spring rates, initial tension and more. The MTL-330 can be easily mounted to your workbench for secure testing.

Like the MTL-110, the quick-action lever moves the rack and pinion crosshead 3" (76mm) per revolution. The lever may be positioned anywhere on the 30" (762mm) column, and with a 4" (102mm) throat, large samples can be accurately tested. Optional gage adapter kits are available for use with non-Starrett force gages.

The MTL may be equipped with optional legs so that you can test in a horizontal position.

FEATURES

- Two Capacities: 110lbf, 330lbf (500N, 1500N)
- Compact Design is Ideal for Lean Manufacturing Environments
- Lever-type, Quick-action Crosshead Movement
- Precision Rack and Pinion
- Excellent Position Resolution: Single Rotation for 3" (75mm)
- Adjustable Gage Mounting



MTL - Manual Force Tester, Lever Control														
Model No.	Load Capacity			Crosshead Travel		Resolution/Rotation		Throat		Weight		Vertical Test Space (max.)		Thread
	N	KGF	LBF	in	mm	in	mm	in	mm	lbs	kgs	in	mm	mm
MTL-110	500	50	110	6	152	3	76	4	102	18	8.2	9	230	M6, #10-32
MTL-330	1500	150	330	6	152	3	76	4	102	20	9.1	15	381	M10

MTH MANUAL TESTERS

The MTH Manual Tester is a single column, manually-operated force tester. The MTH has a load measurement capacity of 550lbf (2500N, 250kgf) and can be used for compression or tensile testing. The mechanical advantage afforded by the MTH-550's precision, high-resolution worm gear design lets you test effortlessly. One rotation of the hand wheel positions the crosshead 0.03" (0.75mm). Total stroke for the MTH-550 is 4" (102mm). Force measurement is performed using a Starrett digital force gage.

The MTH-550 is an ideal, affordable solution for spring testing. Fit the MTH-550 with a digital force gage and optional digital scale to determine spring rates, initial tension and more.

The hand wheel may be positioned anywhere along the 30" (762mm) column, and with a 4" (102mm) throat, large samples can be accurately tested. The base may be permanently affixed to your workbench. Optional gage adapter kits are available for use with non-Starrett force gages. Quick-change clevis adapters let you mount a large selection of Starrett testing fixtures.

FEATURES

- Tension or Compression Testing
- Excellent for Cost-Effective Spring Testing
- Effortless Crosshead Movement
- Precision Worm Gear Design
- Excellent Position Resolution: Single Rotation for 0.03" (0.75mm)
- 30" (762mm) Column Height, 15" (380mm) Working Area
- Adjustable Gage Mounting

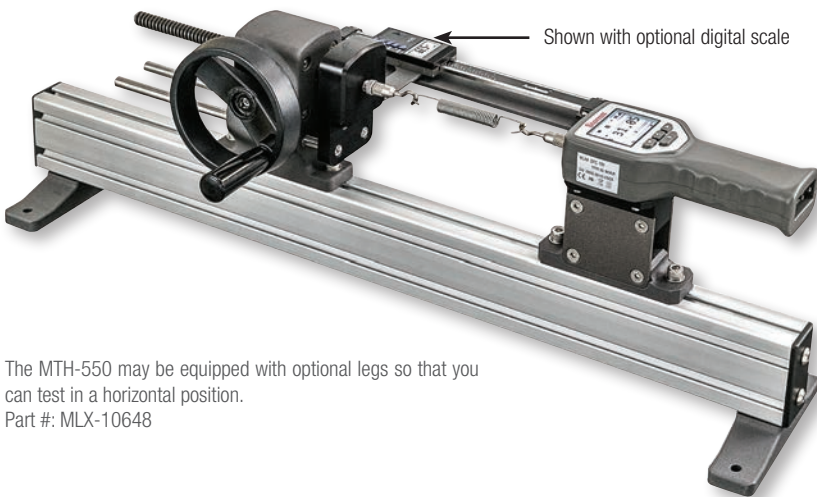

The MTH-550 may be equipped with optional legs so that you can test in a horizontal position.
Part #: MLX-10648

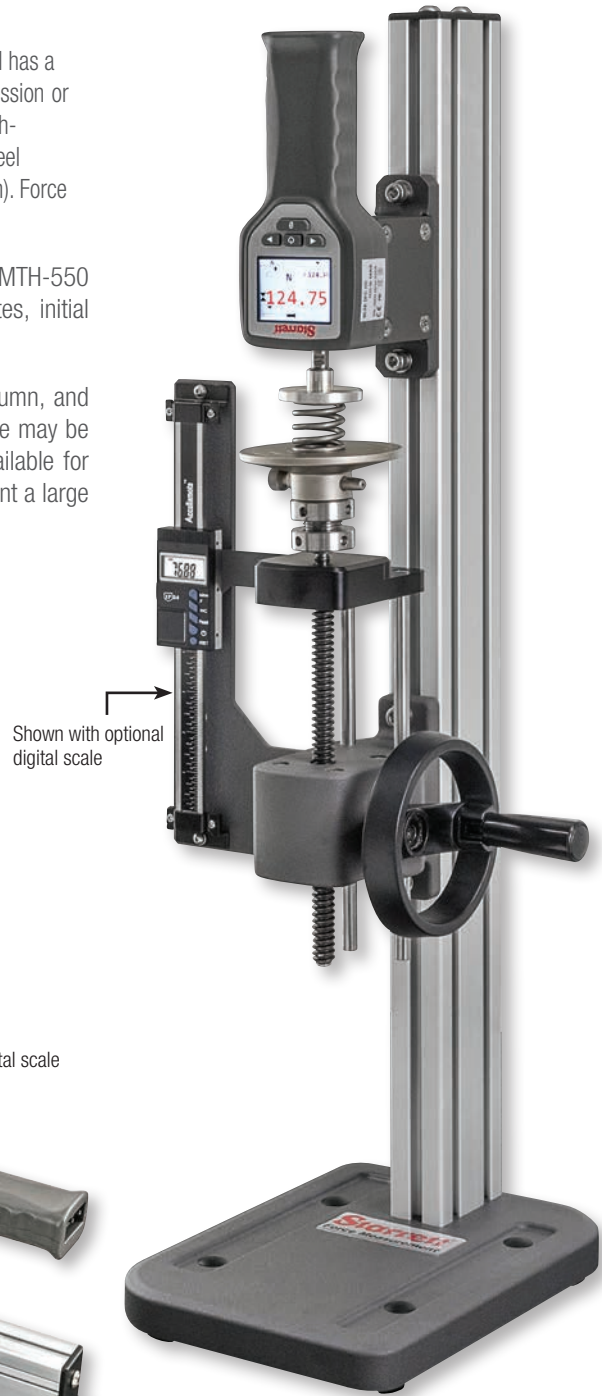

MTH - Manual Force Tester, Hand wheel Control														
Model No.	Load Capacity			Crosshead Travel		Resolution/Rotation		Throat		Weight		Vertical Test Space (max.)		Thread
	N	KGF	LBF	in	mm	in	mm	in	mm	lbs	kgs	in	mm	mm
MTH-550	2500	250	550	7.5	190	0.03	0.75	4	102	22	10	15	381	M10 x 1.5-5H



PRECISION MAKES THE DIFFERENCE

PURE PRECISION.

The combined powerful features of our metrology inspection and measurement systems will provide your test facility with a multi-functional measurement and inspection system that will serve you for years to come.



Starrett®

(978) 249-3551 • starrett.com

Follow us!





MOTORIZED TEST STANDS

FLEXIBLE SYSTEM DESIGN

Starrett offers a wide range of motorized test frames and software options. These flexible solutions help us match test frames and software capabilities with customer requirements. Systems are comprised of a test frame, software, load cells, grips, and accessories.

FRAMES

FMM Series

110, 330, 550lbf

FMS Series

1kN, 2.5kN, 5kN

FMD Series

10kN, 30kN, 50kN

MATERIAL MEASUREMENT

MMS Series

1kN, 2.5kN, 5kN

MMD Series

10kN, 30kN, 50kN

SOFTWARE

DFC

L1

L2Plus

L3

LOAD CELL SENSORS

BLC Series

FLC Series

MLC Series

Starrett can supply a wide assortment of testing fixtures that comply with international testing standards from ASTM, ISO, DIN, TAPPI and more. We can also supply custom test fixtures for difficult sample shapes.

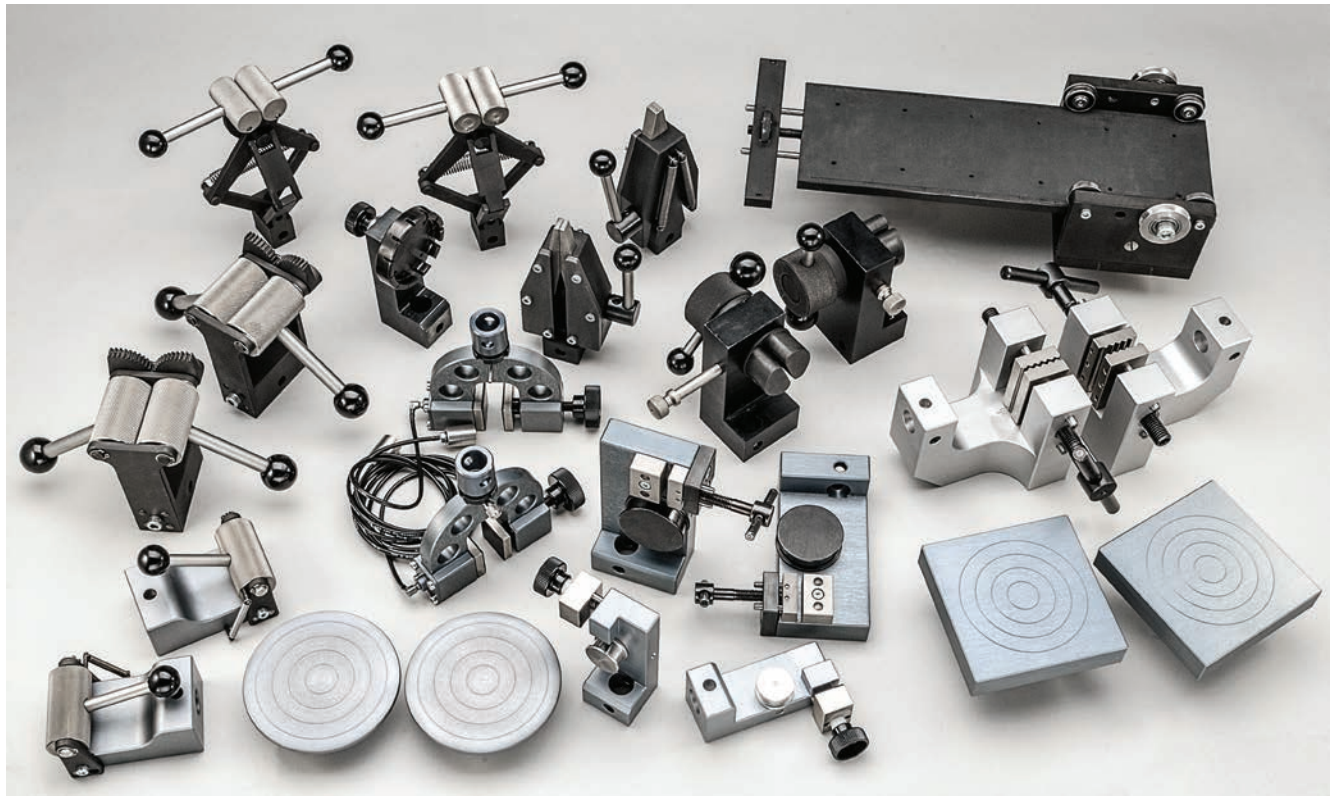

FMM FRAME OVERVIEW

FMM digital force testers are compact and ideal for high volume, lean manufacturing production. FMM Digital Force Testers may be used manually, with a DFG or DFC digital force gage, or any of the Lx software versions, L1, L2Plus and L3.

FMM testers are available in three capacities: 110lbf (500N), 330lbf (1500N) and 550lbf (2500N). Two travel lengths are available for all capacities: standard travel at 20" (508mm) and extended travel at 30" (762mm). Crosshead speeds are controlled locally and can be set from 0.002 to 40 inch/min (0.05 to 1016mm/min). Quiet even when operating at full speed. Easily upgrade from force gage control to computer based operating using Lx software.



FMS/MMS FRAME OVERVIEW

Accurate and easy to use. When you need an easy-to-use measurement system for accurately and precisely determining simple load, distance, and break applications or more complex material testing applications like Young's Modulus, tensile strength, stress, or strain the FMS and MMS series test frames are the answer. Available in 1000N (225lbf), 2500N (562lbf), and 5000N (1124lbf) capacities.

The FMS series test frame supports L2Plus, and L3 versions of the Lx software. The MMS is the material testing version with higher accuracy encoders and extensometer support to work in conjunction with the Starrett L3 software. It's the accuracy, repeatability, and simplicity you expect from L.S. Starrett.

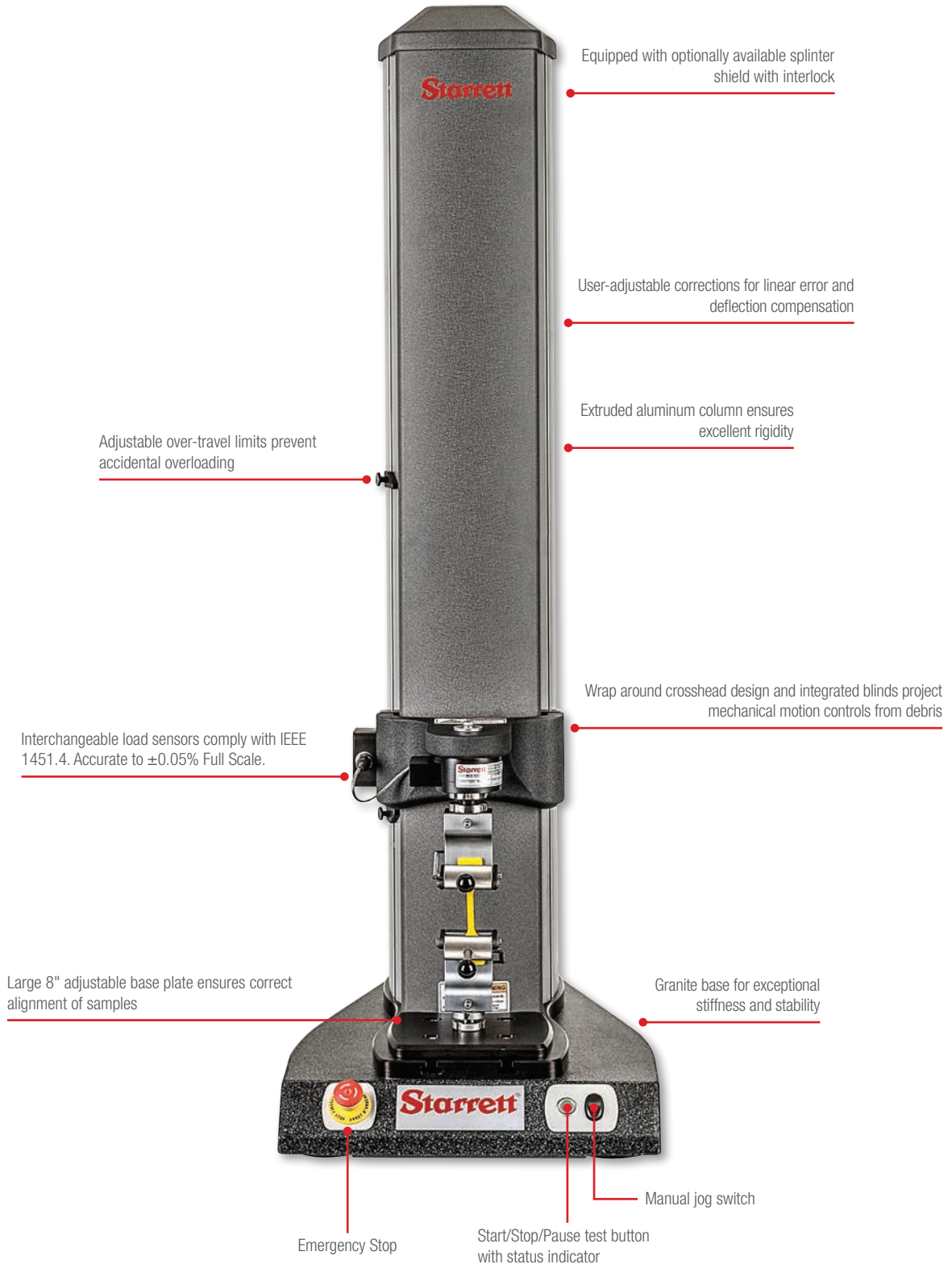

FMD/MMD FRAME OVERVIEW

The FMD and MMD series test frames are suited for simple force and distance applications and more complex material testing applications. The FMD series test frame supports L2Plus, and L3 versions of the Lx software, pair it with the software version that best suits your testing needs. Available in 10kN (2,250lbf), 30kN (6,750lbf), or 50kN (11,250lbf) capacities.

MMD frames include extensometer support to work in conjunction with the L3 material testing software. The twin post design features a large 16.7 in (424mm) testing area between the columns and space on the granite base for sample preparation or staging.

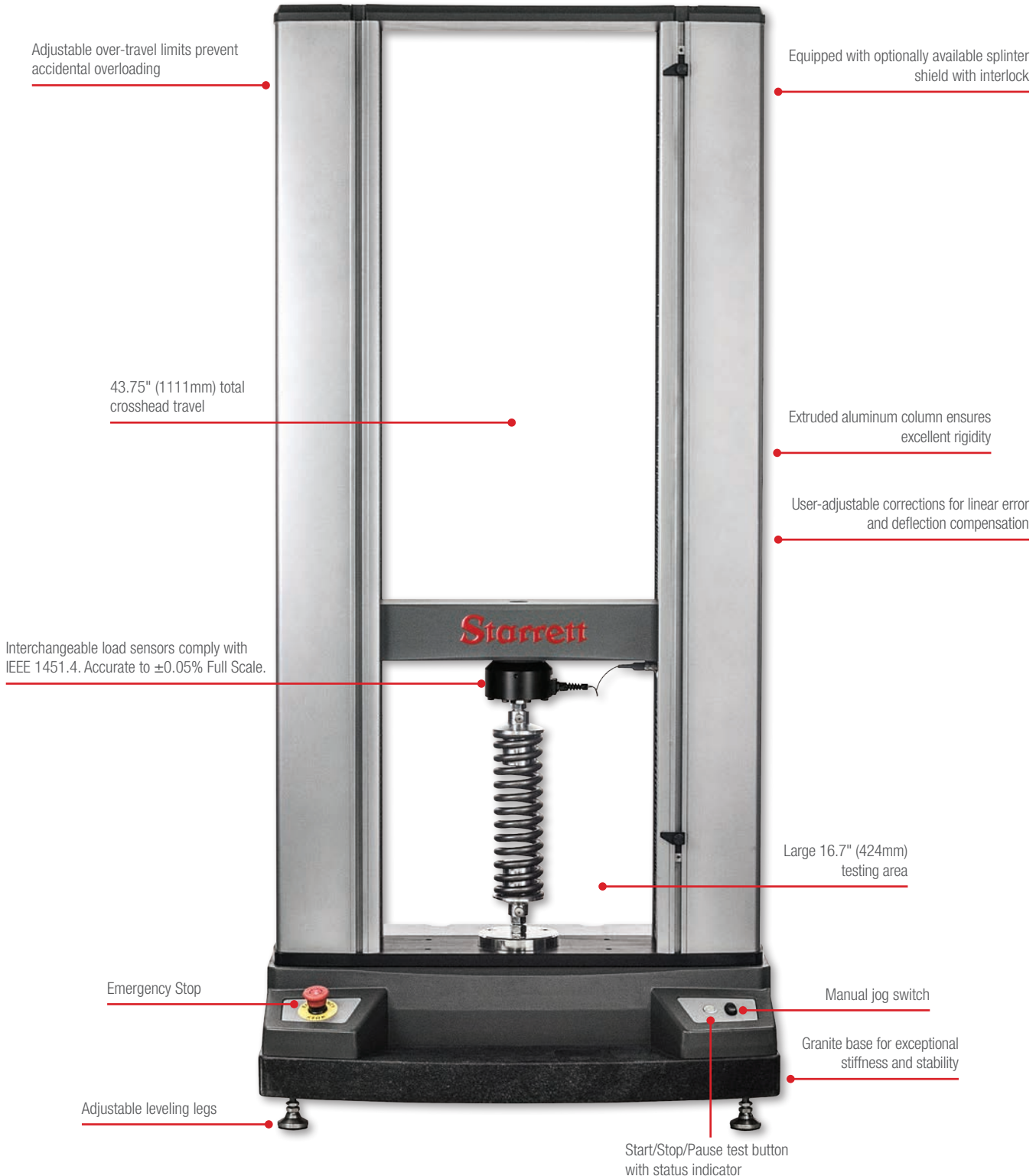

TEST FRAMES

FMM SERIES ECONOMY DIGITAL FORCE TESTERS

FMM Series Test Frames										
Model		Short Travel			Standard Travel			Extended Travel		
		FMM-110S	FMM-330S	FMM-550S	FMM-110	FMM-330	FMM-550	FMM-110X	FMM-330X	FMM-550X
Load Capacity	N	500	1500	2500	500	1500	2500	500	1500	2500
	kgf	50	150	250	50	150	250	50	150	250
	lbf	110	330	550	110	330	550	110	330	550
Minimum Speed	mm/min	0.05								
	in/min	0.002"								
Maximum Speed	mm/min	1000								
	in/min	40								
Max Distance Resolution ¹	mm	0.02								
	in	0.001"								
Vertical Test Space ²	mm	400	400	400	559	559	559	813	813	813
	in	15.6	15.6	15.6	22	22	22	32	32	32
Total Crosshead Travel	mm	305	305	305	508	508	508	762	762	762
	in	12	12	12	20	20	20	30	30	30
Throat	mm	100								
	in	3.9								
Axial Frame Stiffness	kN/mm	2.5	2.6	2.7	2.5	3.1	3.1	2.2	2.5	2.5
	lbf/in	14,200	14,800	15,400	14,200	17,700	17,700	12,500	14,200	14,200
Accuracy Load Measurement		Load Cell Dependent								
Accuracy Position Measurement		±0.001in (20µm) or 0.1% of travel (whichever is greater)								
Accuracy Strain Measurement		N/A								
Accuracy Crosshead Speed		±0.1% of set speed								
Compatible Software		L1, L2Plus, L3, and DFC Control								
Data Sampling	Hz									
Digital I/O		0 - 24Vdc (independent, configurable)								
Extensometer Connections		N/A	N/A	N/A	N/A	N/A	N/A	N/A	N/A	N/A
Analog Inputs		N/A	N/A	N/A	N/A	N/A	N/A	N/A	N/A	N/A
Electrical Phase		1								
Power Requirements		100, 120, 220, 230, 240VAC 10%; 47-63Hz Self-identifying								
Operating Temperature	°C	+5° to +43°C								
	°F	+40° to +110°F								
Storage Temperature	°C	+5° to +43°C								
	°F	+40° to +110°F								
Humidity		+10% to +90%, non-condensing								
Base Plate Threads	mm	#10-32, 5/16-18, 1/4-28, 1/2-20 (optional)								
	in	M4 x 0.7, M6 x 1, M10 x 1.5, M12 x 1.75 (standard)								
Total Height	mm	733			940			1194		
	in	28.9			37			47		
Total Width	mm	292								
	in	11.5								
Total Depth	mm	419								
	in	16.5								
Weight	kg	31.8			36.3			43		
	lb	70			80			95		

1. Total vertical space is the distance from the top surface of the base plate to the bottom surface of the crosshead, excludes load cell and fixtures
 2. Resolution configurable in L3, L2Plus, and L1, fixed in DFC control

TEST FRAMES

FMS AND MMS SERIES TEST FRAMES

Force and Material Test Frames										
Model		FMS-1000	FMS-2500	FMS-5000	MMS-1000	MMS-2500	MMS-5000	FMD-10K/ MMD-10K	FMD-30K/ MMD-30K	FMD-50K/ MMD-50K
Load Capacity	N	1000	2500	5000	1000	2500	5000	10,000	30,000	50,000
	kgf	100	250	500	100	250	500	1000	3000	5000
	lbf	225	562	1124	225	562	1124	2250	6750	11,250
Minimum Speed	mm/min	0.05	0.05	0.05	0.001	0.001	0.001	0.001	0.001	0.001
	in/min	0.002	0.002	0.002	0.00004	0.00004	0.00004	0.00004	0.00004	0.00004
Maximum Speed	mm/min	1525	1525	1525	1525	1525	1525	1525	1525	752
	in/min	60	60	60	60	60	60	60	60	30
Max Distance Resolution ¹	mm	0.02	0.02	0.02	0.002	0.002	0.002	0.002	0.002	0.002
	in	0.001	0.001	0.001	0.0001	0.0001	0.0001	0.0001	0.0001	0.0001
Vertical Test Space ²	mm	953	1257	1257	953	1257	1257	1270	1245	1220
	in	37.5	49.5	49.5	37.5	49.5	49.5	50	49	48
Total Crosshead Travel	mm	762	1016	1016	762	1016	1016	1162	1137	1111
	in	30	40	40	30	40	40	45.75	44.75	43.75
Throat	mm	100	100	100	100	100	100	424	424	424
	in	4	4	4	4	4	4	16.7	16.7	16.7
Axial Frame Stiffness	kN/mm	4.3	4.3	8.52	4.3	4.3	8.52	61.4	96.8	115.1
	lbf/in	24,700	24,700	48,500	24,700	24,700	48,500	350,800	553,000	657,500
Accuracy Load Measurement		Load Cell Dependent								
Accuracy Position Measurement		±0.0004in (10µm) or 0.1% of travel (whichever is greater)			±0.0002in (5µm) or 0.1% of travel (whichever is greater)					
Accuracy Strain Measurement		N/A	N/A	N/A	±0.5% of reading down to 1/50 of full scale with ASTM E83 class B or ISO 9513 class 0.5 extensometer					
Accuracy Crosshead Speed		±0.1% of set speed								
Compatible Software		L2Plus and L3								
Data Sampling	Hz	5 to 1000			1 to 2000					
Digital I/O		8 channels @ 1-5V								
Extensometer Connections		N/A	N/A	N/A	2 channels for 0-10V extensometers					
Analog Inputs		N/A	N/A	N/A	1 channel @ ±10V					
Electrical Phase		1								
Power Requirements		100, 120, 220, 230, 240VAC 10%; 47-63Hz Self-identifying						100, 120, 220, 230, 240Vac 10%	Single Phase Voltage (Vac) ±10% 220-240V	
Operating Temperature	°C	+10° to +38°C								
	°F	+50° to 100°F								
Storage Temperature	°C	-40° to +66°C								
	°F	-40° to 150°F								
Humidity		+10% to +90%, non-condensing								
Base Plate Threads	mm	M6 x 1	M12 x 1.75	M12 x 1.75	M6 x 1	M12 x 1.75	M12 x 1.75	M16 x 2	M16 x 2	M16 x 2
Total Height	mm	1218	1573	1573	1218	1573	1573	1685	1711	1711
	in	47.9	61.9	61.9	47.9	61.9	61.9	66.4	67.4	67.4
Total Width	mm	381	381	381	381	381	381	787	787	787
	in	15	15	15	15	15	15	31	31	31
Total Depth	mm	514	514	514	514	514	514	724	724	724
	in	20.3	20.3	20.3	20.3	20.3	20.3	28.5	28.5	28.5
Weight	kg	77	88	88	77	88	88	136	192	225
	lb	170	195	195	170	195	195	300	425	500

1. Total vertical space is the distance from the top surface of the base plate to the bottom surface of the crosshead, excludes load cell and fixtures

2. Resolution configurable in L3, L2Plus, and L1, fixed in DFC control

TEST FRAMES

DIMENSIONS

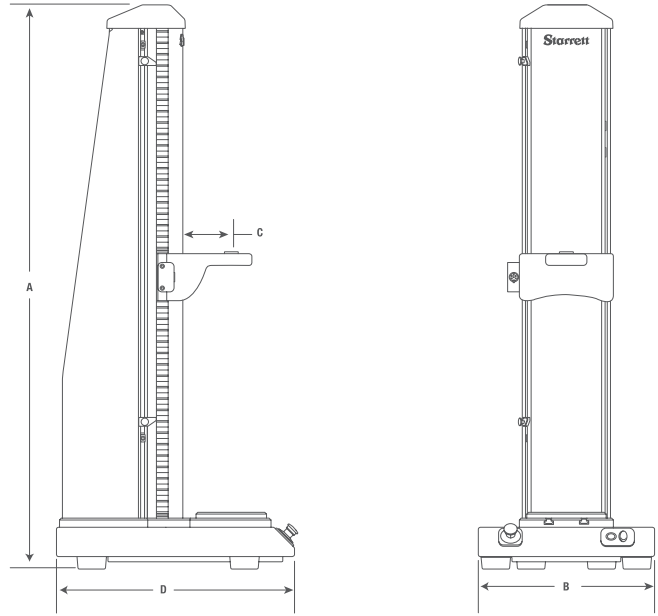

Dimensions				
Single Column Test Frames	A	B	C	D
MMS/FMS-1000 Test Frame	47.9 in 1218mm	15.0 in 381mm	4.1 in 105mm	20.3 in 514mm
MMS/FMS-2500 Test Frame	61.9 in 1573mm	15.0 in 381mm	4.1 in 105mm	20.3 in 514mm
MMS/FMS-5000 Test Frame	61.9 in 1573mm	15.0 in 381mm	4.1 in 105mm	20.3 in 514mm

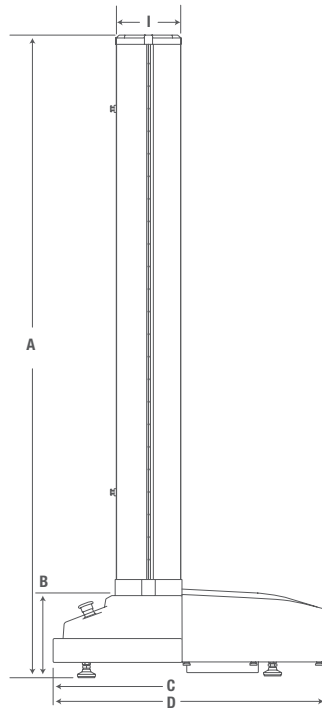
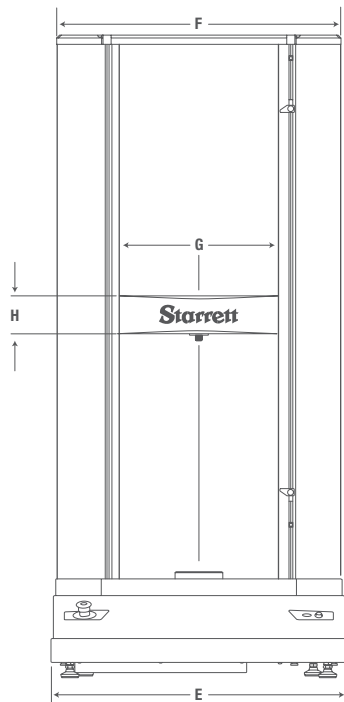

Dimensions									
Dual Column Test Frames	A	B	C	D	E	F	G	H	I
MMD/FMD-10K Test Frame	66.4 in 1685mm	9.4 in 238mm	10.0 in 254mm	28.5 in 724mm	31.0 in 787mm	29.7 in 754mm	16.7 in 424mm	3.0 in 76mm	6.7 in 170mm
MMD/FMD-30K Test Frame	67.4 in 1711mm	10.4 in 263mm	10.0 in 254mm	28.5 in 724mm	31.0 in 787mm	29.7 in 754mm	16.7 in 424mm	4.0 in 102mm	6.7 in 170mm
MMD/FMD-50K Test Frame	67.4 in 1711mm	10.4 in 263mm	10.0 in 254mm	28.5 in 724mm	31.0 in 787mm	29.7 in 754mm	16.7 in 424mm	5.0 in 127mm	6.7 in 170mm

DIMENSIONS

STANDARD TRAVEL

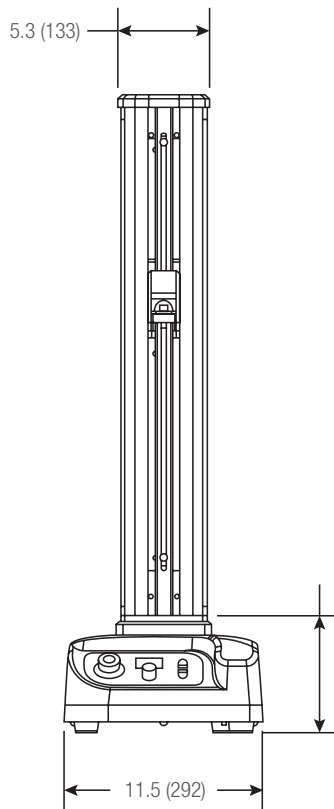
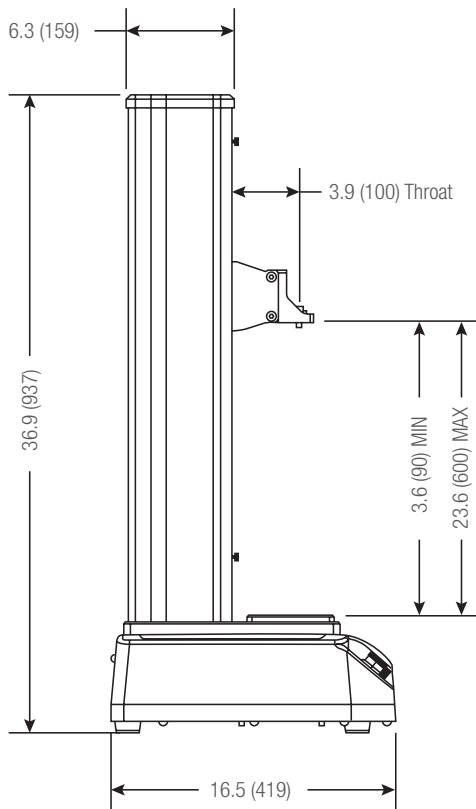

EXTENDED TRAVEL

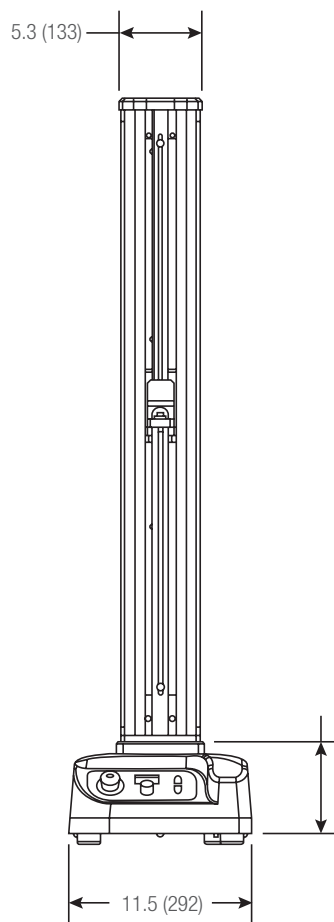
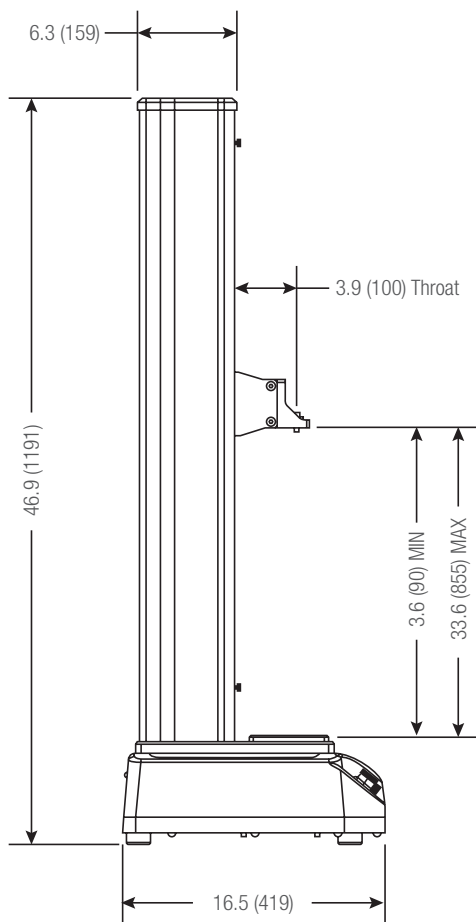

SHORT TRAVEL

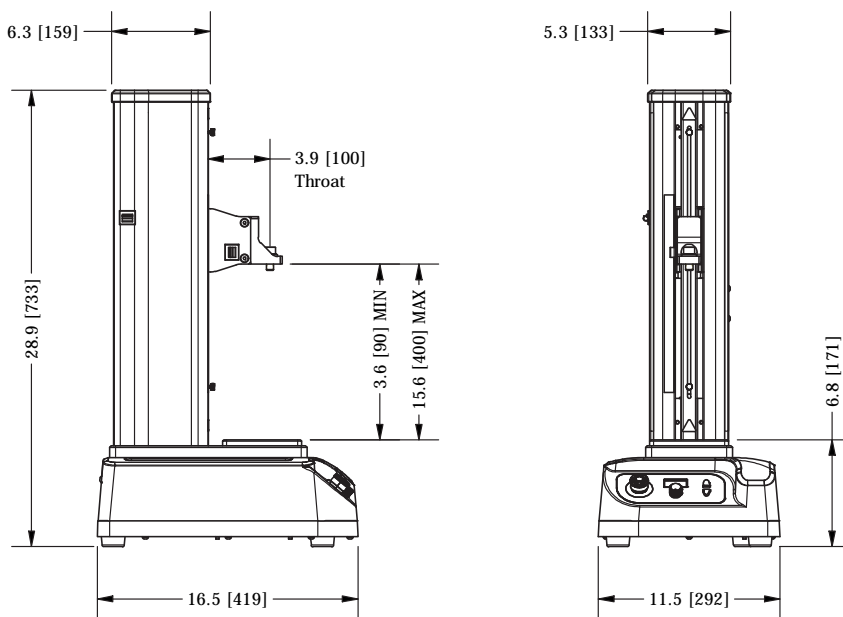

The L1-Base-M is included standard on all FMM motorized test stands. Access the M4x0.7, M6x1, M10x1.5, or M12x1.75 threads by rotating the baseplate 90 degrees.

The L1-Base-US is an optional accessory. Access the #10-32, 1/4-23, 5/16-18, or 1/2-20 threads by rotating the baseplate 90 degrees.

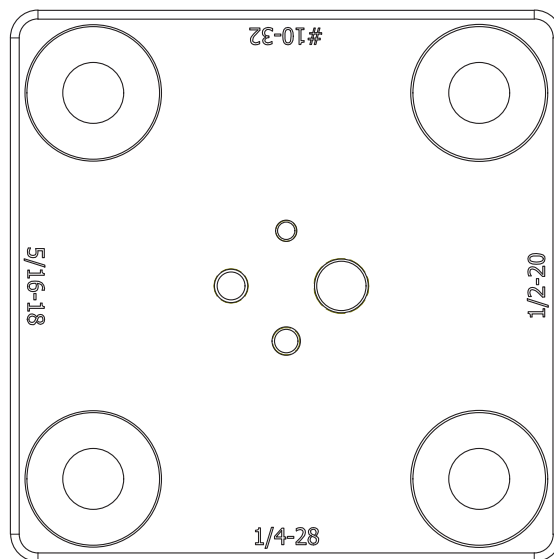
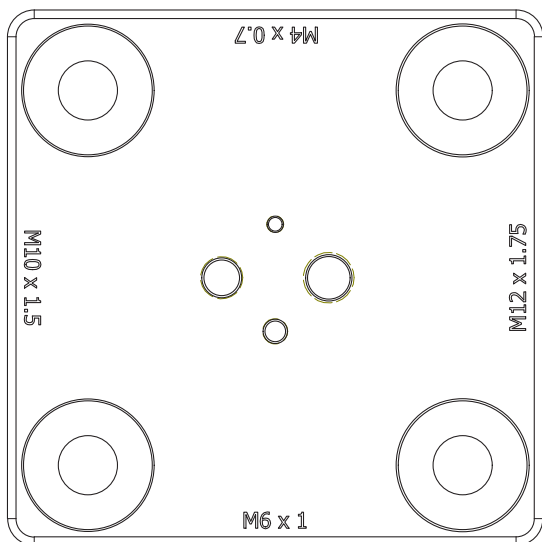



SOFTWARE

CREATE. TEST. ANALYZE. REPORT.



L3 SOFTWARE

L3 Systems are optimized for users involved with material testing and characterization- the research engineer, the design engineer, the quality control technician, the test technician and others.

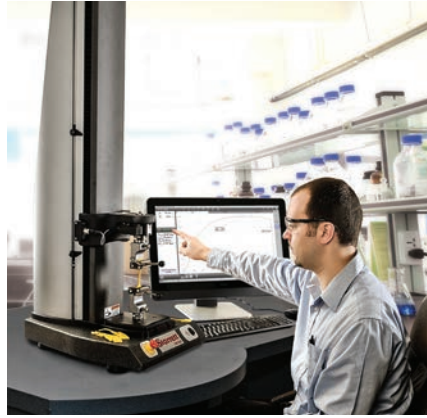

L2 PLUS SOFTWARE

L2 Plus Systems provide engineering and quality personnel with an easy-to-use, yet comprehensive solution for complex force analysis and measurement.



L1 SOFTWARE

L1 Systems are great for quality control and incoming inspection. They are engineered to meet the requirements for fast, efficient, high-volume production testing. Combining functionality with affordability.



DFC CONTROL

The DFC control option utilizes the DFC hand held force gages universal interface for basic load, distance and break testing. A great entry level economic solution.

Lx Software Product Comparisons and Capabilities				
	L3	L2 Plus	L1	DFC
Target Applications				
Use for Stress, Strain and Material Testing applications	○			
Use for Advanced Load, Distance and Force Analysis applications	○	○		
Use for Basic Load, Distance and Force Measurement applications	○	○	○	
Use for Advanced Extension and Compression Spring applications	○	○		
Use for Basic Extension and Compression Spring applications			○	
User Interface				
All-In-On Computer Workstation, Windows® OS	○	○		
Tablet Computer, Windows® OS			○	
Force Gage				○
Software Applications				
Test Builder	○	○		
Force Quick Test Templates			○	
Spring Quick Test Templates			○	
Formula Builder	○	⊕		
Automation Builder	⊕	⊕		
Measurement Methodology				
Measure results using the graph	○	○		
Measure results using a List of Value menu	○	○		
Create Test Setups using Graphical Test Methods (No programming)	○	○		
Create Test Setups using Quick-Test Templates			○	
Test Methods				
Tensile Testing, Load, Distance, Break, Rate	○	○	○	○
Compression Testing, Load, Distance, Break, Rate	○	○	○	○
Hold Testing, Load, Distance for Duration or Event	○	○	○	
Cyclic Testing for Duration, Count, Loop or Event	○	○	○	
Shear Testing	○	○		
Flexural Testing	○	○		
Peel Testing	○	○		
Coefficient of Friction Testing	○	○		
Spring Testing	○	○	○	
Measurement Capabilities				
Measure Stress, Strain, Elongation, Strengths	○			
Measure Offset Yield	○			
Measure Modulus (Elastic, Chord, Tangent)	○			
Measure Strain and Elongation using Extensometer(s) (requires MMx test frames)	○			
Measure Energy, Work, Resilience	○	○		
Create Mathematical Expressions using Algebraic, Trigonometric and Logarithmic functions	○	▷		
Create Basic Expressions using Add, Subtract, Multiple and Divide	○	▷		
Use Digital I/O	▷	▷		
Use Analog I/O (requires MMx test frames)	▷	▷		
Use Command and Conditional Logic	▷	▷		
Measure Load, Distance, Time	○	○	○	○
Measure Minimum and Maximum	○	○	○	
Measure Averages	○	○		
Measure Slopes and Intersections	○	○		
Measure Peaks, Valleys, Counts, Averages	○	○		
Measure Break, Rupture	○	○	○	○
Measure Delta between results within a test	○	○		
Measure results within multiple test runs simultaneously (multiview)	○	○		
Measure Spring Rate, Spring Constant, Free Length	○	○	○	
Reporting and Exporting Data				
Print using standard reports, graph, batch, tolerance, statistics	○	○	○	
Export results/data in .csv for custom reporting	○	○	○	
Export results/data in .csv for integration with SPC software	○	○	○	
Include tolerances on any result	○	○	○	○

- = Standard
- ⊕ = Optional
- = Requires Test Builder application
- ▷ = Requires Automation Builder application

L3 SOFTWARE

Starrett L3 systems represent a new and easier solution for creating a test; performing a test; analyzing your test results; and managing test data.

L3 systems meet the requirements of today's research scientist, design engineer, quality manager or technician responsible for material characterization, verification and validation.

Unlike traditional material testing systems that involve programming and having to know exactly what measurements are required before the test, L3 systems employ a simple methodology. You create your test method. Your test method creates your graph. And then you measure on the graph using a set of analysis tools.

You can measure any point and any segment anywhere along the graph. Analyze using stress, strain, load, distance, and time. Your measurements are displayed on your graph and shown in data tables with statistics and tolerances.

FEATURES

- Measure stress, strain, load, elongation, extension, and time results using tension, compression, flexural, cyclic, shear, and friction applications
- Create test setups using internationally accepted testing standards from ASTM, ISO, DIN, TAPPI and more, or create your own custom test methods
- Measure and calculate results graphically:
 - Points
 - Modulus, Slopes and Intercepts
 - Offset Yield
 - Min/Max/Avg
 - Breaks (Rate, %Drop)
 - Peaks and Valleys
 - Deltas
 - Rates
 - Hysteresis
 - Work/Energy
 - and more
- Options for digital and analog I/O and Control Logic

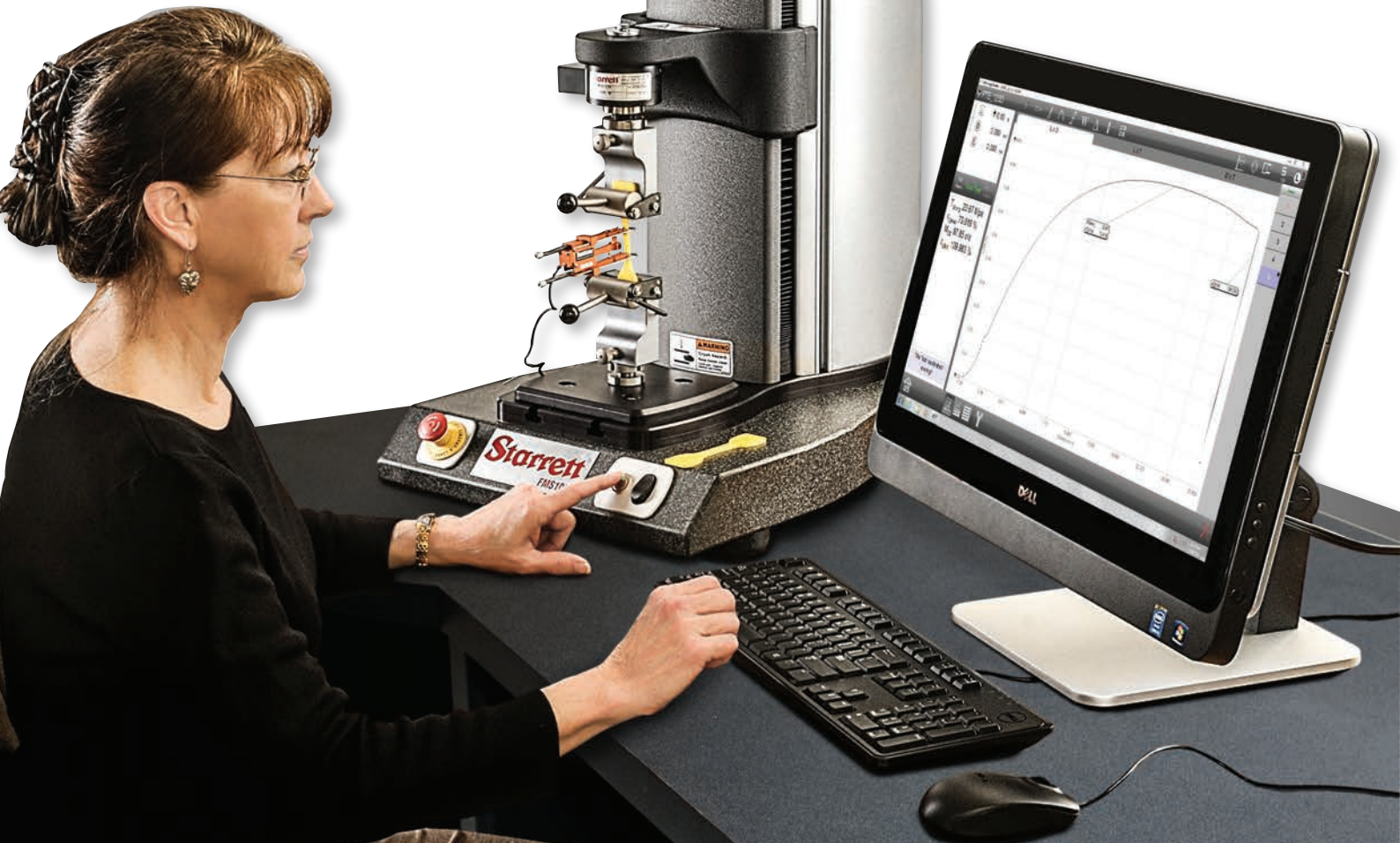

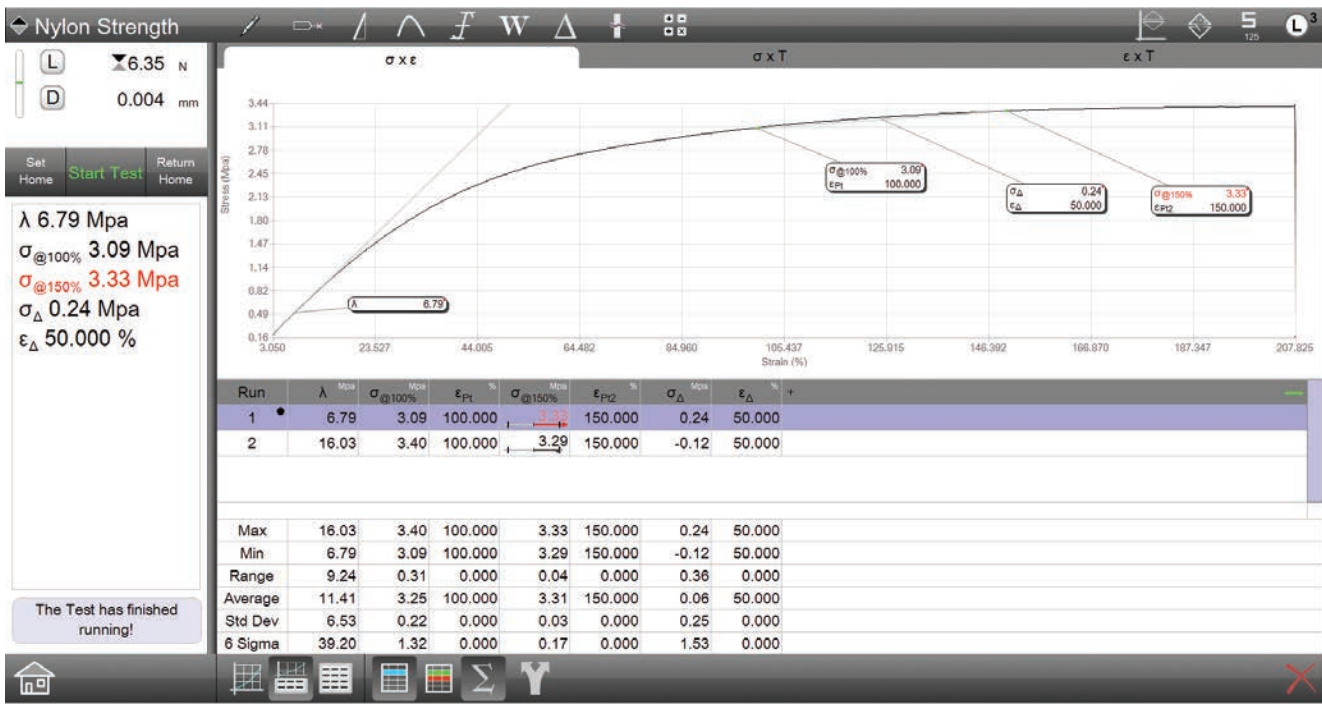

Measure results using SI or Imperial units of measure. Display results in Engineering Notation if needed. Specify resolutions for any unit type.

(Above) Out-of-tolerance results are displayed in red, including a tendency bargraph in the data table.

(Below) The Tolerance view provides more detailed information as to "why" the result is displayed in red.

View results on any of these graph formats: Stress vs. Strain, Stress vs. Time, Strain vs. Time, Load vs. Displacement, Load vs. Time, Displacement vs. Time. Display full graphs or split graphs with the data table showing statistics and tolerance values.

Statistics can be displayed and your raw data and results can be exported automatically using the Share function.

The operator can add comments about each test run, or use the Extra Coefficients function to display additional information for reporting. Standard reports are included, or export as a .csv file for use with Microsoft® Excel®, Word®, Access or your 3rd-party SPC application.

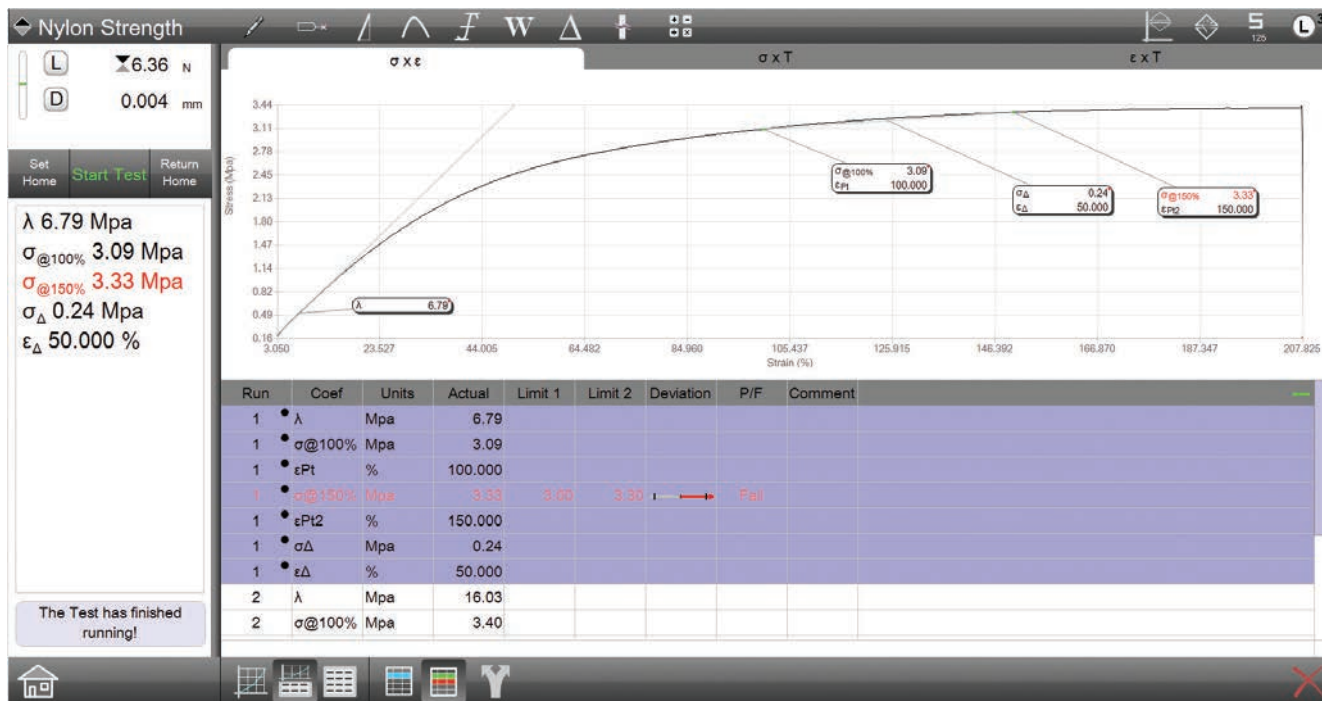

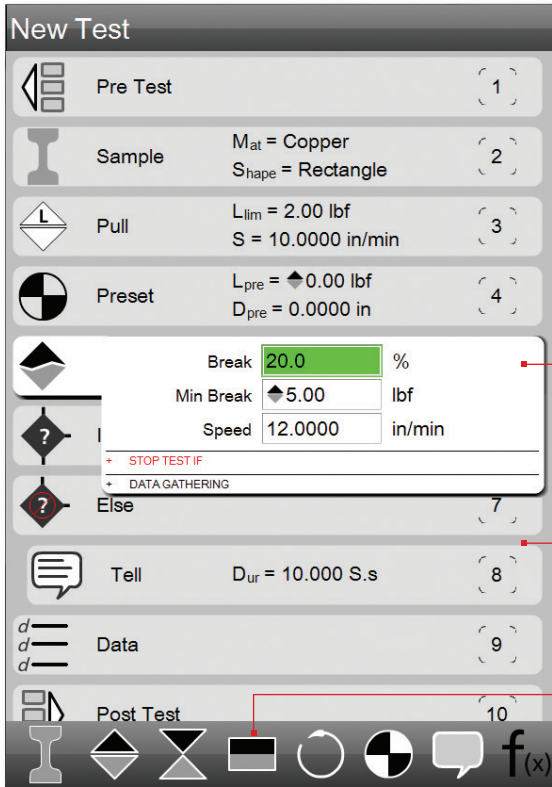

Construct simple and complex multi-step test setups. Create your test method to an accepted standard or to your specific testing needs.

Create your test method and then email to other locations so that your testing is always performed in the exact same manner with the same measurements and results.

Tensile and Compression steps are used to perform "go to moves". Go to a Limit or Break at a velocity or load rate. You can choose exceptions for any move and decide whether to collect data during the move.

Shown is an operator prompt based on a conditional branching state. If the measured result is "out-of-tolerance", a message is displayed alerting the operator. If the result is within the tolerance range, no message is displayed.

Hold steps are used for creep and relaxation testing. You can hold at a limit for a specified duration up to 24 hours, if necessary.

Cycle based on any of your steps in your test method. You may cycle up to 1000 times or for a duration of up to 24 hours at a sampling rate of 1Hz. Each test may have a maximum of 100,000 data points.

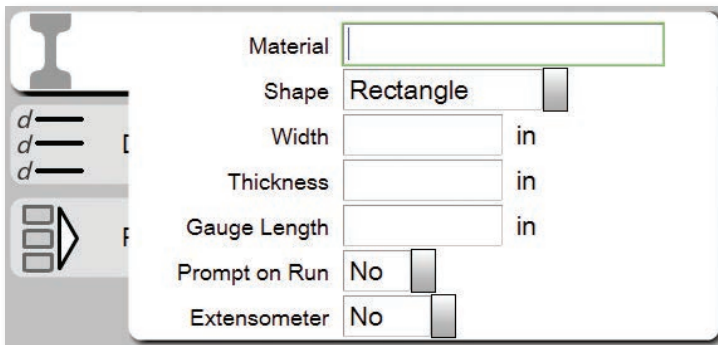

The Sample Definition step lets you name your material, specify the shape and its dimensions. You can enter dimensions digitally using a Starrett micrometer, or caliper.

Shown is the setup dialog for the optional I/O step. It allows you to control and activate external devices such as annunciators through the test frame's digital or analog I/O channels.

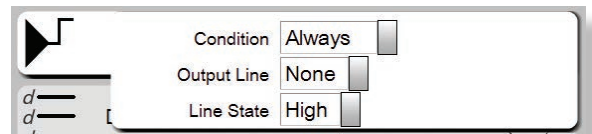

Shown are the various test setup step types, including specialized steps available using the optional Automation Builder.

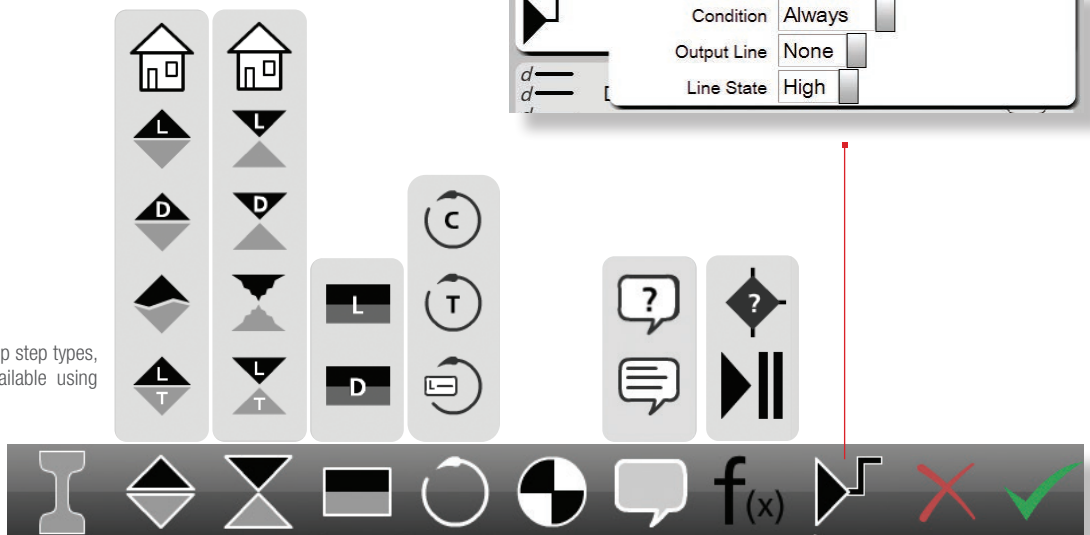

The Slope tool is used to find modulus. Multiple methods are available including automatic, chord, tangent, and best fit.

The Delta tool measures the differences between results. You can find creep by simply choosing this tool and the two points you want to compare.

Use the Annotation tool to add notes to any graph view.

Use the Min/Max/Avg tool to find maximum and minimum values. It can also be used to calculate averages of all data between a segment you specify.

You can compare multiple graphs of your test runs and measure delta and variances between tests at precise points. Ideal for benchmark analysis.



Use the Offset Yield Point tool to measure any data point on any of the three graph views. The point may be implicit or may be derived based on another result. For example, you can find the point at 100mS before the point at 100% strain.

Use the Work tool to determine the energy or resilience from your stress-strain graph.

Use the Formula Builder to create custom expressions and derived results using algebraic, trigonometric and logarithms.

The Peak/Valley tool is ideal for peel and coefficient of friction testing. Measure the maximum, minimum, average and counts of peaks and valleys.

Find break results based on a percentage drop or based on a load rate decrease.

The Offset Yield Point tool is used to measure the yield strength at a 2% strain offset. Shown is modulus at 100% and 150% and the delta between these two measurements.

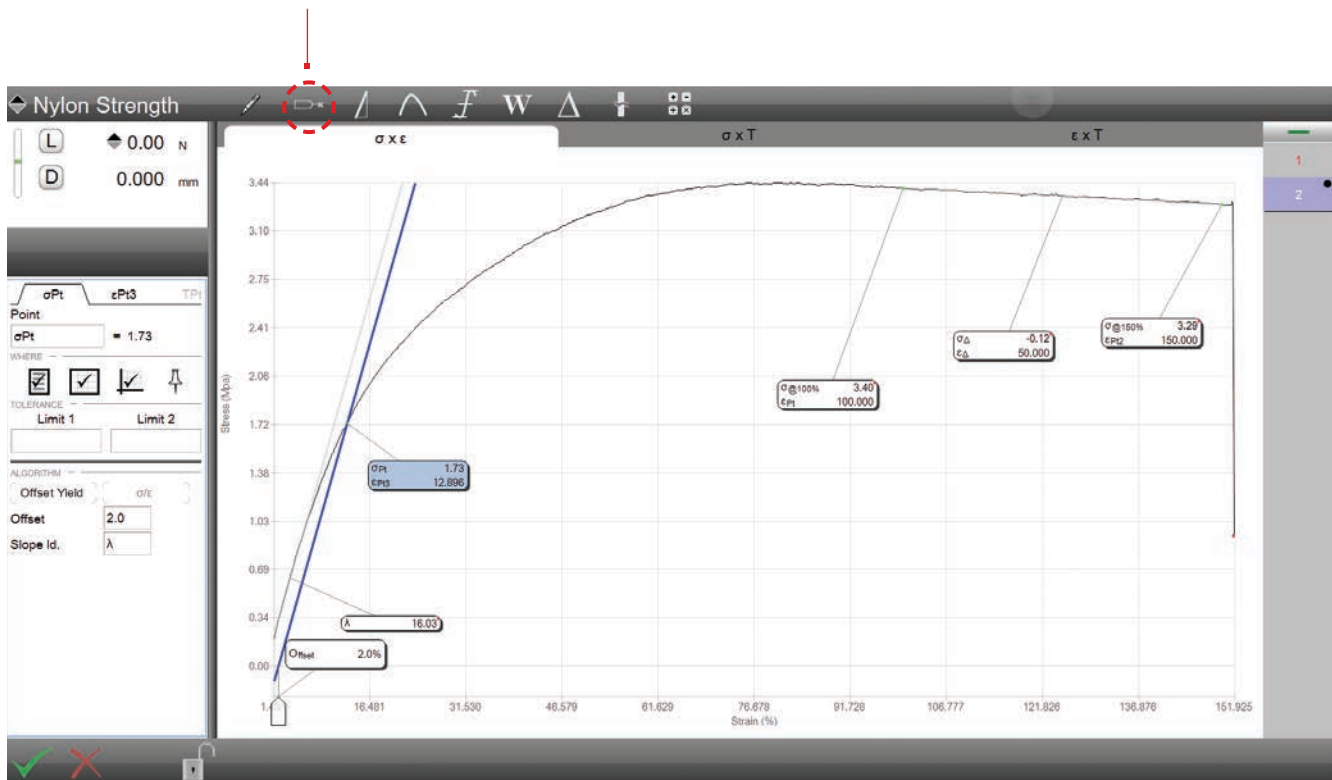

L2PLUS SOFTWARE

SOFTWARE

Designed for advanced force measurement and analysis, L2 Plus Systems are optimized for quality and engineering personnel. Test setup is intuitive, efficient and non-compromising.

With L2 Plus systems you not only find the measurement, but you have the information that shows you "why, when and where" the measurement occurs.

Like our L3 systems, L2 Plus measurements and analysis are performed graphically using our Windows®-based, all-in-one computer workstation. Create high resolution graphs based on load, distance, height and time. Then measure any point or segment on your graph using a set of analysis tools.

FEATURES

- Ideal for tension, compression, rate control, flexural, cyclic, shear, and friction applications
- Measure and calculate results graphically:
 - Points
 - Slopes and Intercepts
 - Min/Max/Avg
 - Breaks
 - Peaks & Valleys
 - Deltas
 - Rates
 - Work/Energy
- Create test setups using internationally accepted testing standards from ASTM, ISO, DIN, TAPPI and more, or create your own custom test methods
- Options for digital and analog I/O and Control Logic
- Options for arithmetic, trigonometric and logarithmic calculations
- Use bar code scanning to access test setups

Perform advanced testing methods such as load rate control. Set a target limit then pull/push at a rate using load per time velocity.





Specific algorithms for peak & valley measurements are supported: find peak/valley, find maximum/minimum peak/valley, find averages for peaks/valleys.

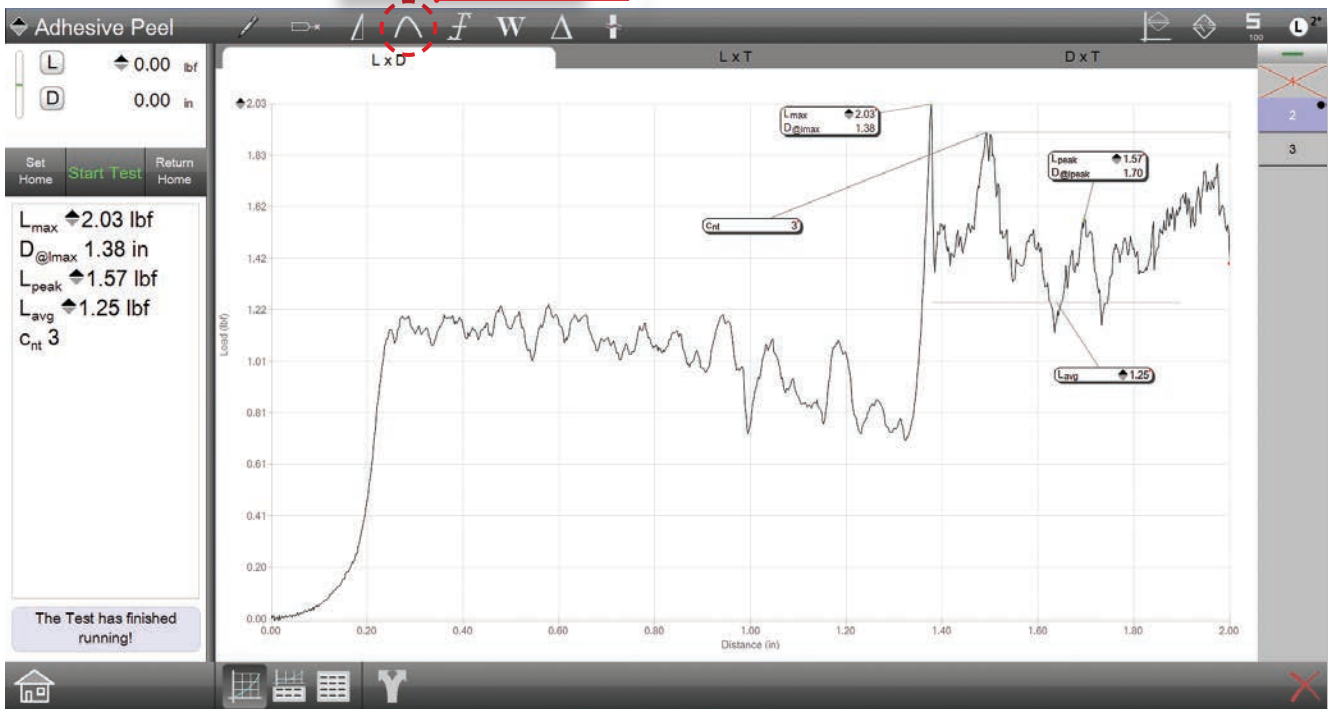

Your results can be displayed in markers on your graph, in data tables, or in combinations. Graph types are: Load vs. Distance, Load vs. Time, and Distance vs. Time. Markers can display the load, distance and time to a specific point on the graph.

(Above) Use the Peak/Valley tool to locate the peaks for the entire test duration or for a defined segment within the test, per ASTM F88. Qualify your peaks and valleys using the sensitivity adjustment. Measure average, counts, maximum, minimum and more.

(Below) The load average is calculated for qualified peak values using a load sensitivity of 25%. Adjust for sensitivity using the data definition menu or by using the sensitivity adjustment bar on the y-axis. In this example, the load average is specified at a segment starting at the maximum load point (Lmax).

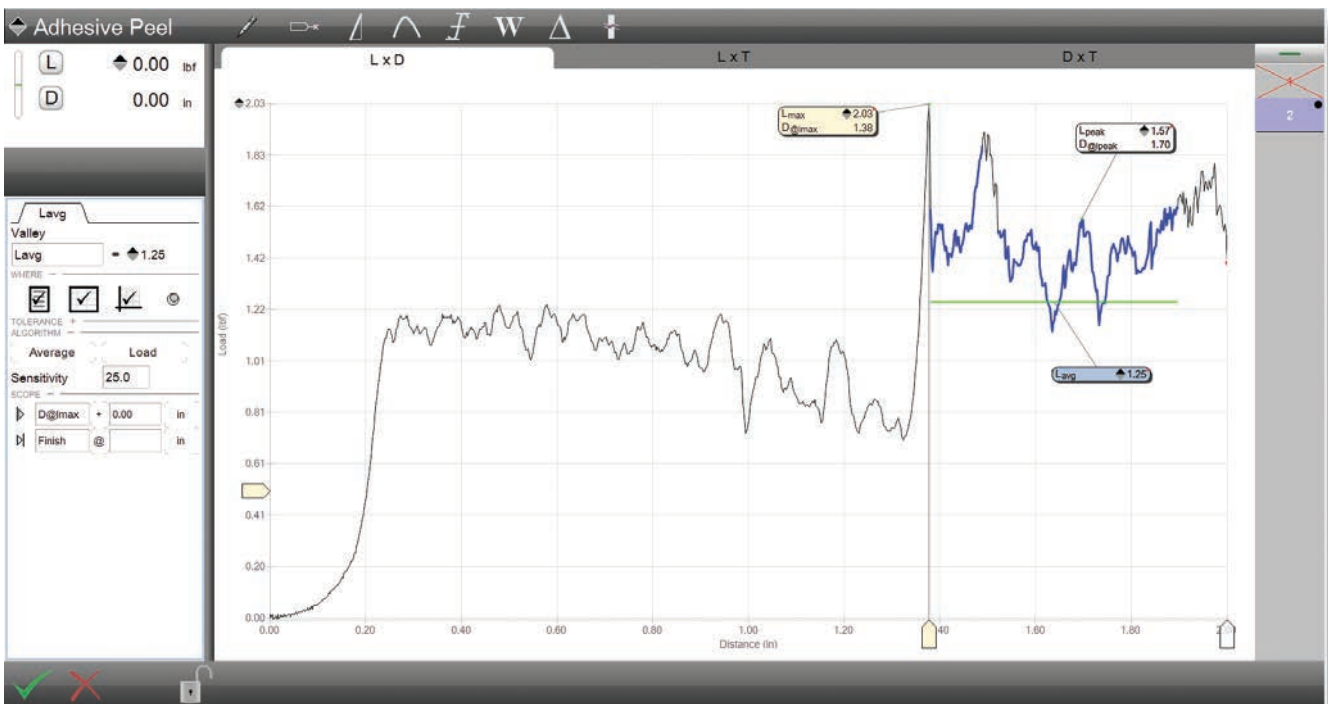

L2PLUS SOFTWARE

Your test step can include "exceptions" which help with test flow control. If an exception occurs the test run can automatically abort. Your test data may be saved and exported, or you can choose to disregard the test altogether.

Here the test exceptions are "abort if the Load reaches 4.00lbf, or if the sample breaks after first measuring 2.00lbf".

Two forms of Break analysis are supported:
%Drop from Maximum Load and Rate.

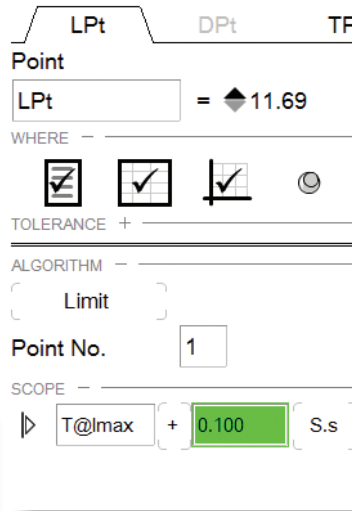
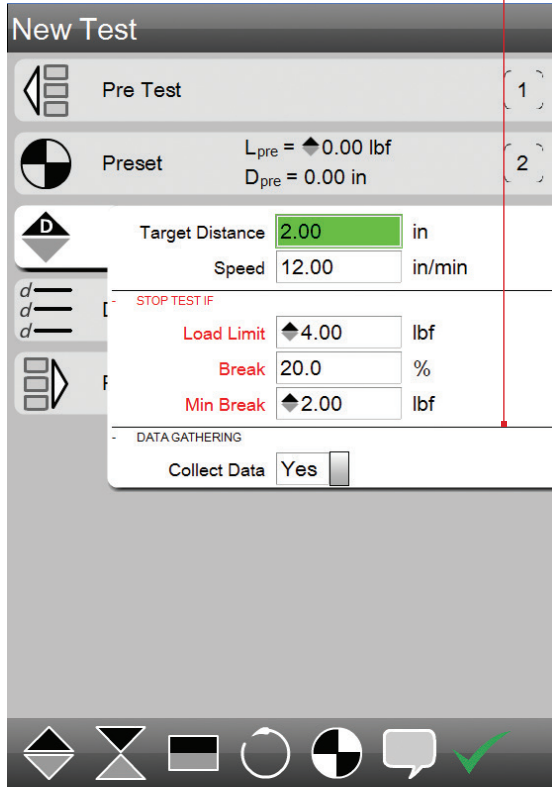

Scoping allows you to specify any point or segment of data from your graph for analysis. Measure based on load, distance and time.

Complex motion-control test steps may be performed, including load rate control. This test method lets you specify a load target and a velocity based on load rate. In this example, the target load is 15.00lbf and the test requires that you get to the target in 5 seconds, or a rate of 180.00 lbf/minute.

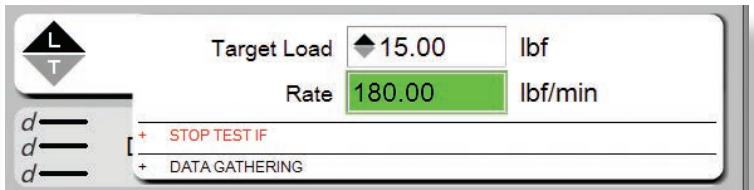

Make sure button is secured within test fixture

The Test has stopped because of an Exception
(press anywhere to continue)

System messages and prompts provide operators with alerts during testing. User prompts include ASK and TELL messages:

- ASK messages require an operator acknowledgement.
- TELL messages are displayed for a duration or until the operator acknowledges the message.

System messages display in red to alert the operator to alerts and warnings.

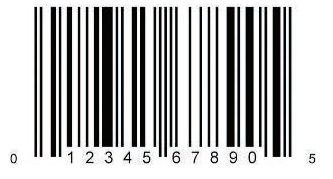

A bar code reader can be used to quickly load and launch your test setup. Ideal for busy, high-volume production applications where you are performing many test setups.

Measure these common results and more using your L2 Plus system:

- Absolute Peak
- Average Value (All Peaks)
- Average Value (Selected Peaks)
- Average Value (All Valleys)
- Average Value (Selected Valleys)
- Average Results (Regions)
- Break (Load)
- Break (Load/Extension Rate)
- Break (% Maximum)
- Coefficient of Friction
- Delta Creep
- Delta Relaxation
- Initial Peak
- Initial Valley
- Hold Preset Point
- Hysteresis Loss
- Slope Intersect
- Total Creep
- Total Relaxation
- User Calculations
- Work/Energy/Resilience

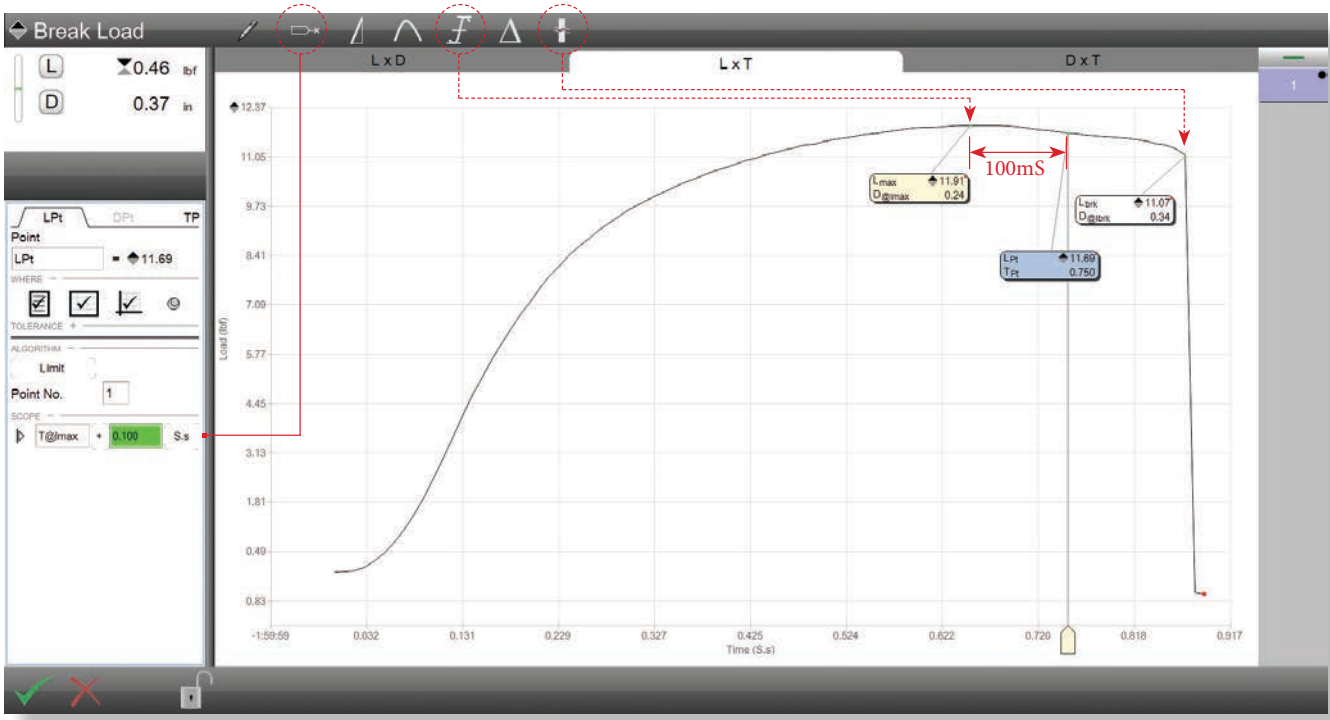

(Above) Anchoring is a scope feature. It allows you to easily measure from an existing result (anchor).

In this example, the load value is found at 100mS after the maximum load (Lmax). In the scoping operation for the point result (Lpt), the Lmax is used as an anchored result. The "+" sign signifies "after" the anchored Lmax. The scope value is specified as time (S.s) and entered as 0.1 second. You can scope on load, distance or time.

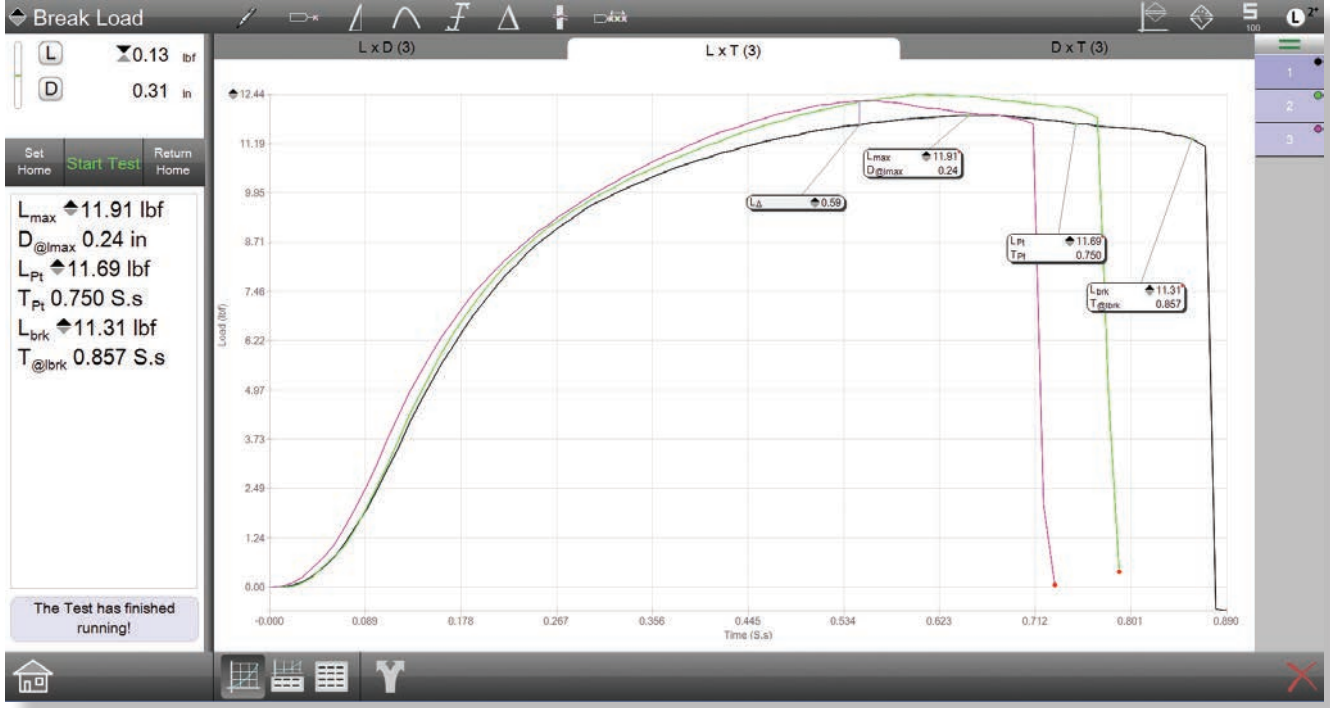

(Above) Using the "Multiview" function, you can measure using multiple graphs from your batch. Graph traces are overlaid onto one another and color-coded for identification. In this example, the delta variance is measured between the three test runs. The variance is measured at a point between the graph with the greatest value and the graph with the lowest value. This function can be used for "benchmark comparisons".

L1 SOFTWARE

Starrett L1 Systems represent our most-basic, computer-based force testing solution. Optimized for production and quality control testing, they are designed to be easy to setup, operate and maintain.

L1 Systems can be used to perform a wide variety of testing methods including:

- Load Limit Testing
- Distance Limit Testing
- Break Limit Testing
- Cyclic Count Testing
- Cyclic Duration Testing
- Constant Load Testing
- Constant Distance Testing
- Spring Testing

BASIC ARCHITECTURE

Your Starrett L1 System is comprised of the following:

- FMM Digital Force Tester
- Base clevis adapter kit
- USB 2.0 communication cable
- BLC Load Cell Sensor
- Load cell mounting block
- 2-in-1 Windows® 10 Tablet Computer
- Table computer to column mounting fixture
- L1 Application Software

Communication between the hardware is USB 2.0.

The 2-in-1 L1 tablet features a 10", high-resolution, touchscreen, color display with three USB 2.0 ports.

The L1 application software lets you create your test methods quickly using test templates that guide you through the test setup process. Create common test methods in seconds.



L1-550 system with FMM-550 test frame and L1 tablet and software. Test fixture and BLC Load Cell Sensor are optional.

L1 TEST TEMPLATES

The L1 System includes a set of common force measurement test templates. The templates have a common format consisting of these four test setup stages.

- Pre Test
- Test
- Data
- Post Test

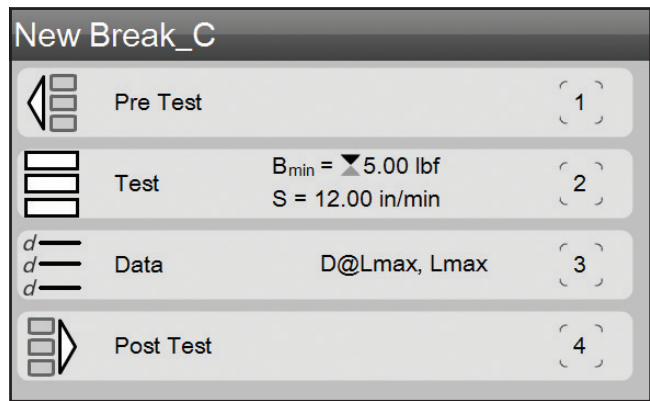

TEST SETUP ARCHITECTURE

All test setups include four common, easy-to-understand, menu-guided stages: Pre Test, Test, Data and Post Test.

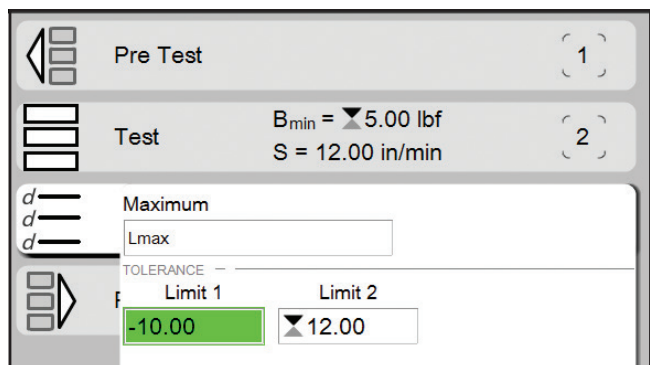
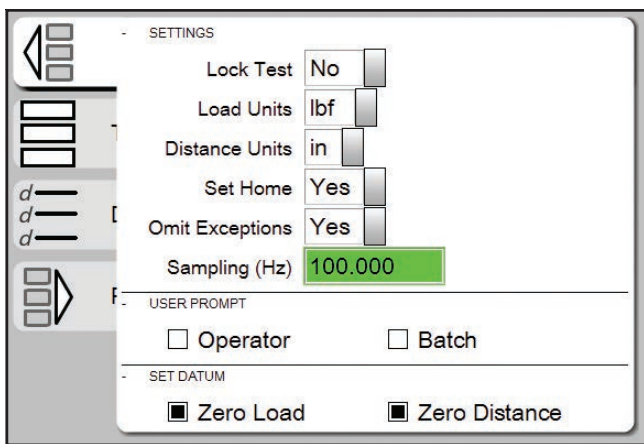

PRE TEST STAGE

The Pre Test stage supplies options you would perform prior to testing, for example, specifying the units needed to measure load and distance.

DATA STAGE

The Data stage is where you specify what results you want. For example, you can select Maximum Load, Distance @ Maximum Load, Distance @ Load Limit, Load @ Distance Limit and more. A list of values is displayed and you simply select the result you want. The Data stage is also where you can utilize tolerance limits for immediate "Pass/Fail" identification.

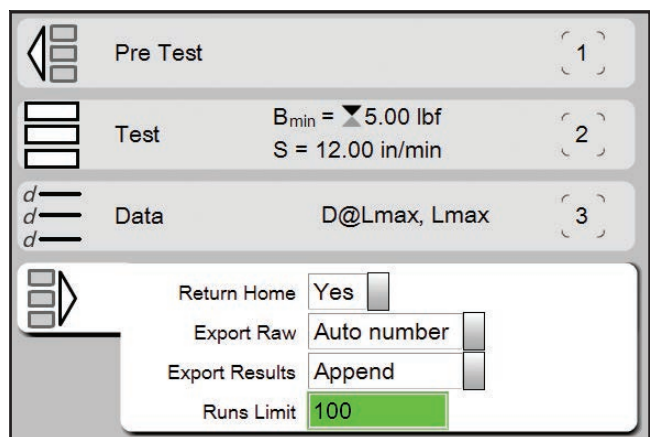
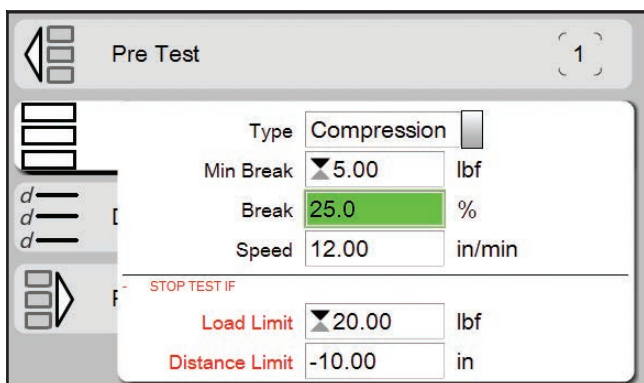

TEST STAGE

The Test stage is where you specify your testing requirements- what load you are using, what distance your crosshead will move, how fast your test speed is. Plus, you can easily add "exceptions". Exceptions are events that can be used to automatically stop your test, if they occur.

POST TEST STAGE

The Post Test stage lets you define what you want to do when the test concludes. You can export raw data or just the results and send to a network server. You can easily export directly to Microsoft® Excel® for custom report generation or analysis. Export information is saved as a .csv format for easy integration.

L1 SOFTWARE

When your L1 test method concludes, you can see the results you specified in your setup. Your L1 System will display results in these formats:

- Results View
- Graph View
- Data View
- Tolerance View
- Statistics View

RESULTS VIEW

Your results are displayed in a large, easy-to-read format organized for quick interpretation. The result and associated units of measure are displayed. During testing the active load and distance measurement is displayed. The crosshead speed and direction of travel is also displayed so the operator is aware of the current test status.

GRAPH VIEW

Load, Distance and Time can be used to view the data points used for your test. You may sample at rates up to 1000Hz and display your graph profile for your test. You can select a point on the graph and see the associated load, distance and time. You can also overlay multiple graphs to make graphical comparisons.

Your Test Name is displayed as well as the type of test: compression or tension.

DATA VIEW

Results can be displayed in a tabular format. This is ideal for a quick comparison of each test in a batch of tests performed throughout the shift or day. You can export directly from the Data view to Microsoft® Excel®.

TOLERANCE VIEW

When tolerance limits are used for "Pass/Fail" analysis, you can see your tolerance limits compared to actual results. You also see "Pass" or "Fail". Failed results are displayed in red text. And we supply a deviation bar graph that shows where your results measured compared to your tolerance limits.

STATISTICS VIEW

Common statistics such as mean, maximum, minimum, standard deviation and six sigma may be displayed for all test results.

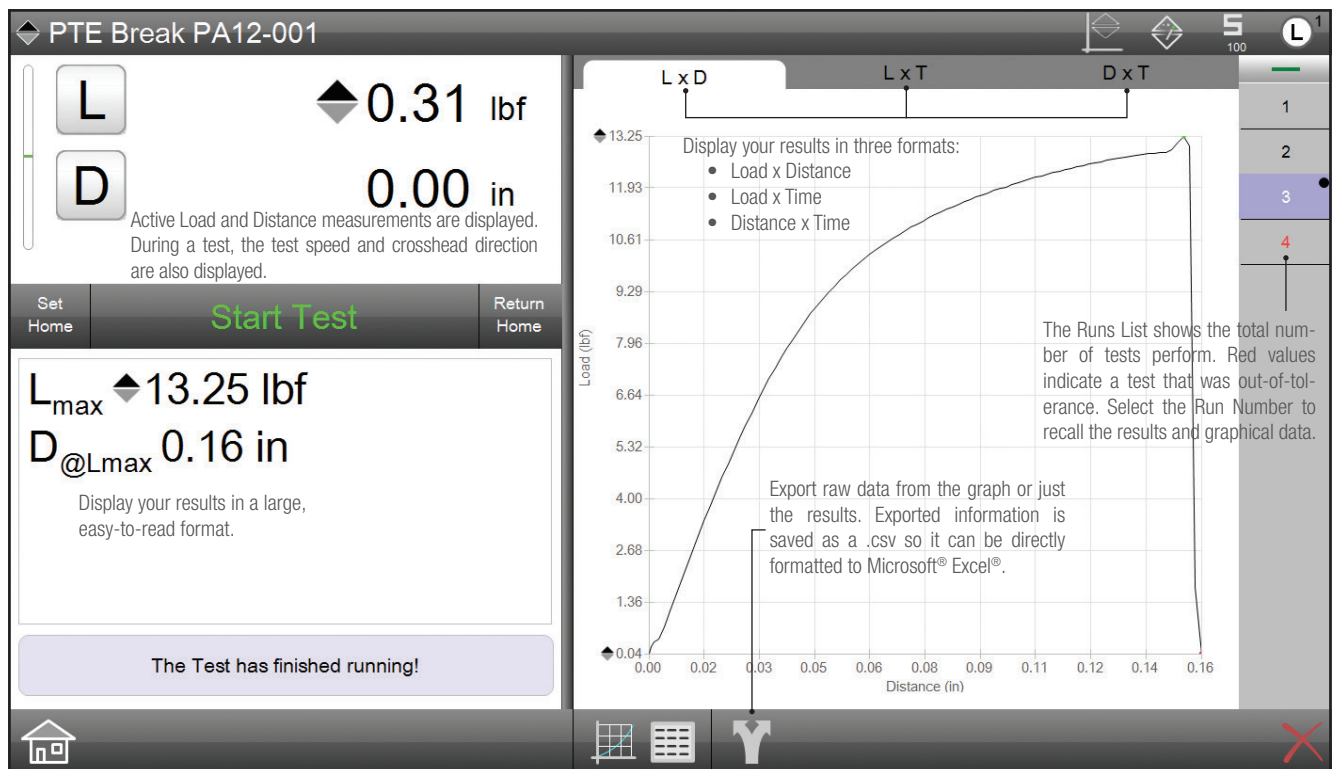

When the test concludes, your L1 software shows your results in numerical and graphical formats. Essential measurements are displayed in easy-to-interpret formats. You can Start and Stop a test using the touchscreen display; manually set the home position and return the crosshead to home position, and zero your load (L) and distance (D) measurements.



Compare the graphical results of multiple tests that you select. Individual graphs are color-coded and referenced to the test in the Runs List. You can also retrieve archived tests for making a graphical comparison. For example, you can compare a "benchmark" result from a year ago to a current result.

◆ PTE Break PA12-001

L 0.31 lbf
D 0.00 in

Start Test

L_{max} ◆ 15.65 lbf
D@L_{max} 4.35 in

The Test has finished running!

Run	Coef	Units	Actual	Limit 1	Limit 2	Deviation	P/F
1	Lmax	lbf	◆ 12.87	◆ 10.00	◆ 15.00	←→	Pass
1	D@Lmax	in	3.19				
2	Lmax	lbf	◆ 12.97	◆ 10.00	◆ 15.00	←→	Pass
2	D@Lmax	in	3.10				
3	Lmax	lbf	◆ 13.25	◆ 10.00	◆ 15.00	←→	Pass
3	D@Lmax	in	0.16				
4	Lmax	lbf	◆ 15.65	◆ 10.00	◆ 15.00	←→	Fail
4	D@Lmax	in	4.35				

"Pass" and "Fail" status is immediate when using tolerances. Out-of-tolerance results are displayed in red.

Select the Data view and view results in a tabular format. Easily switch to Graph view by selecting the Graph symbol.

Display results in a tabular format complete with your tolerance limits. Test results that are out-of-tolerance are prominently displayed in red. Out-of-tolerance results are identified in the table, large results view and on the graph view in the Runs List. You can also display statistics on selected test runs. Calculate and display Minimum, Maximum, Mean and Standard Deviation with a single click.

L1 SOFTWARE - SPRING TEMPLATES

ECONOMICAL DIGITAL SPRING TESTING.

Starrett L1 Software's spring templates represent our most basic digital testing solution for compression and extension springs. These systems are ideal for high-volume production testing and individuals looking for more consistent testing results over manual testing methods.

Two types of test methods are supplied for compression and extension springs. Easy-to-use test templates let you create your test setup in seconds. The small footprint make L1 systems ideal for lean manufacturing environments or in-situ production locations.

With the L1 system, you can measure:

- Spring rate
- Spring constant
- Free length
- Solid Height
- Initial tension

Make use of tolerances to determine immediate "Pass/fail" results. View results graphically or in tabular formats. You can also print out custom reports and export data to Microsoft Excel or SPC software such as ProLink's QC CALC application.

SOFTWARE FEATURES

- Use preconditioning options to exercise your spring prior to testing. You can scrag for a number of cycles or duration. You can also compress to a load set and hold for a duration.
- Single or dual limit tests may be used. You may specify a target load or target height/length to determine spring rate, spring constant, load and length at target limits, initial tension and measured free length.
- The Statistics View displays key statistical information for your batch including mean, range, standard deviations and tolerance results.

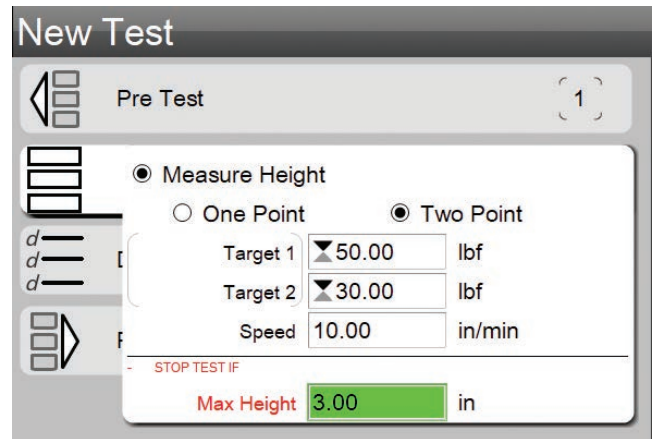

Test templates make test setup simple and fast. One- and two-point methods may be used. Measure free length by selecting the combo button. Test targets may be load- or height-based.



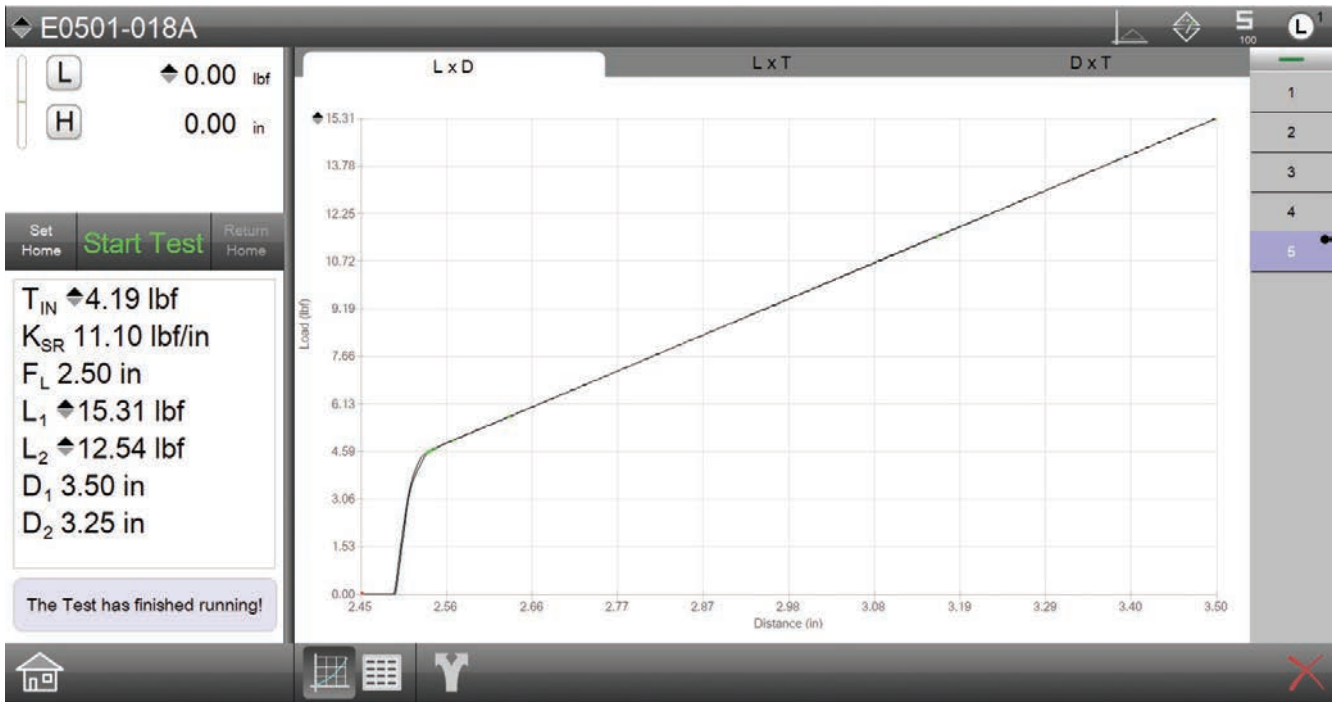

E0501-018A
 L 0.00 lbf
 H 2.45 in
 Start Test
 T_{IN} 4.18 lbf
 K_{SR} 11.10 lbf/in
 F_L 2.50 in
 L₁ 15.31 lbf
 L₂ 12.53 lbf
 D₁ 3.50 in
 D₂ 3.25 in
 The Test has finished running!

K _{SR} (lbf/in)	T _{IN} (lbf)	F _L (in)	L ₁ (lbf)	L ₂ (lbf)	D ₁ (in)	D ₂ (in)
11.09	3.98	2.47	15.31	12.54	3.50	3.25
11.09	4.20	2.50	15.32	12.54	3.50	3.25
11.09	4.18	2.50	15.31	12.54	3.50	3.25
11.10	4.18	2.50	15.31	12.53	3.50	3.25

Max	4.20	2.50	15.32	12.54	3.50	3.25
Min	3.98	2.47	15.31	12.53	3.50	3.25
Range	0.22	0.03	0.01	0.01	0.00	0.00
Average	4.13	2.49	15.31	12.54	3.50	3.25
Std Dev	0.10	0.01	0.01	0.01	0.00	0.00
6 Sigma	0.62	0.09	0.03	0.03	0.00	0.00

(Top) Display your results with a full graph for your test. You can display three graph types: Load x Height, Load x Time or Distance x Time. You can also overlay graphs to compare the graph profiles. You can also print out a report with your graph and the results for each test with a single key-press.

(Bottom) Display your results in a tabular format. Tabular results may be displayed with tolerance limits and "pass/fail" indication. You can also display statistical results for individual tests or for all the tests performed for a batch. Export result or your raw data with a single key-press.

AUTOMATIC BUILDER OPTION

Switch SW091279

Pre Test		1
Preset	L _{pre} = 0.00 lbf D _{pre} = 0.00 in	2
Push	L _{lim} = -0.10 lbf S = 1.00 in/min	3
Preset	D _{pre} = 0.00 in	4
Push	I _{line} = Line 3 L _{level} = High	5
If	Cond = Formula Tol Lmax	6
Else		7
Output	O _{trig} = Test Fail O _{line} = Line 4 (High)	8
End	Error = No	9
Data	Lmax, D@lmax, T@lmax	10
Post Test		11

Starrett Lx systems can be interfaced with ancillary instrumentation for factory automation applications or where more advanced and complex measurements are necessary.

The optional Automation Builder software packages can be used for interfacing with instrumentation and equipment through digital and analog I/O signals.

Push I_{line} = Line 3
L_{level} = High 5

Condition Formula

Tol Lmax

Calculator interface with buttons for mathematical operations and functions like Sin, Cos, Tan, and logical operators.

(Above) A conditional branching occurs when the Lmax result is out-of-tolerance. This will cause a message to display to the operator and it will cause a signal annunciator to light red for a failed test sample.

Else 7

Condition Test Fail

Output Line Line 4

Line State High

The Automation Builder can also be used to incorporate conditional logic within your test setup. Conditional logic can be used to establish If/Else relationships, including the ability to automatically adjust test setup functionality based on events that occur during a test run.

Digital I/O can be used for contact closure testing. You can measure and determine the precise load that caused the "make" or "break" in an electronic component or switch. You may also use conditional logic combined with the digital outputs to light an annunciator based on a tolerance result, or control devices like rotary tables.



The Formula Builder allows you to construct complex, derived results using arithmetic, trigonometric and logarithmic expressions. The Formula Builder is standard in L3 systems and optional for the L2Plus software.

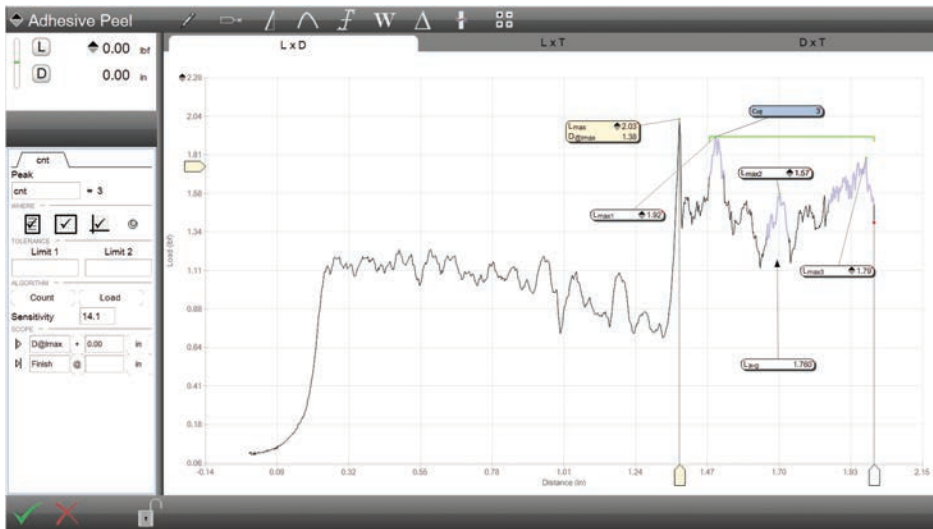

This example shows a full graph view of an adhesive test. Three peaks are identified based on the sensitivity of 14.1 after the Lmax (maximum peak).

The qualified peaks are highlighted in blue and identified as Lmax1, Lmax2 and Lmax3.

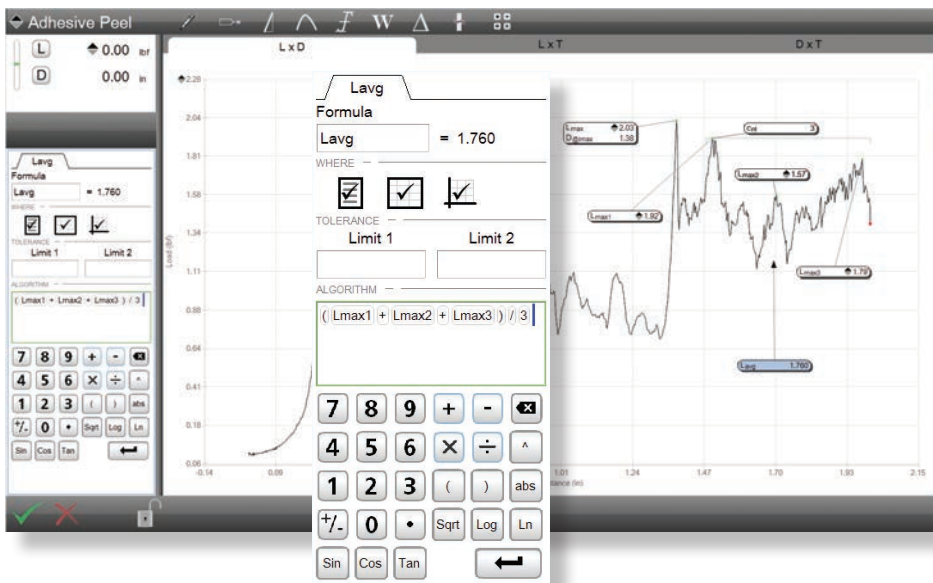

Using the Formula Builder, an expression was created that is an average of the three Lmax values only. The Lavg in this example application does not average all data points, but only the Lmax values.

The formula you create is evaluated real-time. Syntax errors are noted by displaying a red line around the formula input box. If the formula is correct, the line is green.

The functions and features available using the optional Automation Builder software are shown in the table.

The Formula Builder is supplied standard on L3 systems only.

Automation Builder Software Option

Measurement Capabilities	L3	L2 Plus
Use Digital I/O	○	○
Use Analog I/O (requires MMx test frames)	○	○
Use Command and Conditional Logic	○	○
Formula Builder		
Create Basic Expressions using Add, Subtract, Multiple and Divide	Std ¹	○
Create Mathematical Expressions using Algebraic, Trigonometric and Logarithmic functions	Std ¹	○

Notes: (1) The Formula Builder function is supplied standard on L3 systems only. The Formula Builder is included in the optional Automation Builder software for L2 Plus system.

Advanced mathematical expressions using algebraic, trigonometric and logarithmic functions are available on L3 and L2 Plus systems only.

DIGITAL FORCE CONTROLLER

FOR ADVANCED AND BASIC TESTING APPLICATIONS

Starrett digital force gages can be used as handheld force gages for basic applications or as a force sensor when used with a FMM Digital Force Tester, MTL and MTH Manual Tester. Listed are the various test methods that can be performed:

- **Limit Testing** - Use load, distance or a break condition and report results at the limit including maximum load and distance at maximum load.
- **Load, Distance, and Break tests can be entered in easy to use menus with the option to auto zero load and distance at the start of the test.**

Tests	
Test Mode	
Distance	
Type	Tension
Target	50.00
Speed	25.00

Easy Test Setup

As a controller, the DFC can be used to measure load and control the FMM Test Frame. Create Load, Distance and Break Limit test methods in seconds.

▶		☰		▼ 3	
▭		⊕		50.00mm	
L	◆	50.20		N	
D		50.00		mm	
▬					

Comprehensive Results

At the completion of your test, the DFC will display load and distance results. These can be saved to memory or exported for reporting.

DFC DIGITAL FORCE CONTROLLER

The DFC is a revolutionary concept for force measurement using a handheld force gage. The DFC may be used as a high-accuracy handheld force gage or as a digital controller for use with the FMM Digital Force Testers. The DFC can serve as a universal interface where you set up your tests and where you configure load limits, distance limits, break limits, crosshead travel direction, crosshead speed and more. The DFC features a measurement accuracy of 0.1% full scale with internal data sampling at 8kHz. Display resolution is 10,000:1. The DFC features Bluetooth®, USB and RS-232 communications plus digital I/O.



Starrett® 121 Crescent Street
Athol, MA 01331
www.starrett.com

MODEL: MLC-50K	S/N: 459447A
CAPACITY: 50 kN	OUTPUT: 4.227 mV/V



LOAD CELL SENSORS

LOAD CELL SENSORS

Starrett offers a full range of precision load cell sensors for material testing, force analysis and force measurement applications. Starrett load cells are compliant with IEEE 1451.4 and meet or exceed ASTM E4, BS 1610, ISO 7500-1 and EN 10002-2.

Measurement accuracies of $\pm 0.05\%$ of reading down to 1/100 of sensor capacity may be achieved. Sensors are supplied with a NIST-traceable Certificate of Calibration.

BLC LOAD CELL SENSORS

Starrett BLC load cell sensors are full-bridge, temperature compensated, strain gage instruments designed and optimized for basic force testing applications. These S-beam sensors feature high axial stiffness and minimal deflection at full capacity which leads to improved measurement accuracy.

The BLC sensors are general purpose sensors available in capacities from 2lbf to 500lbf (10 to 2500N). These sensors are used exclusively with FMM motorized test frames.



BLC - Basic Force Measurement S-beam Sensors

Model No.	Load Capacity			Safe Overload % Full Scale	Full Scale Deflection		Height		Width		Thread mm
	N	KGF	LBF		in	mm	in	mm	in	mm	
BLC-2	10	1	2	150	0.009	0.22	3.0	76.2	3.0	76.2	M6 x 1-6H
BLC-5	20	2	5	150	0.008	0.21	3.0	76.2	3.0	76.2	M6 x 1-6H
BLC-10	50	5	10	150	0.007	0.18	3.0	76.2	3.0	76.2	M6 x 1-6H
BLC-20	100	10	20	150	0.007	0.18	2.0	50.8	2.0	50.8	M6 x 1-6H
BLC-50	250	25	50	150	0.006	0.15	2.0	50.8	2.0	50.8	M6 x 1-6H
BLC-100	500	50	110	150	0.003	0.08	2.0	50.8	2.0	50.8	M6 x 1-6H
BLC-200	1000	100	225	150	0.003	0.08	2.0	50.8	2.0	50.8	M6 x 1-6H
BLC-500	2500	250	550	150	0.005	0.13	2.0	50.8	2.0	50.8	M12 x 1.75-5H

NOTES

Load measurement accuracy is $\pm 0.1\%$ of load cell capacity. Display resolution is 10,000:1.

Starrett recommends on-site verification of accuracy during installation. Sensor calibration should be performed at least annually.



MLC LOAD CELL SENSORS

The Starrett MLC load cell sensors are full-bridge, temperature compensated, strain gage instruments designed and optimized for material testing applications. These low profile sensors feature high axial stiffness and minimal deflection at full capacity which leads to improved measurement accuracy.

The MLC are general purpose sensors available in capacities from 125N to 50kN. For FMS, MMS, FMD, or MMD test frames.

MLC Series - Low Profile Sensors

Model Number	Load Capacity			Safe Overload % Full Scale	Full Scale Deflection		Height ¹		Width		Thread mm
	N	KGF	LBF		mm	inch	mm	inch	mm	inch	
MLC-125	125	12.5	28	150	0.08	0.003	38.1	1.5	69.8	2.75	M6 x 1-6H
MLC-250	250	25	56	150	0.08	0.003	38.1	1.5	69.8	2.75	M6 x 1-6H
MLC-500	500	50	112	150	0.08	0.003	38.1	1.5	69.8	2.75	M6 x 1-6H
MLC-1000	1000	100	225	150	0.08	0.003	38.1	1.5	69.8	2.75	M6 x 1-6H
MLC-1500	1500	150	337	150	0.03	0.001	63.51	2.51	104.8	4.13	M16 x 2-4H
MLC-2500	2500	250	562	150	0.03	0.001	63.51	2.51	104.8	4.13	M16 x 2-4H
MLC-5K	5000	500	1124	150	0.03	0.001	63.51	2.51	104.8	4.13	M16 x 2-4H
MLC-10K	10,000	1000	2248	150	0.03	0.001	63.51	2.51	104.8	4.13	M16 x 2-4H
MLC-25K	25,000	2500	5620	150	0.05	0.002	63.51	2.51	104.8	4.13	M16 x 2-4H
MLC-50K	50,000	5000	11,250	150	0.05	0.002	63.51	2.51	104.8	4.13	M16 x 2-4H

NOTES

¹ Dimension includes the base adapter. These MLC sensors are supplied with the base adapter standard. Base adapters are recommended for any MLC sensor.

Load measurement accuracy is $\pm 0.05\%$ of reading down to 1/100 of load cell capacity. Display resolution is 10,000:1.

Starrett recommends on-site verification of accuracy during installation. Sensor calibration should be performed at least annually.

LOAD CELL SENSORS

FLC LOAD CELL SENSORS

Three models of s-beam load cell sensors are also available. These are all full bridge, temperature compensated strain gage instruments, designed for force measurement applications, but suitable for some material testing applications. For FMS, MMS, FMD, or MMD test frames.

PREMIUM MODELS

Ideal for low load applications, these sensors have a safe overload rating of 1000% of the sensor's load capacity.

SEALED MODELS

These models are suitable for applications in non-laboratory environments where dirt, oil, dust and debris may be present.

ECONOMY MODELS

When price is an issue, these general purpose load cell sensors are economical and suitable for most general purpose force measurement applications.



FLC-P Series - "Premium" S-beam Sensors											
Model Number	Load Capacity			Safe Overload % Full Scale	Full Scale Deflection		Height		Width		Thread mm
	N	KGF	LBF		mm	inch	mm	inch	mm	inch	
FLC-5P	5	0.5	1	1000	0.4	0.014	63.0	2.48	59.2	2.33	M6 x 1-6H
FLC-10P	10	1	2	1000	0.3	0.012	63.0	2.48	59.2	2.33	M6 x 1-6H
FLC-25P	25	2.5	5	1000	0.3	0.012	63.0	2.48	59.2	2.33	M6 x 1-6H
FLC-50P	50	5	11	1000	0.2	0.009	63.0	2.48	59.2	2.33	M6 x 1-6H
FLC-100P	100	10	22	1000	0.2	0.009	63.0	2.48	59.2	2.33	M6 x 1-6H
FLC-250P	250	25	56	1000	0.2	0.009	63.0	2.48	59.2	2.33	M6 x 1-6H

NOTES

Load measurement accuracy is $\pm 0.1\%$ of load cell capacity. Display resolution is 10,000:1.
Starrett recommends on-site verification of accuracy during installation. Sensor calibration should be performed at least annually.

FLC Series - "Sealed" S-beam Sensors											
Model Number	Load Capacity			Safe Overload % Full Scale	Full Scale Deflection		Height		Width		Thread mm
	N	KGF	LBF		mm	inch	mm	inch	mm	inch	
FLC-500	500	50	112	150	0.10	0.004	63.0	2.5	50.8	2.0	M6 x 1-6H
FLC-1000	1000	100	225	150	0.15	0.006	63.0	2.5	50.8	2.0	M6 x 1-6H
FLC-2000	2000	200	450	150	0.13	0.005	76.2	3.0	50.8	2.0	M12 x 1.75-5H
FLC-2500	2500	250	562	150	0.13	0.005	76.2	3.0	50.8	2.0	M12 x 1.75-5H
FLC-5KN	5000	500	1124	150	0.13	0.005	76.2	3.0	50.8	2.0	M12 x 1.75-5H

NOTES

Load measurement accuracy is $\pm 0.1\%$ of load cell capacity. Display resolution is 10,000:1.
Starrett recommends on-site verification of accuracy during installation. Sensor calibration should be performed at least annually.

FLC-E Series - "Economy" S-beam Sensors											
Model Number	Load Capacity			Safe Overload % Full Scale	Full Scale Deflection		Height		Width		Thread mm
	N	KGF	LBF		mm	inch	mm	inch	mm	inch	
FLC-50E	50	5	11	150	0.08	0.003	63.5	2.5	50.8	2.0	M6 x 1-6H
FLC-100E	100	10	22	150	0.08	0.003	63.5	2.5	50.8	2.0	M6 x 1-6H
FLC-200E	200	20	45	150	0.08	0.003	63.5	2.5	50.8	2.0	M6 x 1-6H
FLC-500E	500	50	112	150	0.10	0.004	63.5	2.5	50.8	2.0	M6 x 1-6H
FLC-1000E	1000	100	225	150	0.15	0.006	63.5	2.5	50.8	2.0	M6 x 1-6H
FLC-2000E	2000	200	450	150	0.15	0.006	76.2	3.0	50.8	2.0	M12 x 1.75-5H
FLC-2500E	2500	250	562	150	0.13	0.005	76.2	3.0	50.8	2.0	M12 x 1.75-5H
FLC-5000E	5000	500	1124	150	0.13	0.005	76.2	3.0	50.8	2.0	M12 x 1.75-5H

NOTES

Load measurement accuracy is $\pm 0.1\%$ of load cell capacity. Display resolution is 10,000:1.
Starrett recommends on-site verification of accuracy during installation. Sensor calibration should be performed at least annually.

690

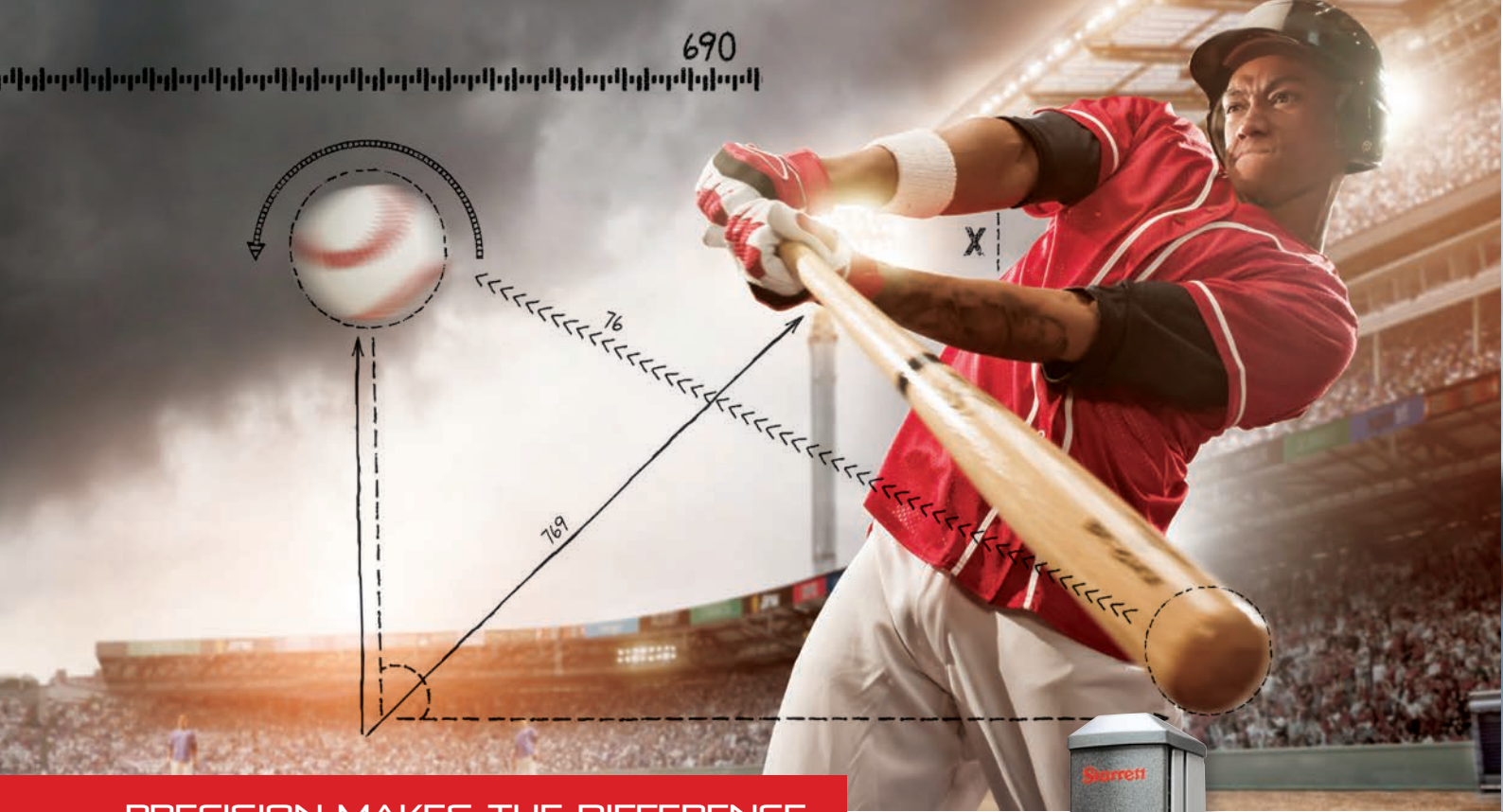
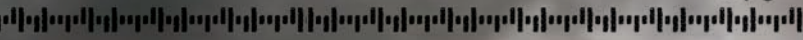

PRECISION MAKES THE DIFFERENCE

EXCEED YOUR CAPABILITIES.

The Starrett FMS incorporates new performance-based capabilities and user-friendly features to help you perform critical force tests with greater accuracy and efficiency.

It can perform all of your basic force measurement tests, as well as more complex multi-stage tests to international standards.



Model FMS5000

Starrett®

(978) 249-3551 • starrett.com

Follow us!





PLATENS

PLATENS

Starrett offers a variety of standard platens for various forms of compression testing. Standard platen types are:

- Circular Platens
- Rectangular Platens
- Perforated Platens for Foam Testing
- Self-aligning Platens for Springs

Starrett platens are made of aluminum or steel. Most of our platens mount using a 15.9mm clevis and are secured with a locking ring and grip pin. We also offer threaded platens which attach using a set screw or adapter screw.

Starrett can also custom-design platens for your specific requirements and applications.



Model No.	Load Capacity			Dimension	Material	Type
	N	KGf	LBF			
Circular Platens						
PLATEN-23A-56-1	20k	2,000	4,500	56mm ø	Aluminium	Clevis
PLATEN-23A-96-1	20k	2,000	4,500	96mm ø	Aluminium	Clevis
PLATEN-23A-116-1	20k	2,000	4,500	116mm ø	Aluminium	Clevis
PLATEN-23A-156-1	20k	2,000	4,500	156mm ø	Aluminium	Clevis
PLATEN-23A-196-1	20k	2,000	4,500	196mm ø	Aluminium	Clevis
PLATEN-23A-246-1	20k	2,000	4,500	246mm ø	Aluminium	Clevis
PLATEN-23A-296-1	20k	2,000	4,500	296mm ø	Aluminium	Clevis
PLATEN-23S-56-1	20k	2,000	4,500	56mm ø	Steel	Clevis
PLATEN-23S-96-1	20k	2,000	4,500	96mm ø	Steel	Clevis
PLATEN-23S-116-1	20k	2,000	4,500	116mm ø	Steel	Clevis
PLATEN-23S-156-1	20k	2,000	4,500	156mm ø	Steel	Clevis
PLATEN-23S-196-1	20k	2,000	4,500	196mm ø	Steel	Clevis
PLATEN-23S-246-1	20k	2,000	4,500	246mm ø	Steel	Clevis
PLATEN-23S-296-1	20k	2,000	4,500	296mm ø	Steel	Clevis
PLATEN-23S-56-3	50k	5,000	11,000	56mm ø	Steel	Clevis
PLATEN-23S-96-3	50k	5,000	11,000	96mm ø	Steel	Clevis
PLATEN-23S-116-3	50k	5,000	11,000	116mm ø	Steel	Clevis
PLATEN-23S-156-3	50k	5,000	11,000	156mm ø	Steel	Clevis
PLATEN-23S-196-3	50k	5,000	11,000	196mm ø	Steel	Clevis
PLATEN-23S-246-3	50k	5,000	11,000	246mm ø	Steel	Clevis
PLATEN-23S-296-3	50k	5,000	11,000	296mm ø	Steel	Clevis
MLX-PLATE-TA-50	1500	150	330	50mm ø	Aluminium	M6
MLX-PLATE-TS-100	2500	250	550	100mm ø	Steel	M10
Rectangular Platens						
PLATEN-36A-50-1	20k	2,000	4,500	50 x 50mm	Aluminium	Clevis
PLATEN-36A-100-1	20k	2,000	4,500	100 x 100mm	Aluminium	Clevis
PLATEN-36A-120-1	20k	2,000	4,500	120 x 120mm	Aluminium	Clevis
PLATEN-36A-150-1	20k	2,000	4,500	150 x 150mm	Aluminium	Clevis
PLATEN-36A-200-1	20k	2,000	4,500	200 x 200mm	Aluminium	Clevis
PLATEN-36A-250-1	20k	2,000	4,500	250 x 250mm	Aluminium	Clevis
PLATEN-36A-300-1	20k	2,000	4,500	300 x 300mm	Aluminium	Clevis
PLATEN-36A-400-1	20k	2,000	4,500	400 x 400mm	Aluminium	Clevis
PLATEN-36S-100-1	20k	2,000	4,500	100 x 100mm	Steel	Clevis
PLATEN-36S-196-1	20k	2,000	4,500	196 x 196mm	Steel	Clevis
PLATEN-36S-246-1	20k	2,000	4,500	246 x 246mm	Steel	Clevis
PLATEN-36S-296-1	20k	2,000	4,500	296 x 296mm	Steel	Clevis
PLATEN-36S-396-1	20k	2,000	4,500	396 x 396mm	Steel	Clevis
Perforated Platens for Foam						
PLATEN-36LA-150-1	20k	2,000	4,500	150 x 150mm	Aluminium	Clevis
PLATEN-36LA-200-1	20k	2,000	4,500	200 x 200mm	Aluminium	Clevis
PLATEN-36LA-400-1	20k	2,000	4,500	400 x 400	Aluminium	Clevis
Self-Aligning Platens for Springs						
PLATEN-223S-56-1	20k	2,000	4,500	56mm ø	Steel	Clevis
PLATEN-223S-96-1	20k	2,000	4,500	96mm ø	Steel	Clevis
PLATEN-223S-116-1	20k	2,000	4,500	116mm ø	Steel	Clevis
PLATEN-223S-156-1	20k	2,000	4,500	156mm ø	Steel	Clevis

IMPORTANT

The standard clevis diameter is 15.9mm. This clevis is suitable for load capacities up to 30kN (6600lbf). Aluminium and steel platens may be used up to 20kN except where noted.

If higher capacities are required (50kN), the clevis diameter must be 31.8mm.

CIRCULAR PLATENS

These general purpose compression platens are available in aluminum or steel. They mount to a 15.9mm clevis and are secured with a locking ring and grip pin.

ALUMINUM

- For compression testing applications on soft materials
- Surface has concentric grooves
- Anodized finish
- Operating Temperatures -94° to 356°F (-70° to 180°C)



PLATENS

Circular Platens- Aluminum

Model No.	Load Capacity			Diameter ϕ		Weight (each)		Clevis Type mm	Supply
	N	KGF	LBF	in	mm	lbs	kgs		
PLATEN-23A-56-1	20,000	2,000	4,500	2.2	56	0.2	0.1	15.9	2
PLATEN-23A-96-1	20,000	2,000	4,500	3.8	96	0.7	0.3	15.9	2
PLATEN-23A-116-1	20,000	2,000	4,500	4.6	116	0.9	0.4	15.9	2
PLATEN-23A-156-1	20,000	2,000	4,500	6.2	156	1.3	0.6	15.9	2
PLATEN-23A-196-1 ¹	20,000	2,000	4,500	7.7	196	2.7	1.2	15.9	2
PLATEN-23A-246-1 ¹	20,000	2,000	4,500	9.7	246	3.3	1.5	15.9	2
PLATEN-23A-296-1 ¹	20,000	2,000	4,500	11.6	296	7.3	3.3	15.9	2

Note 1: Platen cannot be used on Starrett single column test frame. Use on Starrett dual column test frames only.

DIMENSIONS

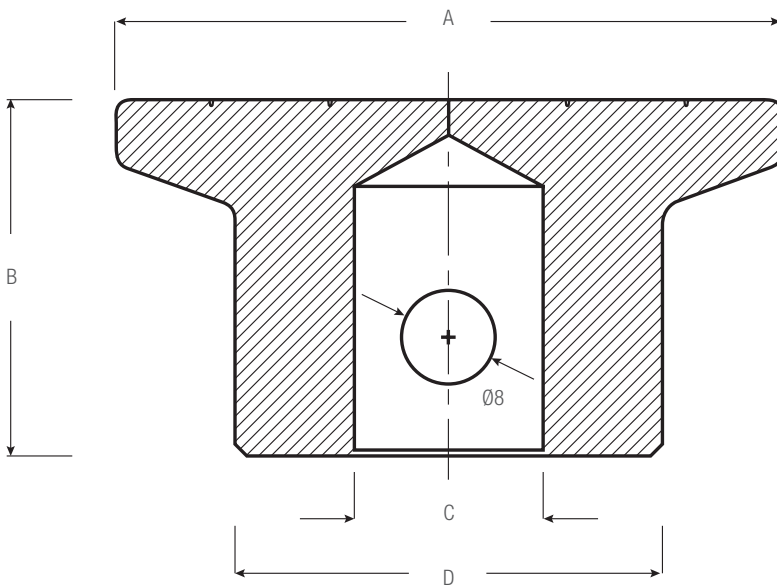

Circular Platens- Aluminum

Model No.	A	B	C	D
PLATEN-23A-56-1	56mm	36mm	15.9mm	34mm
PLATEN-23A-96-1	96mm	36mm	15.9mm	34mm
PLATEN-23A-116-1	116mm	36mm	15.9mm	34mm
PLATEN-23A-156-1	156mm	36mm	15.9mm	34mm
PLATEN-23A-196-1 ¹	196mm	36mm	15.9mm	34mm
PLATEN-23A-246-1 ¹	246mm	36mm	15.9mm	34mm
PLATEN-23A-296-1 ¹	296mm	36mm	15.9mm	34mm

Note¹: Platen cannot be used on Starrett single column test frame. Use on Starrett dual column test frames only.

CIRCULAR PLATENS

STEEL

- For compression testing applications on hard materials 58 HRC
- Surface has concentric grooves
- Black Phosphate finish
- Operating Temperatures 0° to 350°C (32° to 662°F)



PLATENS

Circular Platens- Steel

Model No.	Load Capacity			Diameter ϕ		Weight (each)		Clevis Type mm	Supply
	N	KGF	LBF	in	mm	lbs	kgs		
PLATEN-23S-56-1	20,000	2,000	4,500	2.2	56	0.7	0.3	15.9	2
PLATEN-23S-96-1	20,000	2,000	4,500	3.8	96	1.6	0.7	15.9	2
PLATEN-23S-116-1	20,000	2,000	4,500	4.6	116	2.4	1.1	15.9	2
PLATEN-23S-156-1	20,000	2,000	4,500	6.2	156	3.5	1.6	15.9	2
PLATEN-23S-196-1	20,000	2,000	4,500	7.7	196	8.8	4	15.9	2
PLATEN-23S-246-1 ¹	20,000	2,000	4,500	9.7	246	9.5	4.3	15.9	2
PLATEN-23S-296-1 ¹	20,000	2,000	4,500	11.6	296	19.9	9	15.9	2
PLATEN-23S-56-3	50,000	5,000	11,000	2.2	56	0.7	0.3	31.8	2
PLATEN-23S-96-3	50,000	5,000	11,000	3.8	96	1.6	0.7	31.8	2
PLATEN-23S-116-3	50,000	5,000	11,000	4.6	116	2.4	1.1	31.8	2
PLATEN-23S-156-3	50,000	5,000	11,000	6.2	156	3.5	1.6	31.8	2
PLATEN-23S-196-3	50,000	5,000	11,000	7.7	196	8.8	4	31.8	2
PLATEN-23S-246-3 ¹	50,000	5,000	11,000	9.7	246	9.5	4.3	31.8	2
PLATEN-23S-296-3 ¹	50,000	5,000	11,000	11.6	296	19.9	9	31.8	2

Note¹: Platen cannot be used on Starrett single column test frame. Use on Starrett dual column test frames only.

DIMENSIONS

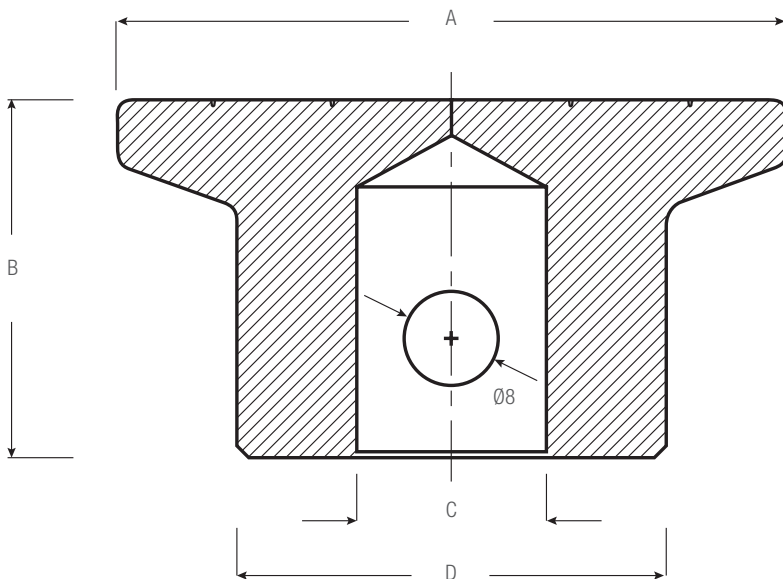

Circular Platens- Steel

Model No.	A	B	C	D
PLATEN-23S-56-1	56mm	36mm	15.9mm	34mm
PLATEN-23S-96-1	96mm	36mm	15.9mm	34mm
PLATEN-23S-116-1	116mm	36mm	15.9mm	34mm
PLATEN-23S-156-1	156mm	36mm	15.9mm	34mm
PLATEN-23S-196-1 ¹	196mm	36mm	15.9mm	34mm
PLATEN-23S-246-1 ¹	246mm	36mm	15.9mm	34mm
PLATEN-23S-296-1 ¹	296mm	36mm	15.9mm	34mm
PLATEN-23S-56-3	56mm	36mm	31.8mm	34mm
PLATEN-23S-96-3	96mm	36mm	31.8mm	34mm
PLATEN-23S-116-3	116mm	36mm	31.8mm	34mm
PLATEN-23S-156-3	156mm	36mm	31.8mm	34mm
PLATEN-23S-196-3 ¹	196mm	36mm	31.8mm	34mm
PLATEN-23S-246-3 ¹	246mm	36mm	31.8mm	34mm
PLATEN-23S-296-3 ¹	296mm	36mm	31.8mm	34mm

Note¹: Platen cannot be used on Starrett single column test frame. Use on Starrett dual column test frames only.

CIRCULAR PLATENS

ALUMINUM

- For compression testing applications on soft materials
- Surface is smooth
- Anodized finish
- Operating Temperatures -94° to 356°F (-70° to 180°C)



DIMENSIONS

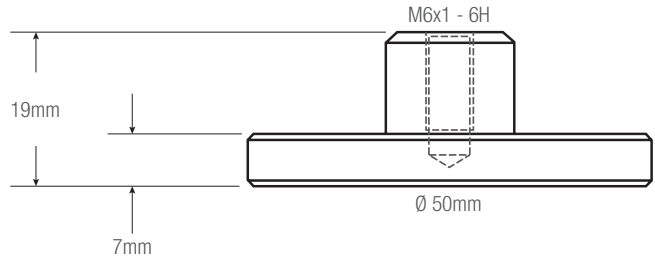

Circular Platens - Aluminum

Model No.	Load Capacity			Diameter ϕ		Weight (each)		Thread	Supply
	N	KGF	LBF	in	mm	lbs	kgs		
MLX-PLATE-TA-50	1,500	150	330	1.97	50	0.2	0.1	M6 x 1-6H	1

STEEL

- For compression testing applications on hard materials
- Surface is smooth
- Nickel plate finish
- Operating Temperatures -94° to 356°F (-70° to 180°C)



DIMENSIONS

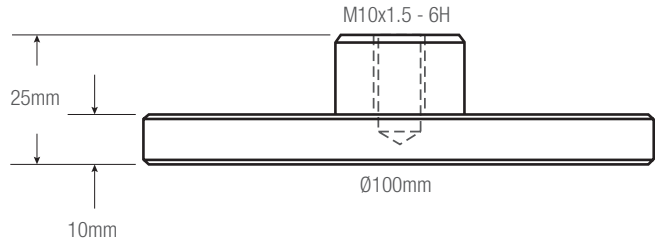

Circular Platens - Steel

Model No.	Load Capacity			Diameter ϕ		Weight (each)		Thread	Supply
	N	KGF	LBF	in	mm	lbs	kgs		
MLX-PLATE-TS-100	2,500	250	550	3.94	100	0.7	0.3	M10 x 1.5-6H	1

RECTANGULAR PLATENS

These general purpose compression platens are available in aluminum or steel. They mount to a 15.9mm clevis and are secured with a locking ring and grip pin.

ALUMINUM

- For compression testing applications on soft materials
- Surface has concentric grooves
- Anodized finish
- Operating Temperatures -94° to 356°F (-70° to 180°C)



Grip pins provided with each grip standard

Rectangular Platens - Aluminum									
Model No.	Load Capacity			Dimensions		Weight (each)		Clevis Type mm	Supply
	N	KGF	LBF	in	mm	lbs	kg		
PLATEN-36A-50-1	20,000	2,000	4,500	1.96 x 1.96	50 x 50	0.5	0.2	15.9	2
PLATEN-36A-100-1	20,000	2,000	4,500	3.9 x 3.9	100 x 100	1.3	0.6	15.9	2
PLATEN-36A-120-1	20,000	2,000	4,500	4.7 x 4.7	120 x 120	1.8	0.8	15.9	2
PLATEN-36A-150-1	20,000	2,000	4,500	5.9 x 5.9	150 x 150	2.9	1.3	15.9	2
PLATEN-36A-200-1	20,000	2,000	4,500	7.9 x 7.9	200 x 200	4.6	2.1	15.9	2
PLATEN-36A-250-1 ¹	20,000	2,000	4,500	9.8 x 9.8	250 x 250	7.5	3.4	15.9	2
PLATEN-36A-300-1 ¹	20,000	2,000	4,500	11.8 x 11.8	300 x 300	9.7	4.4	15.9	2
PLATEN-36A-400-1 ¹	20,000	2,000	4,500	15.7 x 15.7	400 x 400	19.2	8.7	15.9	2

Note¹: Platen cannot be used on Starrett single column test frame. Use on Starrett dual column test frames only.

DIMENSIONS

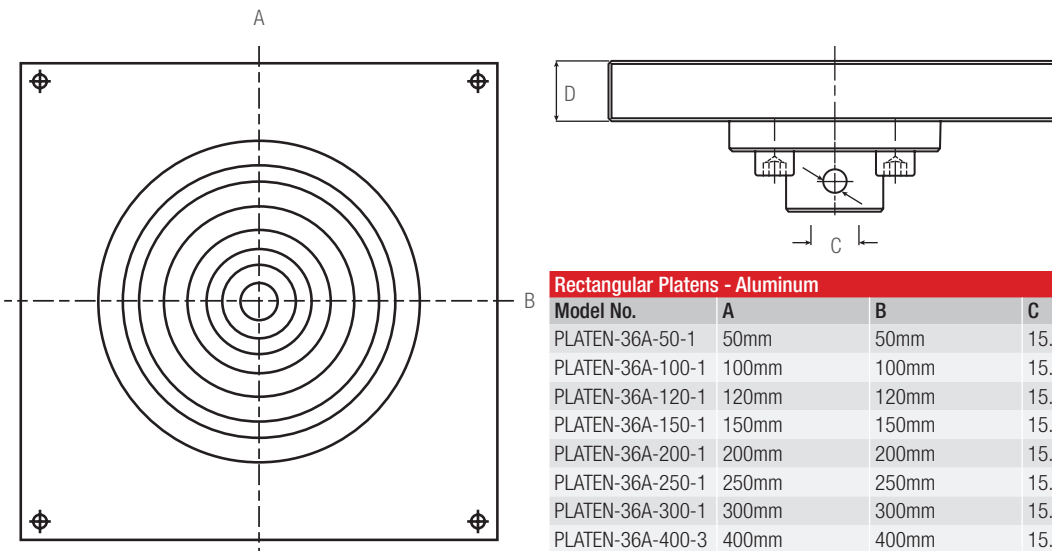

Rectangular Platens - Aluminum				
Model No.	A	B	C	D
PLATEN-36A-50-1	50mm	50mm	15.9mm	10mm
PLATEN-36A-100-1	100mm	100mm	15.9mm	20mm
PLATEN-36A-120-1	120mm	120mm	15.9mm	20mm
PLATEN-36A-150-1	150mm	150mm	15.9mm	20mm
PLATEN-36A-200-1	200mm	200mm	15.9mm	20mm
PLATEN-36A-250-1	250mm	250mm	15.9mm	20mm
PLATEN-36A-300-1	300mm	300mm	15.9mm	20mm
PLATEN-36A-400-3	400mm	400mm	15.9mm	20mm

RECTANGULAR PLATENS

STEEL

- For compression testing applications on hard materials 58 HRC
- Surface has concentric grooves
- Black Phosphate finish
- Operating Temperatures 0° to 350°C (32° to 662°F)



Rectangular Platens - Steel									
Model No.	Load Capacity			Dimensions		Weight (each)		Clevis Type mm	Supply
	N	KGF	LBF	in	mm	lbs	kgs		
PLATEN-36S-100-1	20,000	2,000	4,500	3.9 x 3.9	100 x 100	3.5	1.6	15.9	1
PLATEN-36S-196-1	20,000	2,000	4,500	7.7 x 7.7	196 x 196	14.6	6.6	15.9	1
PLATEN-36S-246-1 ¹	20,000	2,000	4,500	9.7 x 9.7	246 x 246	22.9	10.4	15.9	1
PLATEN-36S-296-1 ¹	20,000	2,000	4,500	11.7 x 11.7	296 x 296	30	13.6	15.9	1
PLATEN-36S-396-1 ¹	20,000	2,000	4,500	15.6 x 15.6	396 x 396	72.8	33	15.9	1
PLATEN-36S-100-3	50,000	5,000	11,000	3.9 x 3.9	100 x 100	3.5	1.6	31.8	1
PLATEN-36S-196-3	50,000	5,000	11,000	7.7 x 7.7	196 x 196	14.6	6.6	31.8	1
PLATEN-36S-246-3 ¹	50,000	5,000	11,000	9.7 x 9.7	246 x 246	22.9	10.4	31.8	1
PLATEN-36S-296-3 ¹	50,000	5,000	11,000	11.7 x 11.7	296 x 296	30	13.6	31.8	1
PLATEN-36S-396-3 ¹	50,000	5,000	11,000	15.6 x 15.6	396 x 396	72.8	33	31.8	1

Note¹: Platen cannot be used on Starrett single column test frame. Use on Starrett dual column test frames only.

DIMENSIONS

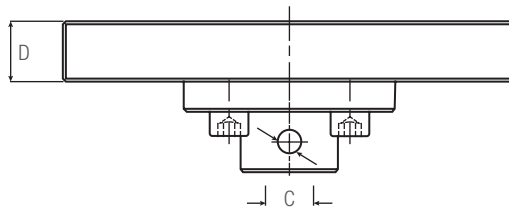
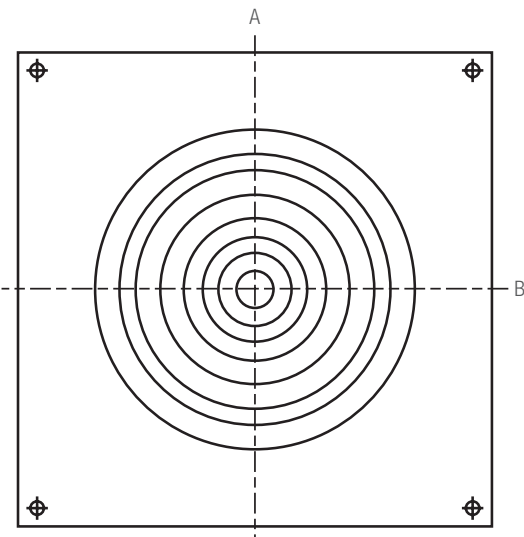

Rectangular Platens - Steel				
Model No.	A	B	C	D
PLATEN-36S-100-1	100mm	100mm	15.9mm	20mm
PLATEN-36S-196-1	196mm	196mm	15.9mm	20mm
PLATEN-36S-246-1	246mm	246mm	15.9mm	20mm
PLATEN-36S-296-1	296mm	296mm	15.9mm	20mm
PLATEN-36S-396-1	396mm	396mm	15.9mm	20mm
PLATEN-36S-100-3	100mm	100mm	31.8mm	20mm
PLATEN-36S-196-3	196mm	196mm	31.8mm	20mm
PLATEN-36S-246-3	246mm	246mm	31.8mm	20mm
PLATEN-36S-296-3	296mm	296mm	31.8mm	20mm
PLATEN-36S-396-3	396mm	396mm	31.8mm	20mm

RECTANGULAR PLATENS

PERFORATED PLATENS

These rectangular compression platens are ideal for testing foam. These platens have 6mm holes every 20mm that allow air to escape during compression. They mount to a 15.9mm clevis and are secured with a locking ring and grip pin.

ALUMINUM

- For compression testing applications on foam material
- Surface has 6mm holes every 20mm
- Anodized finish
- Operating Temperatures 32° to 356°F (0° to 180°C)

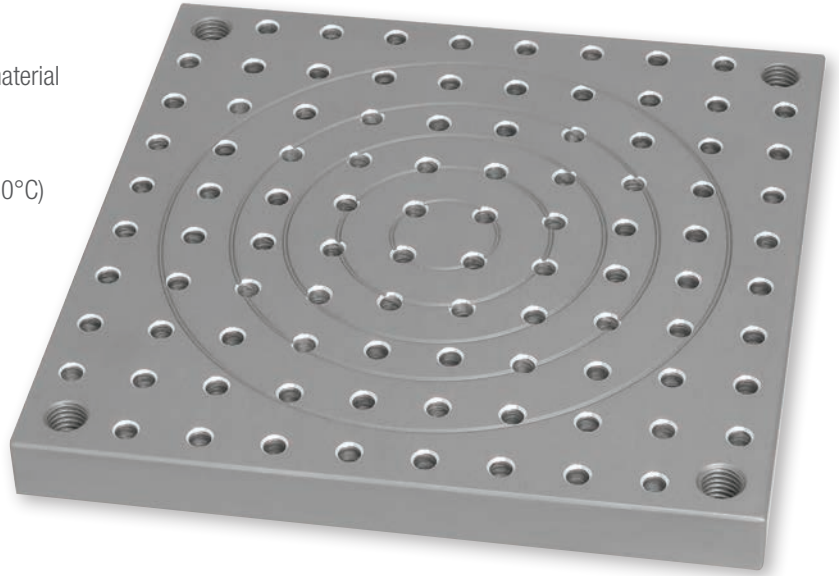

Rectangular Platens - Aluminum

Model No.	Load Capacity			Dimensions		Weight (each)		Clevis Type mm	Supply
	N	KGF	LBF	in	mm	lbs	kgs		
PLATEN-36LA-150-1	20,000	2,000	4,500	5.9 x 5.9	150 x 150	2.5	1.1	15.9	1
PLATEN-36LA-200-1	20,000	2,000	4,500	7.9 x 7.9	200 x 200	4.4	2	15.9	1
PLATEN-36LA-400-1 ¹	20,000	2,000	4,500	15.8 x 15.8	400 x 400	18.1	8.2	15.9	1

Note¹: Platen cannot be used on Starrett single column test frame. Use on Starrett dual column test frames only.

DIMENSIONS

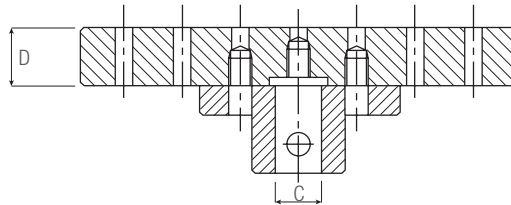
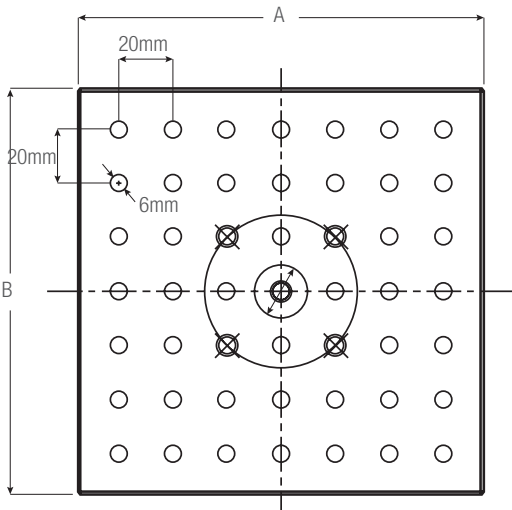

Rectangular Platens - Aluminum

Model No.	A	B	C	D
PLATEN-36LA-150-1	150mm	150mm	15.9mm	20mm
PLATEN-36LA-200-1	200mm	200mm	15.9mm	20mm
PLATEN-36LA-400-1	400mm	400mm	15.9mm	20mm

SELF-ALIGNMENT PLATENS

These specialty circular platens are ideal for compression samples that may not be parallel to the test datum. These platens are self-aligning where the platen adjusts to the sample's surfaces to ensure parallel and perpendicular axial loading. These platen may be set in a fixed position if required. They mount to a 15.9mm clevis and are secured with a locking ring and grip pin.

STEEL

- For compression testing applications where sample parallelism is a problem
- Self-aligning or fixed positioning
- Surface has smooth finished
- Phosphate coating
- Operating Temperatures -0° to 280°C (32° to 536°F)



Self-Aligning Circular Platens- Steel									
Model No.	Load Capacity			Diameter ø		Weight (each)		Clevis Type mm	Supply
	N	KGF	LBF	in	mm	lbs	kgs		
PLATEN-223S-56-1	20,000	2,000	4,500	2.2	56	3	1.3	15.9	1
PLATEN-223S-96-1	20,000	2,000	4,500	3.8	96	3.3	1.5	15.9	1
PLATEN-223S-116-1	20,000	2,000	4,500	4.6	116	4	1.8	15.9	1
PLATEN-223S-156-1	20,000	2,000	4,500	6.2	156	6.5	2.8	15.9	1
PLATEN-223S-246S-1	20,000	2,000	4,500	9.6	246	11	5	15.9	1

The maximum load for the standard 15.9mm is 20kN.

DIMENSIONS

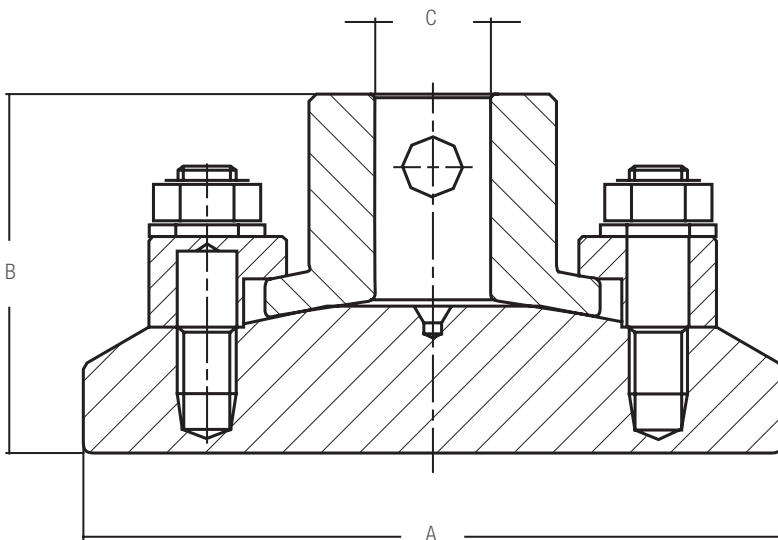

Self-Aligning Circular Platens - Steel			
Model No.	A	B	C
PLATEN-223S-56-1	56mm	49mm	15.9mm
PLATEN-223S-96-1	96mm	49mm	15.9mm
PLATEN-223S-116-1	116mm	49mm	15.9mm
PLATEN-223S-156-1	156mm	49mm	15.9mm
PLATEN-223S-246-1	246mm	49mm	15.9mm

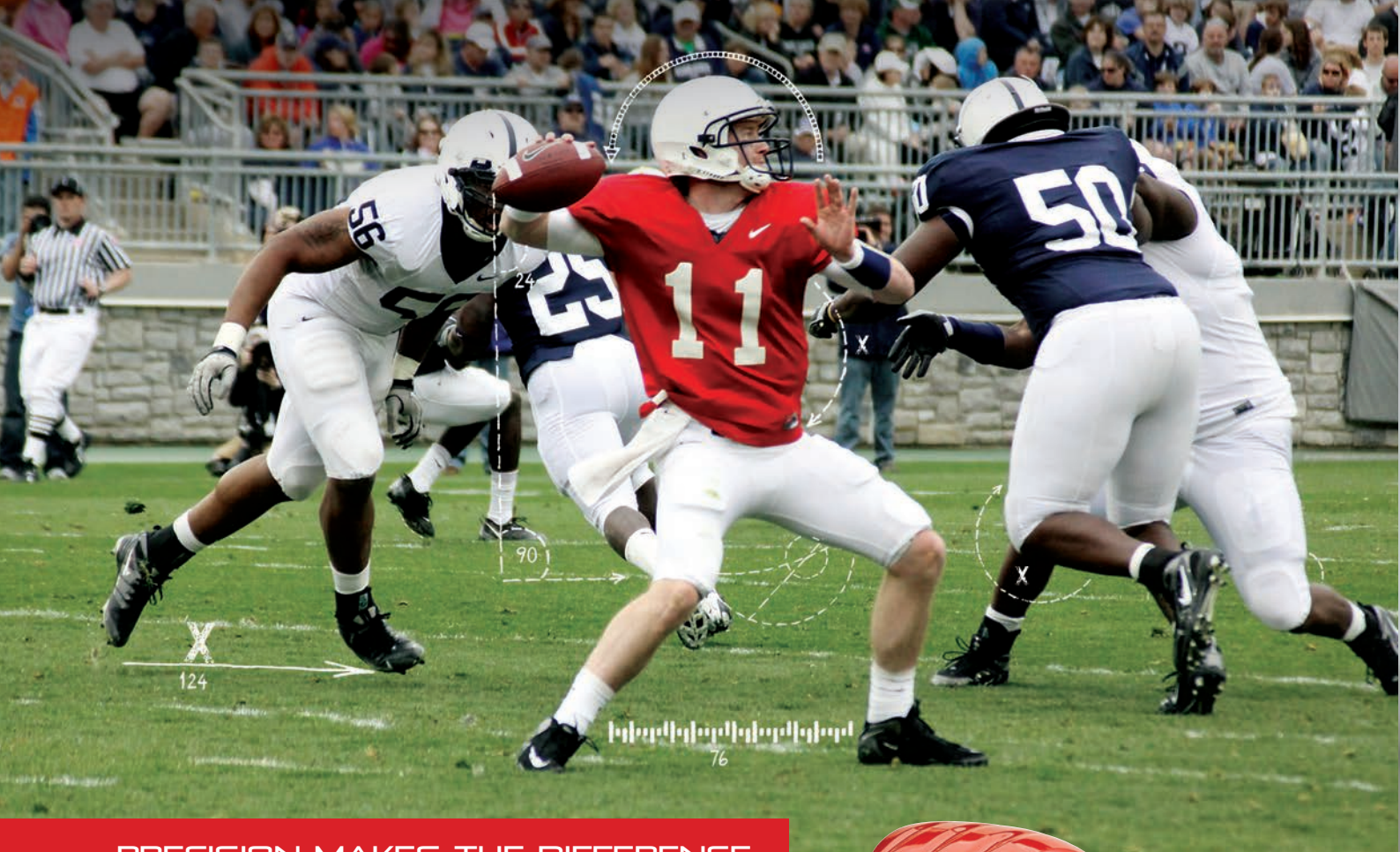

PRECISION MAKES THE DIFFERENCE

GOES THE DISTANCE.

Three major product lines to meet our customer's needs with performance and quality.



Starrett®

(978) 249-3551 • starrett.com

Follow us!





ECCENTRIC ROLLERS

ROLLER FIXTURES

Eccentric roller fixtures are self-tightening and ideal for flat samples. Starrett offers a variety of different roller fixtures with various diameters and sample thicknesses.

Eccentric rollers can be supplied with smooth, serrated and rubber surfaces.

Starrett can assist you in selecting the proper roller fixture for your sample.

OPERATION

Eccentric roller fixtures feature a design that helps ensure proper sample alignment and that promotes a correct sample break between the upper and lower test fixture. These fixtures feature an eccentric roller that holds the sample firmly in place during tensile movement.

Eccentric rollers are easy to use. The roller is held in place with a spring mechanism that lets you open and close the roller onto the sample under test. There are different sizes for different sample thicknesses. Rollers typically have a serrated face, though you may also use rubber-coated and smooth faced rollers.

TESTING STANDARDS

There are a variety of materials that can utilize eccentric roller samples. Contact your Starrett representative for more information about your specific testing method and the available test fixtures.

Model No.	Load Capacity			Roller Diameter	Clamping Width	Type
	N	KGF	LBF			
Eccentric Roller Grip - Single Roller						
ROLLER-7-1A-1	1,000	100	225	25mm \emptyset	50mm	Clevis
ROLLER-7-1RA-A	1,000	100	225	25mm \emptyset	50mm	Clevis
ROLLER-7-5A-1	5,000	500	1,100	30mm \emptyset	50mm	Clevis
ROLLER-7-5A-100	5,000	500	1,100	30mm \emptyset	100mm	Clevis
ROLLER-7-10S-1	10k	1,000	2,200	50mm \emptyset	60mm	Clevis
Eccentric Roller Grip - Dual Opposing Rollers						
ROLLER-766-5S-1	5,000	500	1,100	30mm \emptyset	30mm	Clevis



ROLLER FIXTURES

Eccentric roller fixtures are self-tightening and ideal for flat samples. Starrett offers a variety of different roller fixtures with various diameters and sample thicknesses.

Eccentric rollers can be supplied with smooth, serrated and rubber surfaces.

Starrett can assist you in selecting the proper roller fixture for your sample.

ROLLER 1kN

ALUMINUM

- For general-purpose tensile testing applications
- Use on soft samples including rubber, foils, paper and plastic film
- Anodized finish
- Operating Temperatures 32° to 266°F (0° to 130°C)



ECCENTRIC ROLLERS

Model No.	Load Capacity			Base Plate Material	Jaw Face Type	Sample Thickness (max)		Sample Width (Max)		Weight (each)		Clevis Type mm	Supply
	N	KGF	LBF			in	mm	in	mm	lbs	kgs		
ROLLER-7-1A-1	1,000	100	225	Aluminum	Serrated	0.28	7	1.97	50	1.1	0.5	15.9	2
ROLLER-7-1RA-1	1,000	100	225	Rubber	Smooth	0.25	7	1.97	50	1.1	0.5	15.9	2

DIMENSIONS

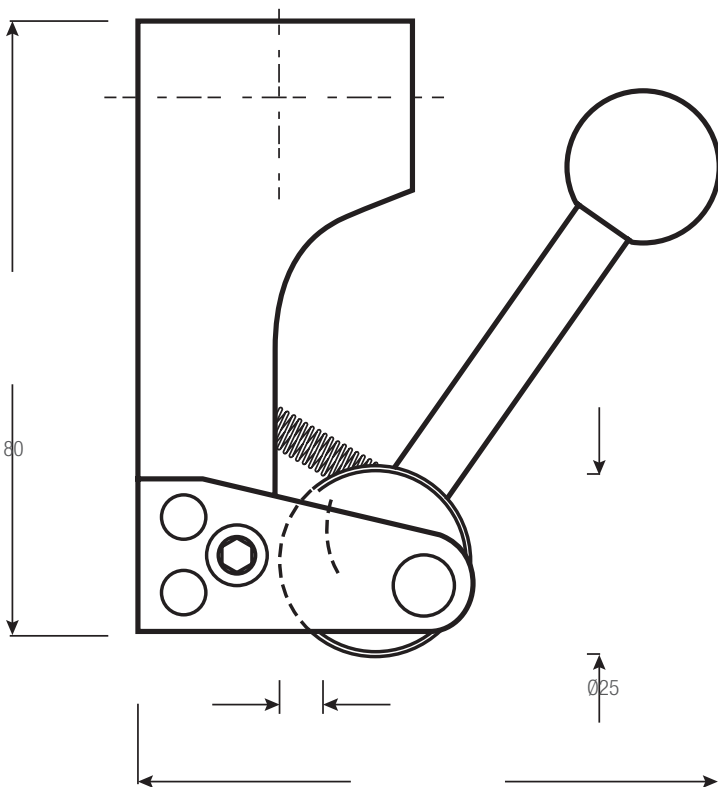

0-7

76.2

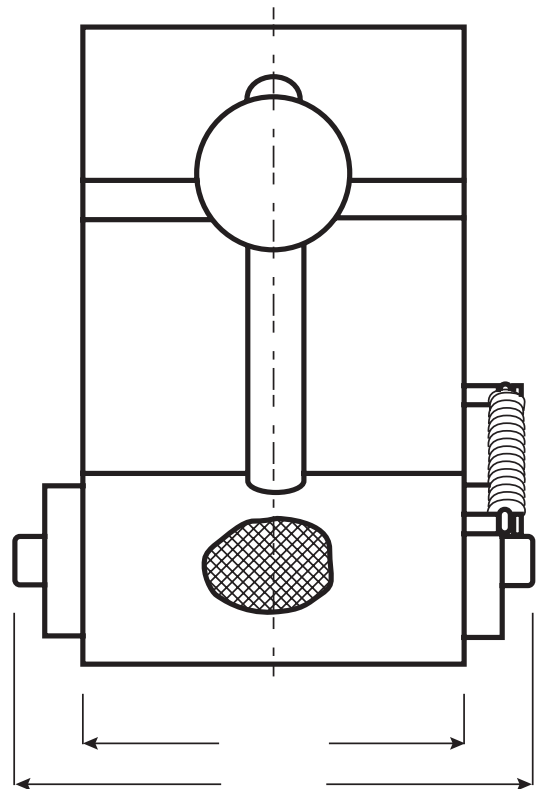

50

68

ROLLER FIXTURES

ROLLER 5kN

ALUMINUM

- For general-purpose tensile testing applications
- Use on soft samples including rubber, foils, paper and plastic film
- Anodized finish
- Operating Temperatures 32° to 266°F (0° to 130°C)



Shown: ROLLER-7-5A-100

Eccentric Roller Grips

Model No.	Load Capacity			Jaw Face Type	Sample Thickness (max)		Sample Width (Max)		Weight (each)		Clevis Type	Supply
	N	KGF	LBF		in	mm	in	mm	lbs	kgs		
ROLLER-7-5A-1	5,000	500	1,100	Serrated	1.97	50	0.28	7	1.6	0.7	15.9	2
ROLLER-7-5A-100	5,000	500	1,100	Serrated	3.94	100	0.28	7	7.5	3.4	15.9	2

DIMENSIONS

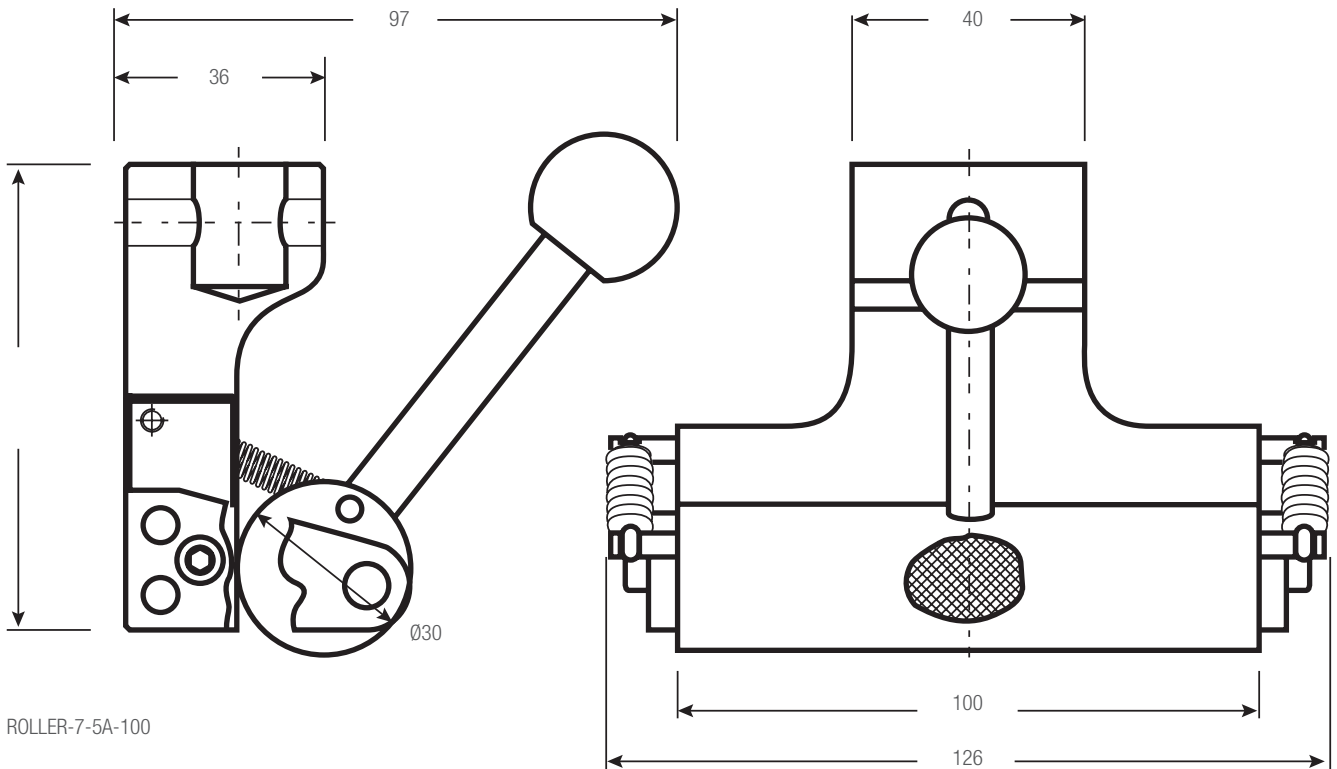

ROLLER FIXTURES

ROLLER 10kN

ALUMINUM

- For general-purpose tensile testing applications
- Serrated roller
- Anodized finish
- Operating Temperatures 32° to 266°F (0° to 130°C)

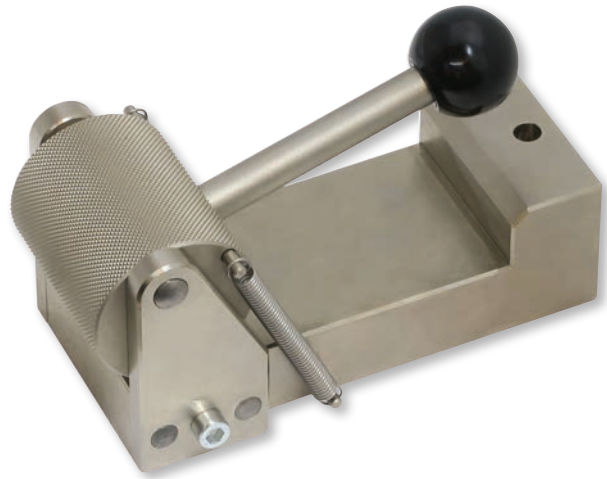

Eccentric Roller Grips													
Model No.	Load Capacity			Jaw Face Type	Sample Thickness (max)		Sample Width (Max)		Weight (each)		Clevis Type mm	Supply	
	N	KGF	LBF		in	mm	in	mm	lbs	kgs			
ROLLER-7-10S-1	10k	1000	2200	Serrated	0.31	8	2.36	60	3.3	1.5	15.9	2	

DIMENSIONS

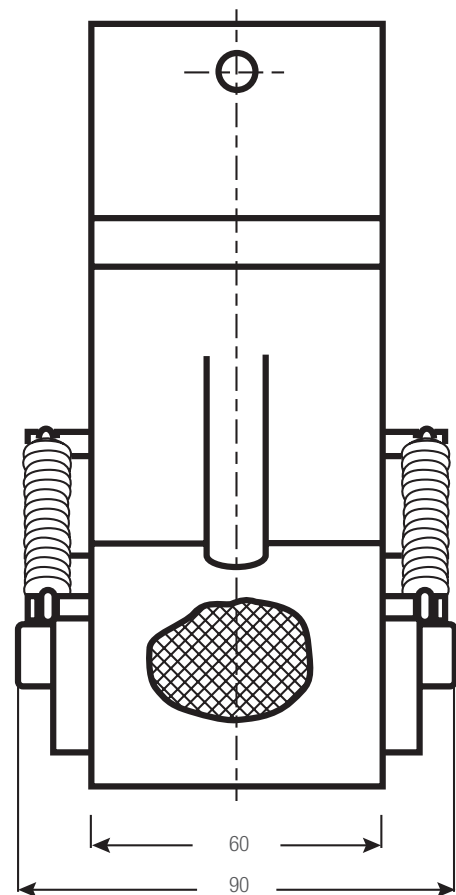
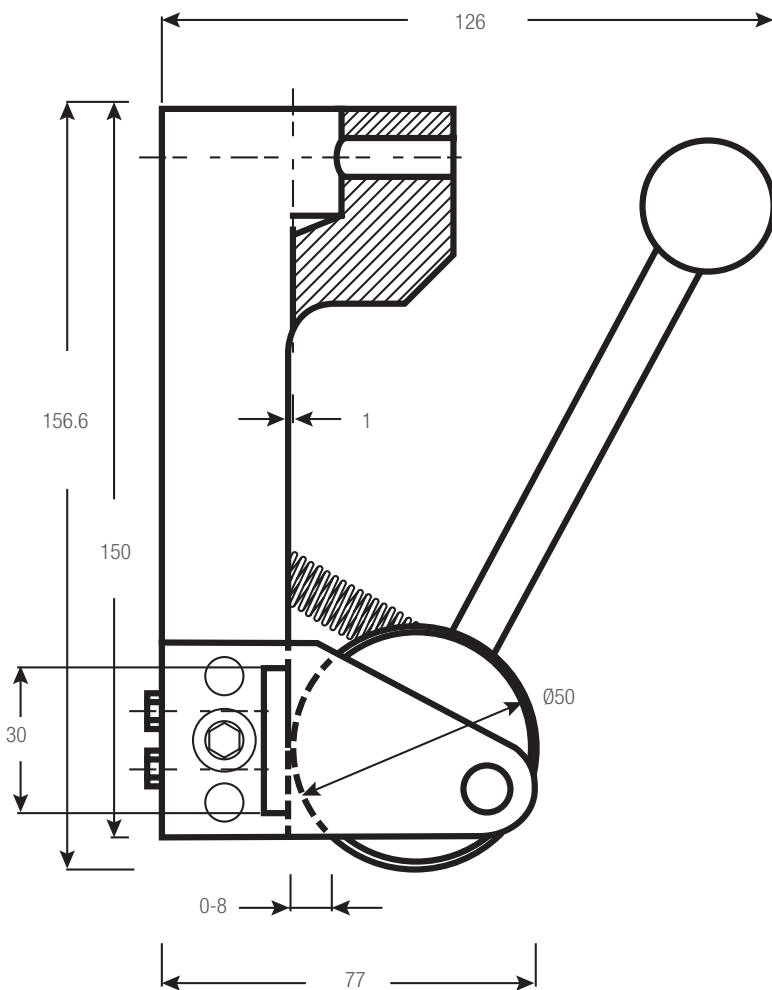

ROLLER FIXTURES

ROLLER 5kN

STEEL, NICKEL-PLATED

- For general-purpose tensile testing applications
- Dual-action rollers
- 30mm diameter rollers
- Operating Temperatures 32° to 266°F (0° to 130°C)



Eccentric Roller Grips

Model No.	Load Capacity			Jaw Face Type	Sample Thickness (max)		Sample Width (max)		Weight (each)		Clevis Type	Supply
	N	KGF	LBF		in	mm	in	mm	lbs	kgs		
ROLLER-766-5S-1	5000	500	1100	Serrated	0.29	15	1.2	30	3.1	1.4	15.9	2

DIMENSIONS

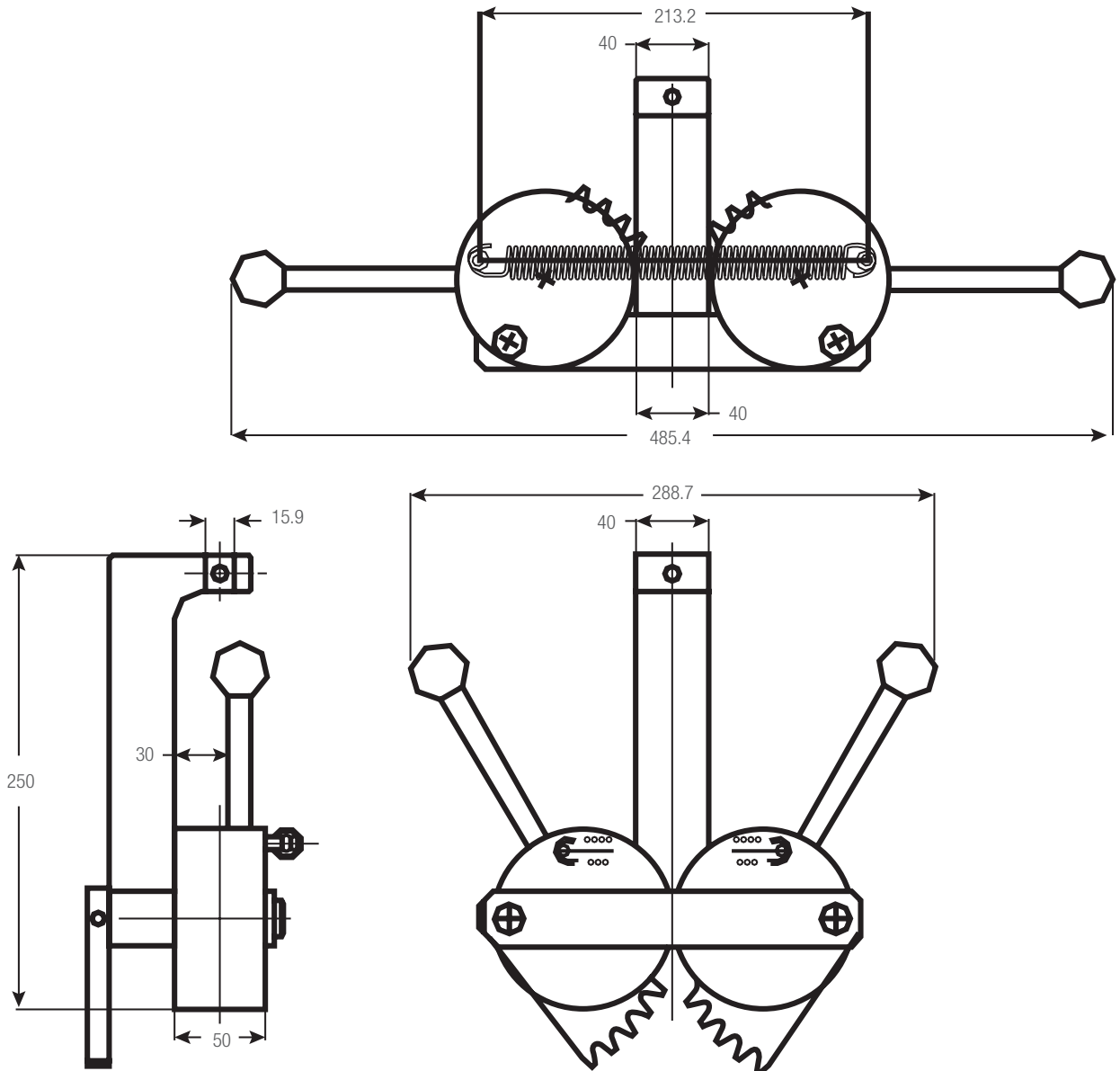



WISE-ACTION FIXTURES

VISE-ACTION FIXTURES

Starrett vise-action test fixtures tighten manually. Starrett offers a variety of different vise-action fixtures with various clamping surfaces and jaw openings.

Vise-action fixtures can be supplied with smooth, serrated diamond and rubber surfaces.

Starrett can assist you in selecting the proper vise-action fixture for your sample.

OPERATION

Vise-action test fixtures are designed for easy sample loading and alignment. Using a screw mechanism on the test fixture, you apply force against the sample being tested in order to secure the sample in place.

Starrett offers a variety of vise-action test fixtures with different capacities. We also offer a wide assortment of grip faces including smooth, serrated, v-notch, diamond and rubber.

TESTING STANDARDS

There are a variety of testing standards that can make use of a vise-action test fixture. Contact your Starrett representative for more information about your specific testing method and the available test fixtures.



Vise-Action Fixtures						
Model No.	Load Capacity			Jaw Face	Jaw Opening (Max) mm	Clamping Surface mm
	N	KGF	LBF			
WISE-205K-10-S	20	2	4	Smooth	3.4	10 x 10
WISE-205X-10-S	20	2	4	Smooth	3.4	10 x 10
WISE-341-6-P	100	10	22	Serrated	4	6 x 5
WISE-341-6-PX	100	10	22	Serrated	4	6 x 5
WISE-341-10-P	100	10	22	Serrated	4	10 x 15
WISE-341-10-PX	100	10	22	Serrated	4	10 x 15
WISE-140K	100	10	22	Serrated	8	10 x 15
WISE-227A-M5	100	10	22	No Jaws	8	Jaw Dependant
WISE-227S-46	100	10	22	No Jaws	46	Jaw Dependant
WISE-466-10	500	50	110	Smooth	33.1	10
WISE-56KA-1	1,000	100	225	No Jaws	8	Jaw Dependant
WISE-56GA-1	1,000	100	225	No Jaws	15	Jaw Dependant
WISE-56GHA-1	1,000	100	225	No Jaws	15	Jaw Dependant
WISE-240KA-1	2,500	250	550	No Jaws	10	Jaw Dependant
WISE-240KA-20-1	1,000	100	225	No Jaws	20	Jaw Dependant
WISE-240KA-30-1	1,000	100	225	No Jaws	30	Jaw Dependant
WISE-240KA-50-1	1,000	100	225	No Jaws	50	Jaw Dependant
WISE-470-25P	2,000	200	450	Serrated	10	25 x 25
WISE-9	2,500	250	550	No Jaws	6	Jaw Dependant
WISE-240G	5kN	500	1,124	No Jaws	24	Jaw Dependant
WISE-240G-S50	5kN	500	1,124	No Jaws	50	Jaw Dependant
WISE-240G-S100	5kN	500	1,124	No Jaws	100	Jaw Dependant
WISE-154A-10-1	10K	1,000	2,200	No Jaws	Jaw Dependant	Jaw Dependant
WISE-154S-20-1	20K	2,000	4,400	No Jaws	Jaw Dependant	Jaw Dependant
WISE-90-50	50K	5,000	11,124	No Jaws	Jaw Dependant	Jaw Dependant

WISE-ACTION FIXTURES

Vise-action test fixtures secure the sample with a pinching force. Vise-action test fixtures let you manually tighten the jaws to the sample. A variety of vise-action test fixtures are available and suited for a wide assortment of samples and applications.

Many vise-action test fixtures may be supplied with pneumatic actuators. These are ideal for high-volume testing applications offering a quick open-release capability. Please see the Pneumatic specification sheet for more information.

205K ALUMINUM, ANODIZED

- For general-purpose tensile testing applications
- Available as chain attachment or direct connect model
- Operating Temperatures 32° to 356°F (0° to 180°C)



DIMENSIONS

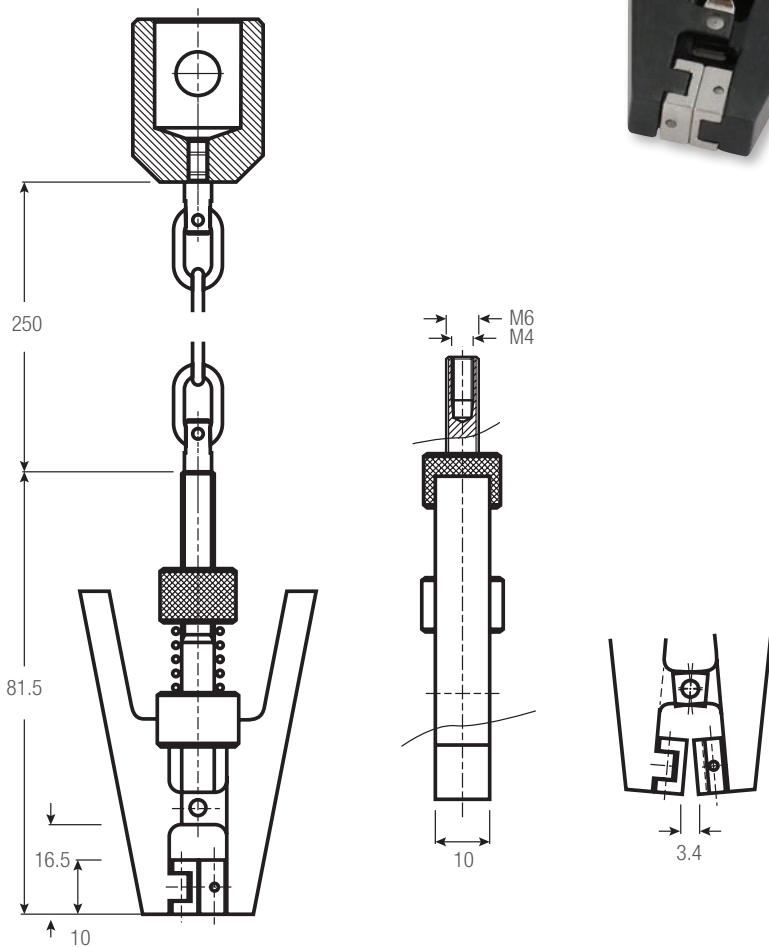

VISE-ACTION FIXTURES

Vise-Action Fixtures													
Model No.	Load Capacity			Chain Attachment	Jaw Face	Jaw Opening (Max)		Clamping Surface		Weight (each)		Clevis Type	Supply
	N	KGF	LBF			in	mm	in	mm	lbs	kgs		
VISE-205K-10-S	20	2	4	Yes	Smooth	0.13	3.4	0.4 x 0.4	10 x 10	1.3	0.6	15.9	1
VISE-205X-10-S	20	2	4	No	Smooth	0.13	3.4	0.4 x 0.4	10 x 10	1.1	0.5	15.9	1

VISE-ACTION FIXTURES

341

STEEL, PHOSPHATE COATED

- For general-purpose tensile testing applications
- Ideal for pull-off testing on electrical components
- With our without chain attachment
- Operating Temperatures 32° to 266°F (0° to 130°C)



DIMENSIONS

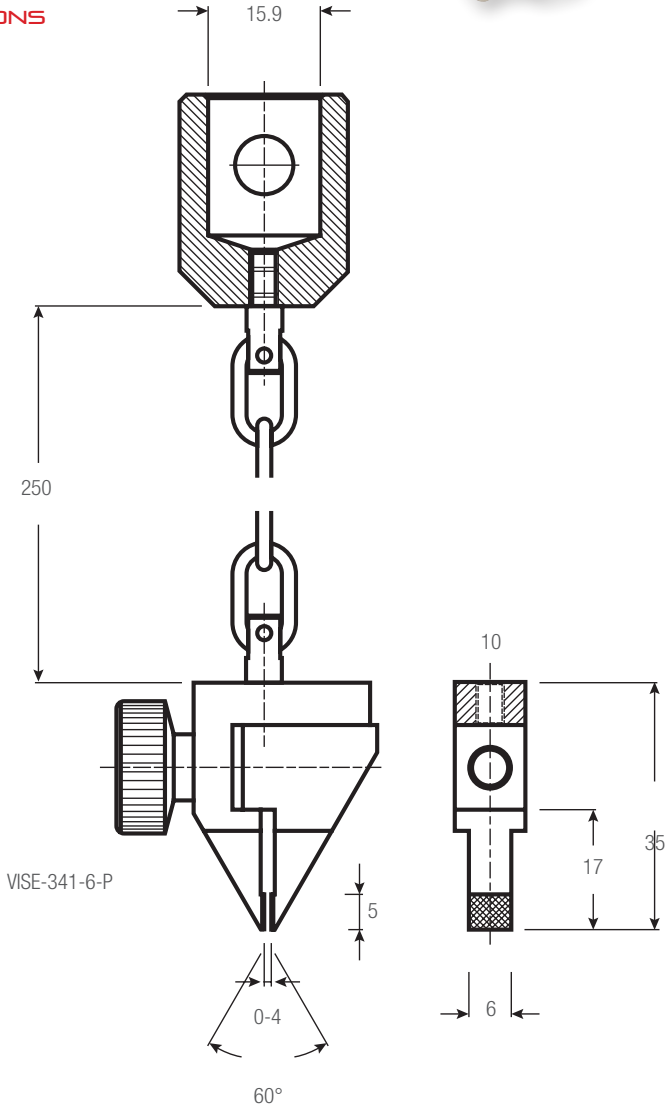

Vise-Action Fixtures													
Model No.	Load Capacity			Chain Attachment	Jaw Face	Jaw Opening (Max)		Clamping Surface		Weight (each)		Clevis Type	Supply
	N	KGF	LBF			in	mm	in	mm	lbs	kgs		
WISE-341-6-P	100	10	22	Yes	Serrated	0.16	4	0.24 x 0.2	6 x 5	0.2	0.1	15.9	1
WISE-341-6-PX	100	10	22	No	Serrated	0.16	4	0.24 x 0.2	6 x 5	0.2	0.1	15.9	1
WISE-341-10-P	100	10	22	Yes	Serrated	0.16	4	0.4 x 0.6	10 x 15	0.2	0.1	15.9	1
WISE-341-10-PX	100	10	22	No	Serrated	0.16	4	0.4 x 0.6	10 x 15	0.2	0.1	15.9	1

WISE-ACTION FIXTURES

140

ALUMINUM, ANODIZED

- For general-purpose tensile testing applications
- Dual-action tightening from both sides
- Operating Temperatures 32° to 266°F (0° to 130°C)

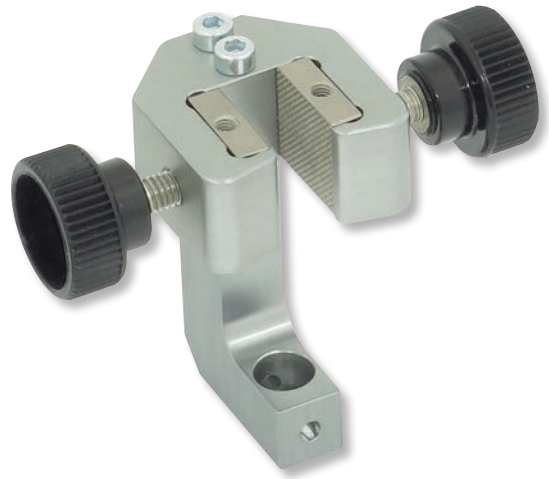

Vise-Action Fixtures													
Model No.	Load Capacity			Jaw Face	Jaw Opening (Max)		Clamping Surface		Weight (each)		Clevis Type	Supply	
	N	KGF	LBF		in	mm	in	mm	lbs	kgs			
WISE-140K-15P	100	10	22	Serrated	0.3	8	0.6 x 0.6	15 x 15	0.2	0.1	15.9	1	

DIMENSIONS

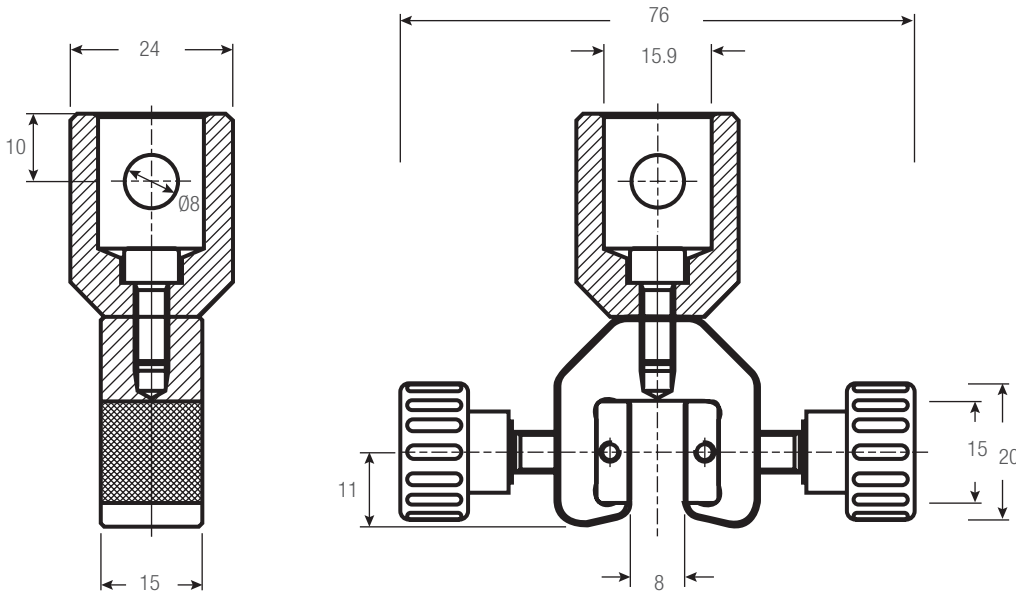

140 JAW SETS

STEEL, HARDENED

- Supplied four (4) jaws per set
- Operating Temperatures 32° to 266°F (0° to 130°C)

Jaw Sets					
Model No.	Jaw Face	Jaw Opening (Max)		Clamping Surface	
		in	mm	in	mm
JAW140-B	Smooth	0.3	8	0.6 x 0.6	15 x 15
JAW140-BR	Rubber	0.2	6	0.6 x 0.6	15 x 15
JAW140-PY	Serrated	0.3	8	0.6 x 0.6	15 x 15

SMOOTH JAW

- Suitable for own further treatments
- Steel-blanks without coating

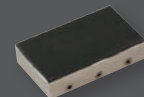

RUBBER-COATED JAW

- 1 mm rubber coating (NBR)
- Nickel-plated

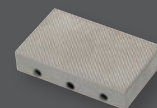

SERRATED JAW

- Pyramids 1.2 x 45°
- Hardened steel 58HRC
- Nickel-plated

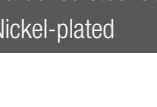

VISE-ACTION FIXTURES

227

ALUMINUM, ANODIZED

- For general-purpose tensile testing applications
- Dual-action tightening from both sides
- Order required jaw set separately
- Operating Temperatures 32° to 266°F (0° to 130°C)



Vise-Action Fixtures												
Model No.	Load Capacity			Jaw Face	Jaw Opening (Max)		Clamping Surface		Weight (each)		Clevis Type mm	Supply
	N	KGF	LBF		mm	in	in	mm	lbs	kgs		
WISE-227A-M5	100	10	22	No Jaws	8	0.3	Jaw Dependent		0.2	0.1	15.9	2
WISE-227S-46	100	10	22	No Jaws	46	1.8	Jaw Dependent		0.2	0.1	15.9	2

DIMENSIONS

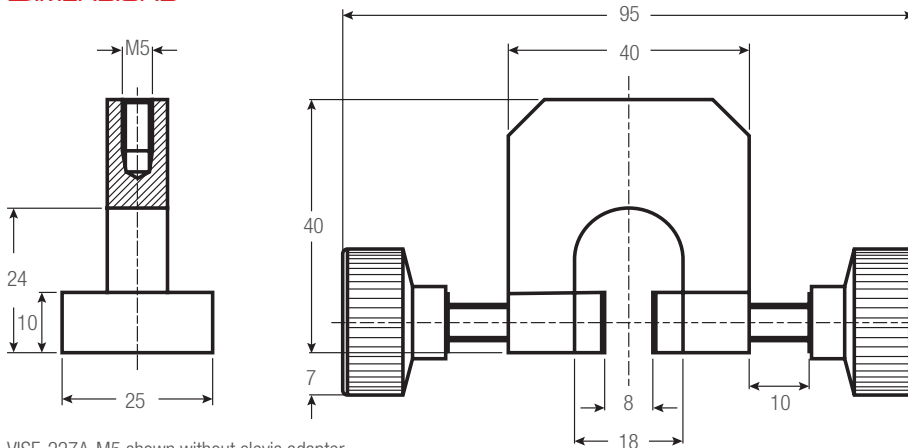

WISE-227A-M5 shown without clevis adapter

227 JAW SETS

STEEL, HARDENED

- Supplied four (4) jaws per set
- Operating Temperatures 32° to 266°F (0° to 130°C)

Jaw Sets							
Model No.	Jaw Face	Jaw Opening (Max)				Clamping Surface	
		WISE-227-08		WISE-227-46		in	mm
JAW227-B25	Smooth	0.3	8	1.8	46	0.4 x 0.98	10 x 25
JAW227-BR25	Rubber	0.2	6	1.7	44	0.4 x 0.98	10 x 25
JAW227-PY25	Serrated	0.3	8	1.8	46	0.4 x 0.98	10 x 25
JAW227-WV25	Wave	0.3	8	1.8	46	0.4 x 0.98	10 x 25
JAW227-D25	Diamond	0.3	8	1.8	46	0.4 x 0.98	10 x 25
JAW227-B50	Smooth	0.2	6	1.7	44	0.4 x 1.97	10 x 50
JAW227-BR50	Rubber	0.16	4	1.65	42	0.4 x 1.97	10 x 50
JAW227-PY50	Serrated	0.2	6	1.7	44	0.4 x 1.97	10 x 50
JAW227-D50	Diamond	0.2	6	1.7	44	0.4 x 1.97	10 x 50
JAW227-B100	Smooth	0.2	6	1.7	44	0.4 x 3.94	10 x 100
JAW227-BR100	Rubber	0.16	4	1.65	42	0.4 x 3.94	10 x 100
JAW227-PY100	Serrated	0.2	6	1.7	44	0.4 x 3.94	10 x 100
JAW227-D100	Diamond	0.2	6	1.7	44	0.4 x 3.94	10 x 100

SMOOTH JAW

- Suitable for own further treatments
- Steel-blanks without coating
- Rubber-Coated Jaw
- 1mm rubber coating (NBR)
- Nickel-plated

SERRATED JAW

- Pyramids 1.2 x 45°
- Hardened steel 58HRC
- Nickel-plate

WAVE JAW

- For flexible materials
- Wave 5mm
- Hardened steel 58HRC
- Nickel-plated

DIAMOND-COATED JAW

- Clamping surface coated with synthetic diamonds
- Nickel-plated

VISE-ACTION FIXTURES

466

ALUMINUM, ANODIZED

- For general-purpose tensile testing applications
- Thumbscrew operation
- Operating Temperatures -94° to 536°F (-70° to 280°C)

DIMENSIONS

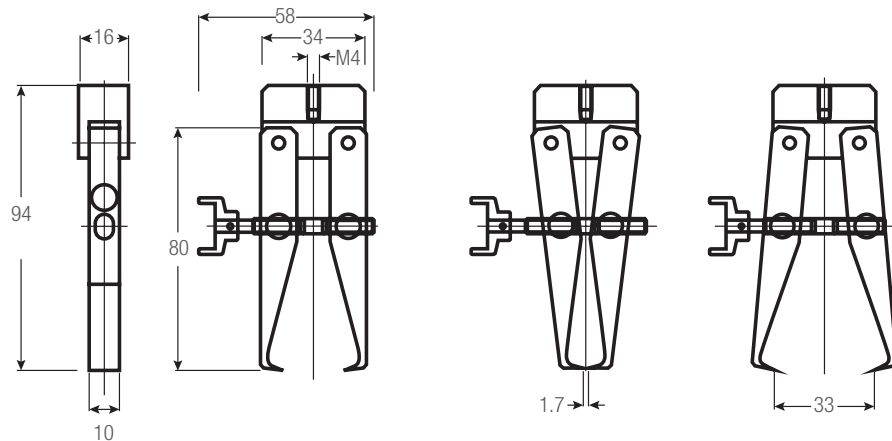

VISE-ACTION FIXTURES

Vise-Action Fixtures													
Model No.	Load Capacity			Jaw Face	Jaw Opening (Max)		Clamping Surface		Weight (each)		Clevis Type	Supply	
	N	KGF	LBF		in	mm	in	mm	lbs	kgs			
WISE-466-10	500	50	110	Smooth	1.3	33.1	0.39	10	0.4	0.18	15.9	1	

470

ALUMINUM, ANODIZED

- For general-purpose tensile testing applications
- Fixed jaw faces
- Operating Temperatures 32° to 356°F (0° to 180°C)

DIMENSIONS

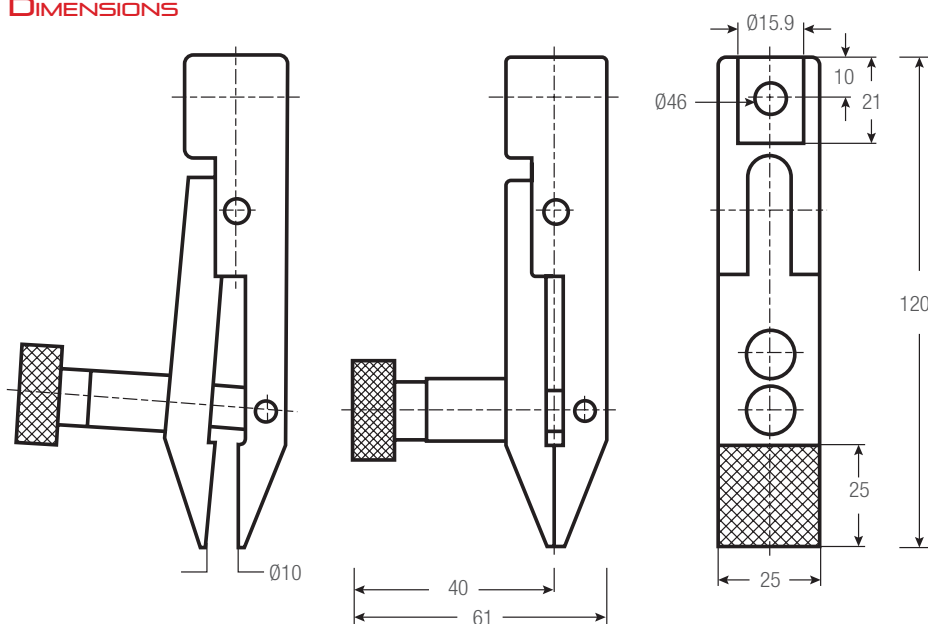

Vise-Action Fixtures													
Model No.	Load Capacity			Jaw Face	Jaw Opening (Max)		Clamping Surface		Weight (each)		Clevis Type	Supply	
	N	KGF	LBF		in	mm	in	mm	lbs	kgs			
WISE-470-25P	2,000	200	450	Serrated	0.4	10	1 x 1	25 x 25	1.1	0.5	15.9	1	

VISE-ACTION FIXTURES

56K

ALUMINUM, ANODIZED

- For general-purpose tensile testing applications
- Dual-action tightening from both sides
- Order required jaw set separately
- Operating Temperatures 32° to 356°F (0° to 180°C)

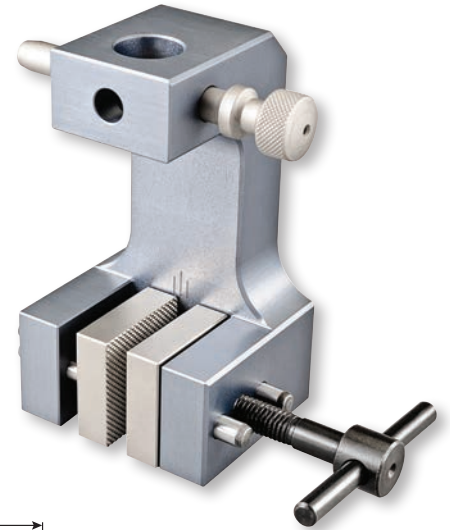

DIMENSIONS

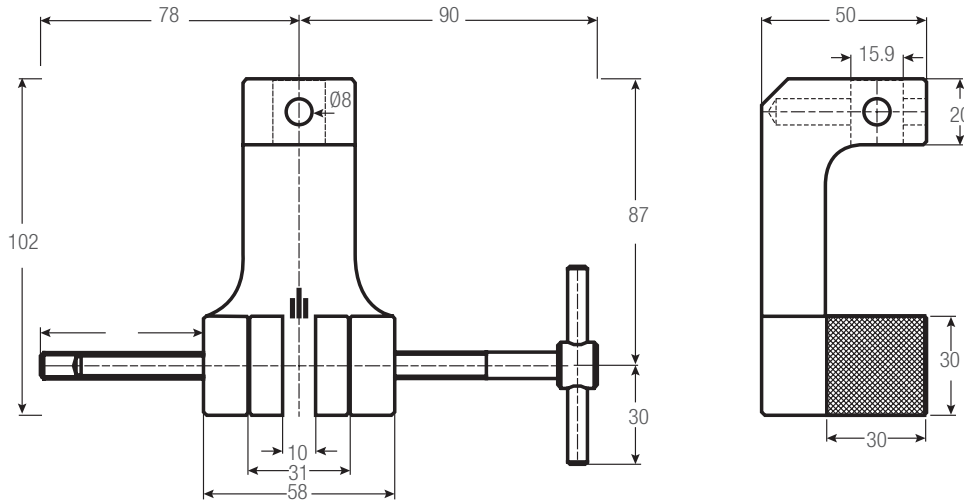

Vise-Action Fixtures

Model No.	Load Capacity			Jaw Face	Jaw Opening (Max)		Clamping Surface		Weight (each)		Clevis Type	Supply
	N	KGF	LBF		in	mm	in	mm	lbs	kgs		
WISE-56KA-1	1,000	100	225	No Jaws	0.3	8	Jaw Dependent		0.9	0.4	15.9	2

WISE-ACTION FIXTURES

56K JAW SETS

STEEL, HARDENED

- Supplied four (4) jaws per set
- Operating Temperatures 32° to 266°F (0° to 130°C)

Jaw Sets					
Model No.	Jaw Face	Jaw Opening (Max)		Clamping Surface	
		in	mm	in	mm
JAW56K-B30	Smooth	0.4	10	1.18 x 1.18	30 x 30
JAW56K-BR30	Rubber	0.2	8	1.18 x 1.18	30 x 30
JAW56K-PY30	Serrated	0.4	10	1.18 x 1.18	30 x 30
JAW56K-V2	V-Notch	0.08-0.4ø	2-10ø	1.18 x 1.18	30 x 30
JAW56K-V3	V-Notch	0.12-0.4ø	3-10ø	1.18 x 1.18	30 x 30
JAW56K-WV30	Wave	0.4	10	1.18 x 1.18	30 x 30
JAW56K-D30	Diamond	0.4	10	1.18 x 1.18	30 x 30

OPTIONAL CARRIER AND CARRIER SETS

STEEL, HARDENED

- Supplied four (4) jaws per set
- Operating Temperatures 32° to 266°F (0° to 130°C)
- Quick change jaw sets
- Requires both CARRIER-56K and CAR56K

Carrier Sets							
Model No.	Material	Face	Jaw Dimensions (h x w)		Opening Width (h x w)		Supply (each)
			in	mm	in	mm	
CARRIER-56K	Steel	-	-	-	-	-	4
CAR56K-B36	Steel	Smooth	1.18 x 1.18	30 x 30	0 - 0.3	0 - 8	4
CAR56K-BR36	Steel	Rubber	1.18 x 1.18	30 x 30	0 - 0.2	0 - 6	4
CAR56K-D36	Steel	Diamond	1.18 x 1.18	30 x 30	0 - 0.3	0 - 8	4
CAR56K-PY36	Steel	Serrated	1.18 x 1.18	30 x 30	0 - 0.3	0 - 8	4

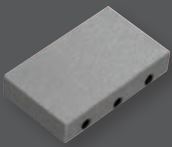

SMOOTH JAW

- Suitable for own further treatments
- Steel-blanks without coating

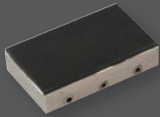

RUBBER-COATED JAW

- 1mm rubber coating (NBR)
- Nickel-plated

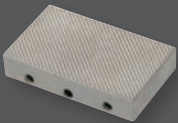

SERRATED JAW

- Pyramids 1.2 x 45°
- Hardened steel 58HRC
- Nickel-plated

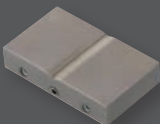

V-NOTCH JAW

- For all kinds of round samples
- Tooth pitch 1.2mm
- Hardened steel
- Nickel-plated

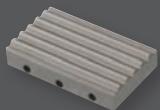

WAVE JAW

- For flexible materials
- Wave 5mm
- Hardened steel 58HRC
- Nickel-plated

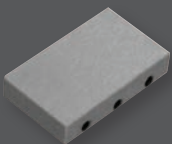

DIAMOND-COATED JAW

- Clamping surface coated with synthetic diamonds
- D91 (170/200 mesh)
- Nickel-plated

VISE-ACTION FIXTURES

56G

ALUMINUM, ANODIZED

- For general-purpose tensile testing applications
- Dual-action tightening from both sides
- Order required jaw set separately
- Operating Temperatures 32° to 356°F (0° to 180°C)

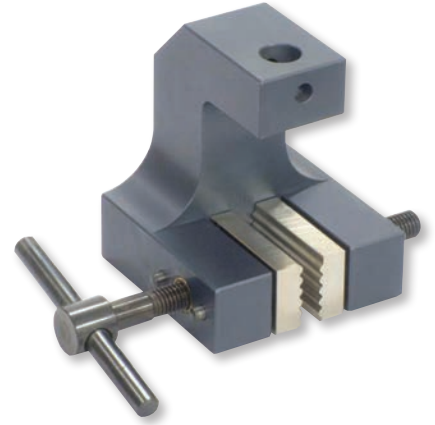

Vise-Action Fixtures													
Model No.	Load Capacity			Jaw Face	Jaw Opening (Max)		Clamping Surface		Weight (each)		Clevis Type	Supply	
	N	KGF	LBF		in	mm	in	mm	lbs	kgs			
WISE-56GA-1	1,000	100	225	No Jaws	0.6	15	Jaw Dependent		2.4	1.1	15.9	2	
WISE-56GHA-1	1,000	100	225	No Jaws	0.6	15	Jaw Dependent		3.0	1.4	15.9	2	

DIMENSIONS

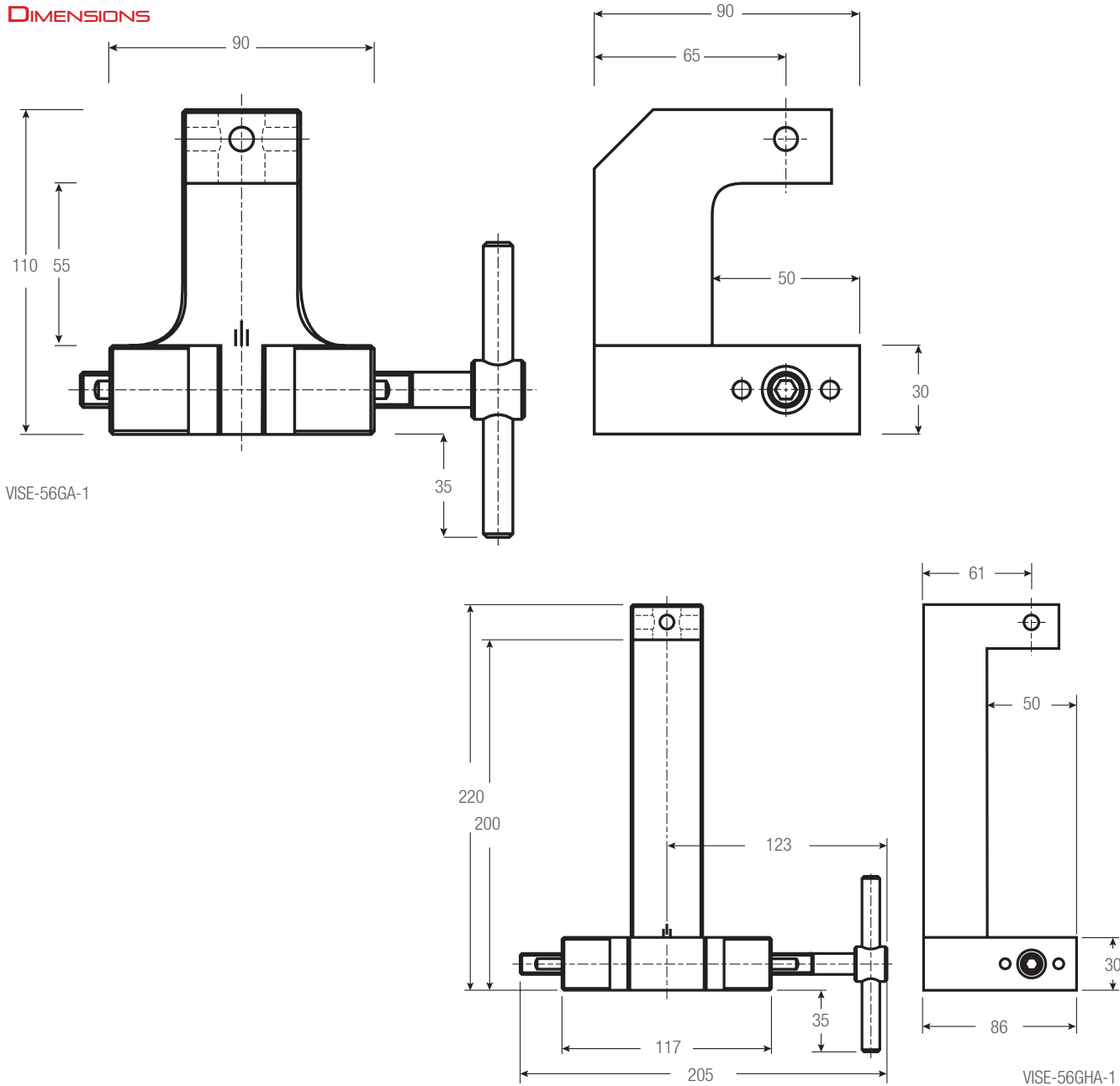

VISE-ACTION FIXTURES

56G JAW SETS

STEEL, HARDENED

- Supplied four (4) jaws per set
- Operating Temperatures 32° to 266°F (0° to 130°C)

Jaw Sets

Model No.	Jaw Face	Jaw Opening (Max)		Clamping Surface	
		in	mm	in	mm
JAW56G-B30	Smooth	0.6	15	1.18 x 1.97	30 x 50
JAW56G-BR30	Rubber	0.5	13	1.18 x 1.97	30 x 50
JAW56G-PY30	Serrated	0.6	15	1.18 x 1.97	30 x 50
JAW56G-V2	V-Notch	0.08-0.6 ϕ	2-15 ϕ	1.18 x 1.97	30 x 50
JAW56G-V3	V-Notch	0.12-0.4 ϕ	3-11 ϕ	1.18 x 1.97	30 x 50
JAW56G-WV30	Wave	0.6	15	1.18 x 1.97	30 x 50
JAW56G-D30	Diamond	0.6	15	1.18 x 1.97	30 x 50

OPTIONAL CARRIER AND CARRIER SETS

STEEL, HARDENED

- Supplies four (4) jaws per set
- Operating Temperatures 32° to 266°F (0° to 130°C)
- Quick change jaw sets requires both CARRIER56K and CAR56K

Carrier Sets

Model No.	Material	Face	Jaw Dimensions (h x w)		Opening Width		Opening Width		Supply (each)
			in	mm	in (h x w)	mm (GA-1)	in (h x w)	mm (GHA-1)	
CARRIER-56G	Steel	-	-	-	-	-	-	-	4
CAR56G-B50	Steel	Smooth	1.18 x 1.97	30 x 50	0 - 0.2	0 - 5	0 - 1.3	0 - 34	4
CAR56G-BR50	Steel	Rubber	1.18 x 1.97	30 x 50	0 - 0.1	0 - 3	0 - 1.2	0 - 32	4
CAR56G-D50	Steel	Diamond	1.18 x 1.97	30 x 50	0 - 0.2	0 - 5	0 - 1.3	0 - 34	4
CAR56G-PY50	Steel	Serrated	1.18 x 1.97	30 x 50	0 - 0.2	0 - 5	0 - 1.3	0 - 34	4

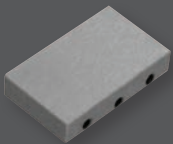

SMOOTH JAW

- Suitable for own further treatments
- Steel-blanks without coating

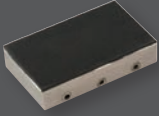

RUBBER-COATED JAW

- 1mm rubber coating (NBR)
- Nickel-plated

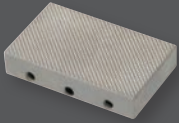

SERRATED JAW

- Pyramids 1.2 x 45°
- Hardened steel 58HRC
- Nickel-plated

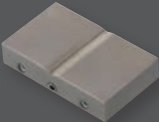

V-NOTCH JAW

- For all kinds of round samples
- Tooth pitch 1.2mm
- Hardened steel
- Nickel-plated

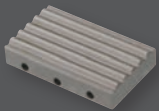

WAVE JAW

- For flexible materials
- Wave 5mm
- Hardened steel 58HRC
- Nickel-plated

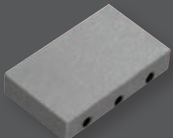

DIAMOND-COATED JAW

- Clamping surface coated with synthetic diamonds
- D91 (170/200 mesh)
- Nickel-plated

VISE-ACTION FIXTURES

9

ALUMINUM, ANODIZED

- For general-purpose tensile testing applications
- For fine wire, filament, string
- Order required jaw set separately
- Operating Temperatures -94° to 356°F (-70° to 180°C)

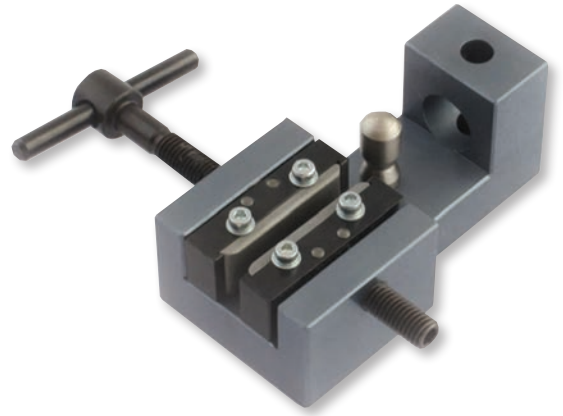

Vise-Action Fixtures

Model No.	Load Capacity			Jaw Face	Jaw Opening (Max)		Clamping Surface		Weight (each)		Clevis Type	Supply
	N	KGF	LBF		in	mm	in	mm	lbs	kgs		
VISE-9	2,500	250	550	No Jaws	0.2	6	Jaw Dependent		0.9	0.4	15.9	2

DIMENSIONS

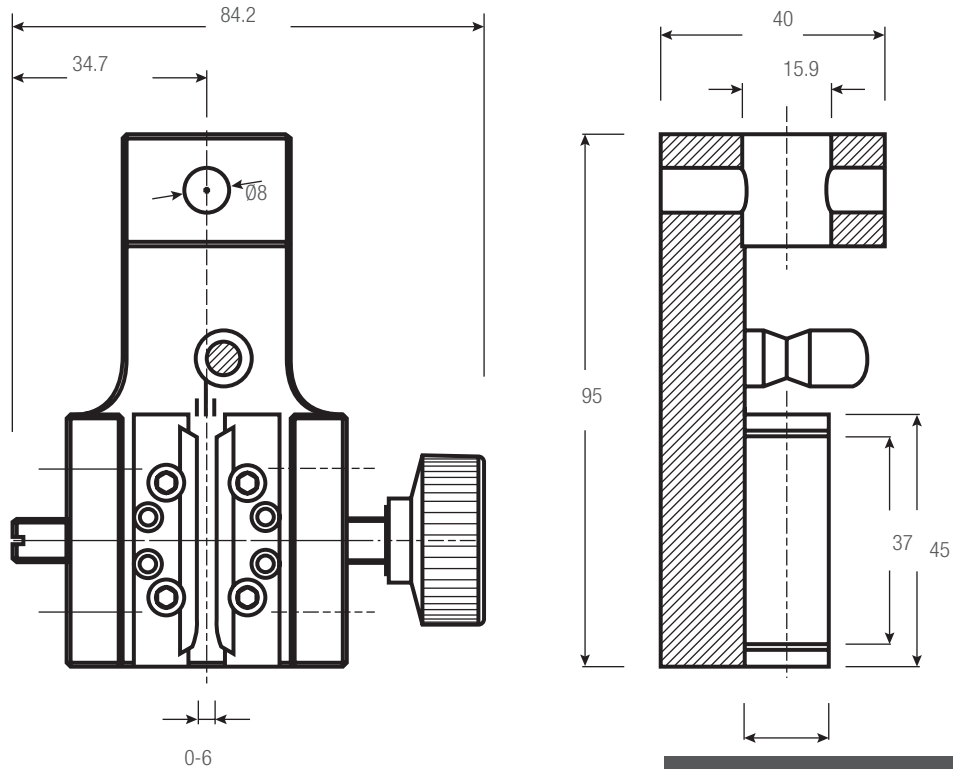

9 JAW SETS

STEEL, HARDENED

- Supplied four (4) jaws per set
- Operating Temperatures 32° to 266°F (0° to 130°C)

Jaw Sets

Model No.	Jaw Face	Jaw Opening (Max)		Clamping Surface	
		in	mm	in	mm
JAW9-B15	Smooth	0.2	6	1.5 x 0.6	37 x 15
JAW9-D15	Diamond	0.2	6	1.5 x 0.6	37 x 15

SMOOTH JAW

- Suitable for own further treatments
- Steel-blanks without coating

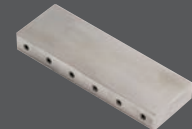

DIAMOND-COATED JAW

- Clamping surface coated with synthetic diamonds
- Nickel-plated

WISE-ACTION FIXTURES

240K

ALUMINUM, ANODIZED

- For general-purpose tensile testing applications
- Dual action tightening from both sides
- Order required jaw set separately
- Operating Temperatures -94° to 356°F (-70° to 180°C)

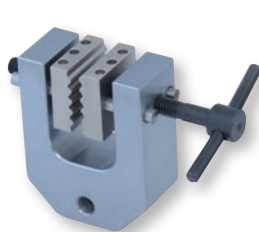

VISE-240KA-1

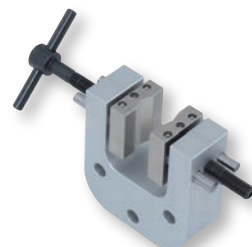

VISE-240KA-20-1



VISE-240KA-30-1

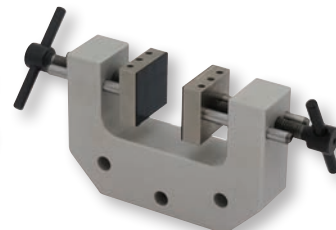

VISE-240KA-50-1

Vise-Action Fixtures

Model No.	Load Capacity			Jaw Face	Jaw Opening (Max)		Clamping Surface		Weight (each)		Clevis Type	Supply
	N	KGF	LBF		in	mm	in	mm	lbs	kgs		
VISE-240KA-1	2,500	250	550	No Jaws	0.4	10	Jaw Dependent		0.7	0.3	15.9	2
VISE-240KA-20-1	1,000	100	225	No Jaws	0.8	20	Jaw Dependent		0.7	0.3	15.9	2
VISE-240KA-30-1	1,000	100	225	No Jaws	1.2	30	Jaw Dependent		0.7	0.3	15.9	2
VISE-240KA-50-1	1,000	100	225	No Jaws	2.0	50	Jaw Dependent		0.7	0.3	15.9	2

DIMENSIONS

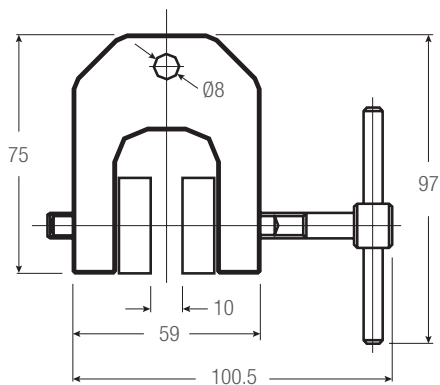

VISE-240KA-1

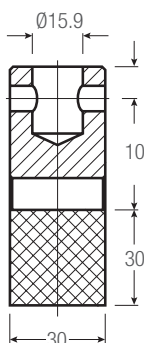

VISE-240KA-20-1

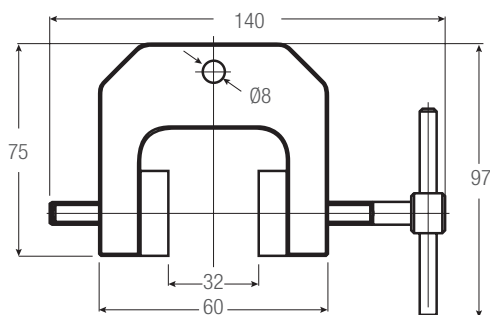
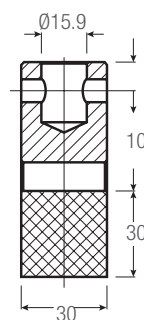
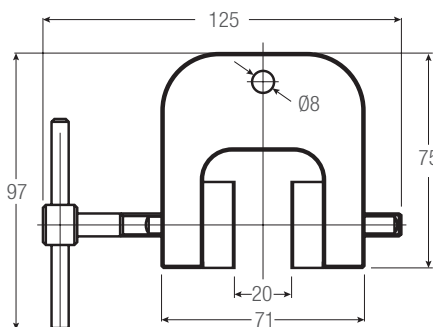

VISE-240KA-30-1

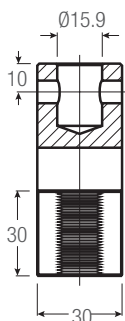

VISE-240KA-50-1

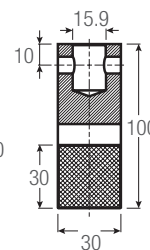
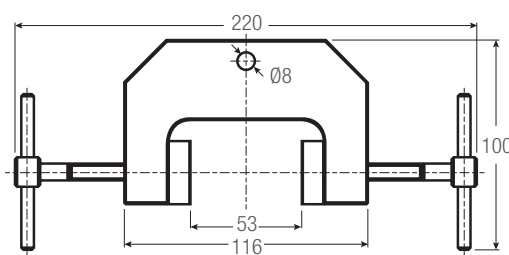

VISE-ACTION FIXTURES

240K JAW SETS

STEEL, HARDENED

- Supplied four (4) jaws per set
- Operating Temperatures 32° to 266°F (0° to 180°C)

Jaw Sets	Jaw Face	Jaw Opening (Max)								Clamping Surface	
		VISE-240KA-1		VISE-240KA-20-1		VISE-240KA-30-1		VISE-240KA-50-1		in	mm
Model No.		in	mm	in	mm	in	mm	in	mm	in	mm
JAW240K-B25	Smooth	0.4	10	0.8	20	1.2	30	2.0	52	1.18 x 1.18	30 x 30
JAW240K-BR25	Rubber	0.3	8	0.7	18	1.1	28	2.0	50	1.18 x 1.18	30 x 30
JAW240K-PY25	Serrated	0.4	10	0.8	20	1.2	30	2.0	52	1.18 x 1.18	30 x 30
JAW240K-V2	V-Notch	0.08-0.35ø	2-9ø	0.08-0.8ø	2-20ø	0.08-1.2ø	2-30ø	0.08-2.05ø	2-52ø	1.18 x 1.18	30 x 30
JAW240K-V9	V-Notch	0.1-0.35ø	3-9ø	0.1-0.8ø	3-20ø	0.1-1.2ø	3-30ø	0.1-2.05ø	3-52ø	1.18 x 1.18	30 x 30
JAW240K-WV30	Wave	0.4	10	0.8	20	1.2	30	2.0	52	1.18 x 1.18	30 x 30
JAW240K-D30	Diamond	0.4	10	0.8	20	1.2	30	2.0	52	1.18 x 1.18	30 x 30
JAW240K-B50	Smooth	0.8	20	0.8	20	1.2	30	2.0	52	1.18 x 2	30 x 50
JAW240K-BR50	Rubber	0.7	18	0.7	18	1.1	28	2.0	50	1.18 x 2	30 x 50
JAW240K-PY50	Serrated	0.8	20	0.8	20	1.2	30	2.0	52	1.18 x 2	30 x 50
JAW240K-WV50	Wave	0.8	20	0.8	20	1.2	30	2.0	52	1.18 x 2	30 x 50
JAW240K-D50	Diamond	0.8	20	0.8	20	1.2	30	2.0	52	1.18 x 2	30 x 50
JAW240K-B80	Smooth	1.2	30	0.8	20	1.2	30	2.0	52	1.18 x 3.2	30 x 80
JAW240K-BR80	Rubber	1.1	28	0.7	18	1.1	28	2.0	50	1.18 x 3.2	30 x 80
JAW240K-PY80	Serrated	1.2	30	0.8	20	1.2	30	2.0	52	1.18 x 3.2	30 x 80
JAW240K-WV80	Wave	1.2	30	0.8	20	1.2	30	2.0	52	1.18 x 3.2	30 x 80
JAW240K-D80	Diamond	1.2	30	0.8	20	1.2	30	2.0	52	1.18 x 3.2	30 x 80
JAW240K-B100	Smooth	2	50	0.8	20	1.2	30	2.0	52	1.18 x 3.9	30 x 100
JAW240K-BR100	Rubber	1.9	48	0.7	18	1.1	28	2.0	50	1.18 x 3.9	30 x 100
JAW240K-PY100	Serrated	2	50	0.8	20	1.2	30	2.0	52	1.18 x 3.9	30 x 100
JAW240K-WV100	Wave	2	50	0.8	20	1.2	30	2.0	52	1.18 x 3.9	30 x 100
JAW240K-D100	Diamond	2	50	0.8	20	1.2	30	2.0	52	1.18 x 3.9	30 x 100

OPTIONAL CARRIER AND CARRIER SETS

STEEL, HARDENED

- Supplied four (4) jaws per set
- Operating Temperatures 32° to 266°F (0° to 130°C)
- Quick change jaw sets require both CARRIER-240K and CAR240K

Carrier Sets													
Model No.	Material	Face	Jaw Dimensions (h x w)		Opening Width		KA-20-1		KA-30-1		KA-50-1		Supply (each)
			in	mm	in	mm	in	mm	in	mm			
CARRIER-240K	Steel	-	-	-	-	-	-	-	-	-	-	-	4
CAR240K-B36	Steel	Smooth	1.2 x 1.2	30 x 30	0 - 0.3	0 - 8	0 - 0.7	0 - 18	0 - 1.1	0 - 28	0 - 1.9	0 - 48	4
CAR240K-BR36	Steel	Rubber	1.2 x 1.2	30 x 30	0 - 0.2	0 - 6	0 - 0.6	0 - 16	0 - 1	0 - 26	0 - 1.8	0 - 46	4
CAR240K-D36	Steel	Diamond	1.2 x 1.2	30 x 30	0 - 0.3	0 - 8	0 - 0.7	0 - 18	0 - 1.1	0 - 28	0 - 1.9	0 - 48	4
CAR240K-PY36	Steel	Serrated	1.2 x 1.2	30 x 30	0 - 0.3	0 - 8	0 - 0.7	0 - 18	0 - 1.1	0 - 28	0 - 1.9	0 - 48	4

WISE-ACTION FIXTURES

240G

ALUMINUM, ANODIZED

- For general-purpose tensile testing applications
- Dual action tightening from both sides
- Order required jaw set separately
- Operating Temperatures -76° to 356°F (-60° to 180°C)

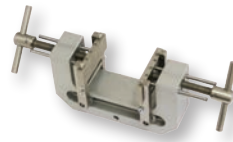

WISE-240G-S100



WISE-240G

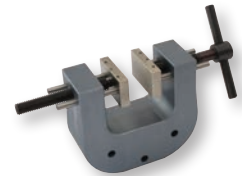

WISE-240G-S50

Vise-Action Fixtures

Model No.	Load Capacity			Jaw Face	Jaw Opening (Max)		Clamping Surface		Weight (each)		Clevis Type	Supply
	N	KGF	LBF		in	mm	in	mm	lbs	kgs		
WISE-240G	5kN	500	1,124	No Jaws	0.9	24	Jaw Dependent		2.9	1.3	15.9	2
WISE-240G-S50	5kN	500	1,124	No Jaws	2.0	50	Jaw Dependent		2.9	1.3	15.9	2
WISE-240G-S100	5kN	500	1,124	No Jaws	4.0	100	Jaw Dependent		5.1	2.3	15.9	2

DIMENSIONS

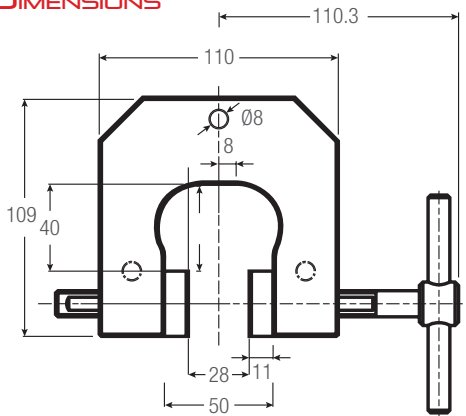

WISE-240G

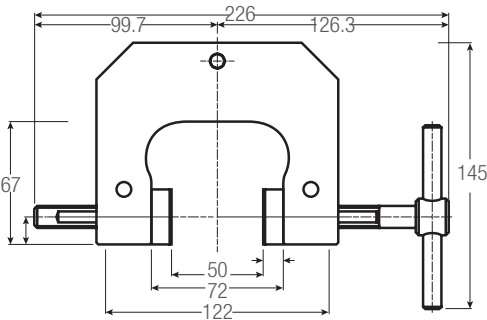
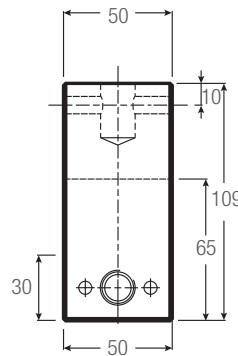

WISE-240G-S50

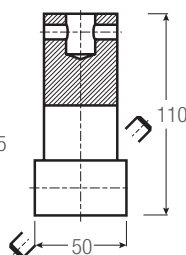

WISE-240G-S100

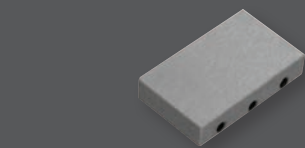
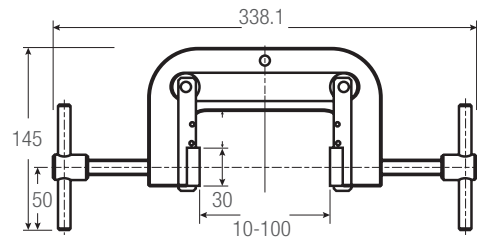
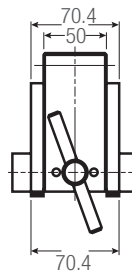

SMOOTH JAW

- Suitable for own further treatments
- Steel-blanks without coating

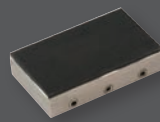

RUBBER-COATED JAW

- 1mm rubber coating (NBR)
- Nickel-plated

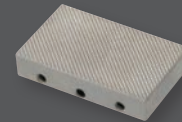

SERRATED JAW

- Pyramids 1.2 x 45°
- Hardened steel 58HRC
- Nickel-plated

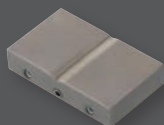

V-NOTCH JAW

- For all kinds of round samples
- Tooth pitch 1.2mm
- Hardened steel
- Nickel-plated

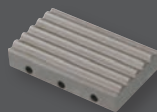

WAVE JAW

- For flexible materials
- Wave 5mm
- Hardened steel 58HRC
- Nickel-plated

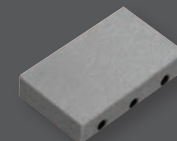

DIAMOND-COATED JAW

- Clamping surface coated with synthetic diamonds
- D91 (170/200 mesh)
- Nickel-plated

VISE-ACTION FIXTURES

240G JAW SETS

STEEL, HARDENED

- Supplied four (4) jaws per set
- Operating Temperatures 32° to 266°F (0° to 180°C)

Jaw Sets									
Model No.	Jaw Face	Jaw Opening (Max)				Clamping Surface			
		VISE-240G-24		VISE-240G-50		VISE-240G-100			
		in	mm	in	mm	in	mm	in	mm
JAW240G-B30	Smooth	0.94	24	1.97	50	-	-	1.18 x 2.0	30 x 50
JAW240G-BR30	Rubber	0.87	22	1.89	48	-	-	1.18 x 2.0	30 x 50
JAW240G-PY30	Serrated	0.94	24	1.97	50	-	-	1.18 x 2.0	30 x 50
JAW240G-V2	V-Notch	0.08-0.94ø	2-24ø	0.08-1.97ø	2-50ø	-	-	1.18 x 2.0	30 x 50
JAW240G-V5	V-Notch	0.2-0.94ø	5-24ø	0.2-1.97ø	5-50ø	-	-	1.18 x 2.0	30 x 50
JAW240G-WV30	Wave	0.94	24	1.97	50	-	-	1.18 x 2.0	30 x 50
JAW240G-D30	Diamond	0.94	24	1.97	50	-	-	1.18 x 2.0	30 x 50
JAW240G-B80	Smooth	1.02	26	1.89	48	0.4-4.0	10-100	1.18 x 3.2	30 x 80
JAW240G-BR80	Rubber	0.95	24	1.81	46	0.3-3.9	8-98	1.18 x 3.2	30 x 80
JAW240G-PY80	Serrated	1.02	26	1.89	48	0.4-4.0	10-100	1.18 x 3.2	30 x 80
JAW240G-WV80	Wave	1.02	26	1.89	48	0.4-4.0	10-100	1.18 x 3.2	30 x 80
JAW240G-D80	Diamond	1.02	26	1.89	48	0.4-4.0	10-100	1.18 x 3.2	30 x 80
JAW240G-B100	Smooth	1.02	26	1.89	48	0.4-4.0	10-100	1.18 x 3.9	30 x 100
JAW240G-BR100	Rubber	0.95	24	1.81	46	0.3-3.9	8-98	1.18 x 3.9	30 x 100
JAW240G-PY100	Serrated	1.02	26	1.89	48	0.4-4.0	10-100	1.18 x 3.9	30 x 100
JAW240G-WV100	Wave	1.02	26	1.89	48	0.4-4.0	10-100	1.18 x 3.9	30 x 100
JAW240G-D100	Diamond	1.02	26	1.89	48	0.4-4.0	10-100	1.18 x 3.9	30 x 100

OPTIONAL CARRIER AND CARRIER SETS

STEEL, HARDENED

- Supplied four (4) jaws per set
- Operating Temperatures 32° to 266°F (0° to 130°C)
- Quick change jaw sets require both CARRIER-240G and CAR240G

Carrier Sets										
Model No.	Material	Face	Jaw Dimensions (h x w)		Opening Width		240G-S50		240G-S100	Supply (each)
			in	mm	in	mm	in	mm	mm	
CARRIER-240G	Steel	-	-	-	-	-	-	-	-	4
CAR240G-B50	Steel	Smooth	1.2 x 2.0	30 x 50	0 - 0.8	0 - 20	0 - 1.18	0 - 30	Not Compatible	4
CAR240G-BR50	Steel	Rubber	1.2 x 2.0	30 x 50	0 - 0.7	0 - 18	0 - 1.18	0 - 30	Not Compatible	4
CAR240G-D50	Steel	Diamond	1.2 x 2.0	30 x 50	0 - 0.8	0 - 20	0 - 1.18	0 - 30	Not Compatible	4
CAR240G-PY50	Steel	Serrated	1.2 x 2.0	30 x 50	0 - 0.8	0 - 20	0 - 1.18	0 - 30	Not Compatible	4

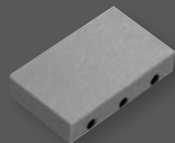

SMOOTH JAW

- Suitable for own further treatments
- Steel-blanks without coating

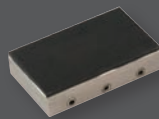

RUBBER-COATED JAW

- 1mm rubber coating (NBR)
- Nickel-plated

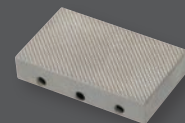

SERRATED JAW

- Pyramids 1.2 x 45°
- Hardened steel 58HRC
- Nickel-plated

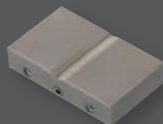

V-NOTCH JAW

- For all kinds of round samples
- Tooth pitch 1.2mm
- Hardened steel
- Nickel-plated

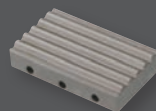

WAVE JAW

- For flexible materials
- Wave 5mm
- Hardened steel 58HRC
- Nickel-plated

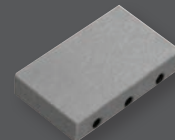

DIAMOND-COATED JAW

- Clamping surface coated with synthetic diamonds
- D91 (170/200 mesh)
- Nickel-plated

WISE-ACTION FIXTURES

154

ALUMINUM, ANODIZED (WISE-154-10)

STEEL, MANGANESE PHOSPHATED (WISE-154-20)

- For general-purpose tensile testing applications
- Dual action tightening from both sides
- Order required jaw set separately
- Operating Temperatures
 - VISE-154A-10-1 32° to 356°F (0° to 180°C)
 - VISE-154S-20-1 32° to 662°F (0° to 350°C)

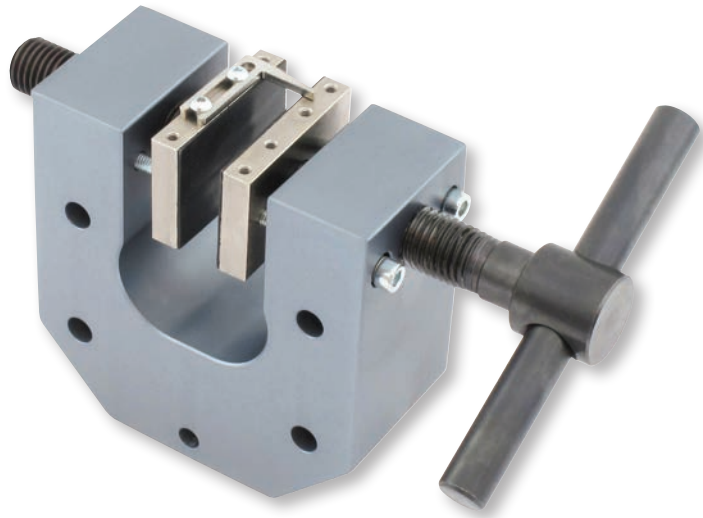

WISE-ACTION FIXTURES

Vise-Action Fixtures

Model No.	Load Capacity			Jaw Face	Jaw Opening (Max)		Clamping Surface		Weight (each)		Clevis Type	Supply
	N	KGf	LBF		in	mm	in	mm	lbs	kgs		
VISE-154A-10-1	10K	1,000	2,200	No Jaws	Jaw Dependent	Jaw Dependent	Jaw Dependent	Jaw Dependent	5.3	2.4	15.9	2
VISE-154S-20-1	20K	2,000	4,400	No Jaws	Jaw Dependent	Jaw Dependent	Jaw Dependent	Jaw Dependent	11.0	5.0	15.9	2

DIMENSIONS

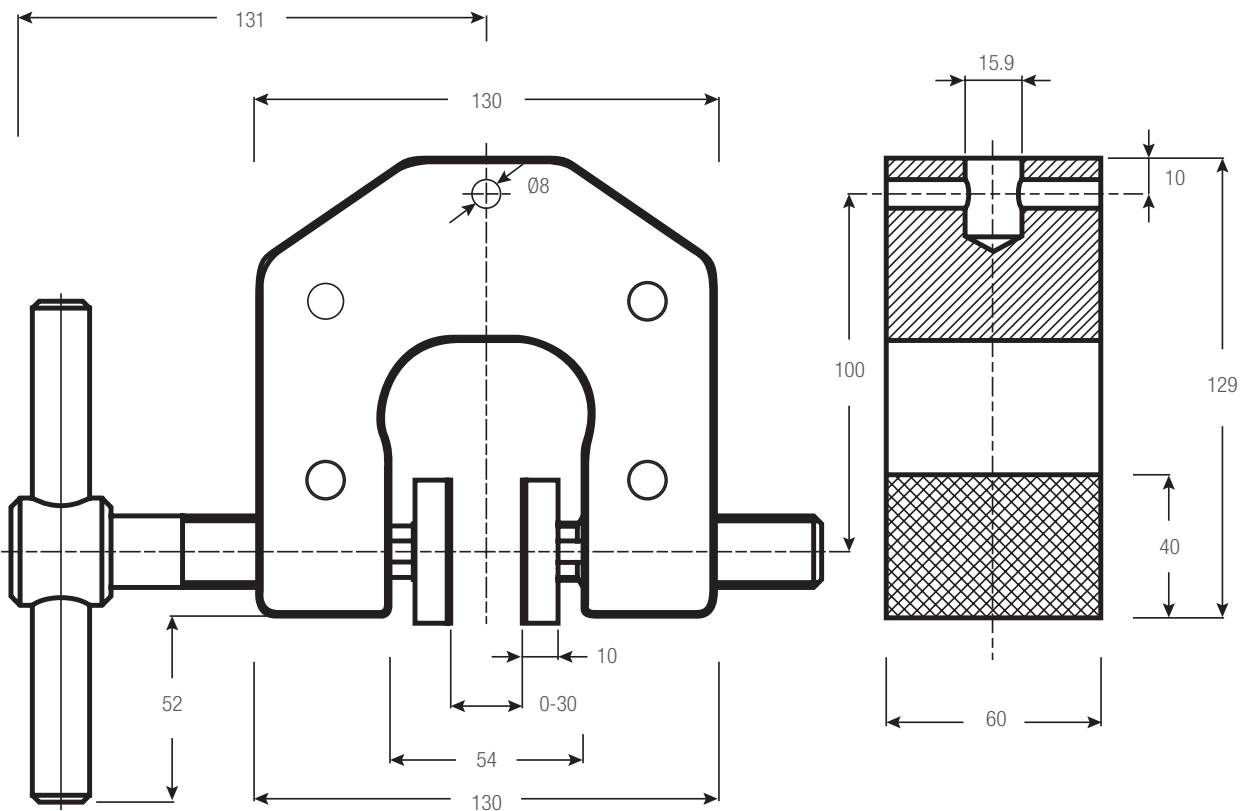

VISE-ACTION FIXTURES

154 JAW SETS

STEEL, HARDENED

- Supplied four (4) jaws per set
- Operating Temperatures 32° to 266°F (0° to 180°C)

Jaw Sets					
Model No.	Jaw Face	Jaw Opening (Max)		Clamping Surface	
		in	mm	in	mm
JAW154-B60	Smooth	1.34	34	1.6 x 2.4	40 x 60
JAW154-BR60	Rubber	1.26	32	1.6 x 2.4	40 x 60
JAW154-PY60	Serrated	1.34	34	1.6 x 2.4	40 x 60
JAW154-V4	V-Notch	0.16-0.47ø	4-12ø	1.6 x 2.4	40 x 60
JAW154-V6	V-Notch	0.24-1.34ø	6-34ø	1.6 x 2.4	40 x 60
JAW154-WV60	Wave	1.34	34	1.6 x 2.4	40 x 60
JAW154-D60	Diamond	1.34	34	1.6 x 2.4	40 x 60
JAW154-B100	Smooth	1.18	30	1.6 x 3.9	40 x 100
JAW154-BR100	Rubber	1.1	28	1.6 x 3.9	40 x 100
JAW154-PY100	Serrated	1.18	30	1.6 x 3.9	40 x 100
JAW154-WV100	Wave	1.18	30	1.6 x 3.9	40 x 100
JAW154-D100	Diamond	1.18	30	1.6 x 3.9	40 x 100

OPTIONAL CARRIER AND CARRIER SETS

STEEL, HARDENED

- Supplied four (4) jaws per set
- Operating Temperatures 32° to 266°F (0° to 130°C)
- Quick change jaw sets require both CARRIER-154 and CAR154

Carrier Sets							
Model No.	Material	Face	Jaw Dimensions (h x w)		Opening Width		Supply (each)
			mm	in	mm	in	
CARRIER-154	Steel	-	-	-	-	-	4
CAR154-BR60	Steel	Rubber	40 x 60	1.5 x 2.3	0 - 22	0 - 0.8	4
CAR154-D60	Steel	Diamond	40 x 60	1.5 x 2.3	0 - 24	0 - 0.9	4
CAR154-PY60	Steel	Serrated	Clamp Height: 40	1.5	0 - 24	0 - 0.9	4
CAR154-V4	Steel	Vee-Type	Clamp Height: 40	1.5	4 - 24 Ø	0.15 - .9	4
CAR154-B60	Steel	Smooth	40 x 60	1.5 x 2.3	0 - 22	0 - 0.8	4
CAR154-WV60	Steel	Wave	40 x 60	1.5 x 2.3	0 - 24	0 - 0.9	4
CARRIER-154-100	Steel	-	-	-	-	-	4
CAR154-B100	Steel	Smooth	50 x 100	1.9 x 3.9	0 - 16	0 - 0.6	4
CAR154-BR100	Steel	Rubber	50 x 100	1.9 x 3.9	0 - 14	0 - 0.5	4
CAR154-WV100	Steel	Wave	50 x 100	1.9 x 3.9	0 - 16	0 - 0.6	4
CAR154-D100	Steel	Diamond	50 x 100	1.9 x 3.9	0 - 16	0 - 0.6	4
CAR154-PY100	Steel	Serrated	50 x 100	1.9 x 3.9	0 - 16	0 - 0.6	4

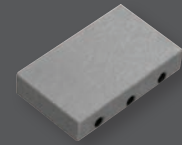

SMOOTH JAW

- Suitable for own further treatments
- Steel-blanks without coating

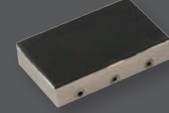

RUBBER-COATED JAW

- 1mm rubber coating (NBR)
- Nickel-plated

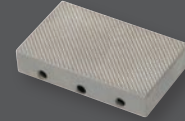

SERRATED JAW

- Pyramids 1.2 x 45°
- Hardened steel 58HRC
- Nickel-plated

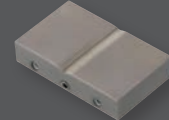

V-NOTCH JAW

- For all kinds of round samples
- Tooth pitch 1.2mm
- Hardened steel
- Nickel-plated

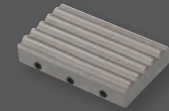

WAVE JAW

- For flexible materials
- Wave 5mm
- Hardened steel 58HRC
- Nickel-plated

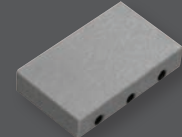

DIAMOND-COATED JAW

- Clamping surface coated with synthetic diamonds
- D91 (170/200 mesh)
- Nickel-plated

WISE-ACTION FIXTURES

90

STEEL, MANGANESE PHOSPHATE COATING

- For general-purpose tensile testing applications
- Dual action tightening from both sides
- Order required jaw set separately
- Operating temperature: 32° to 356°F (0° t 0 180°C)

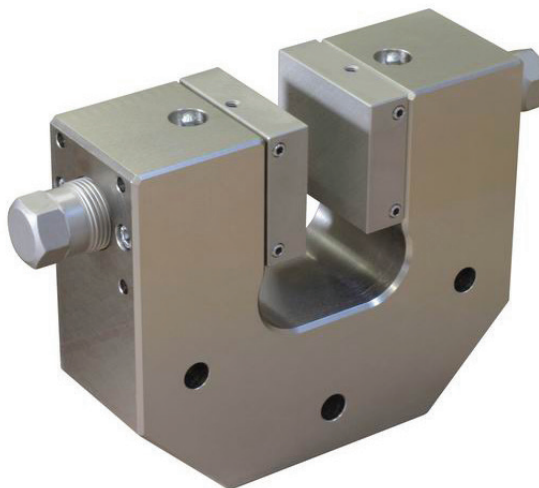

Vise-Action Fixtures											
Part Number	Load Capacity			Material	Jaw Opening (Max)		Face	Weight (each)		Clevis Type mm	Supply
	N	KGf	LBF		in	mm		lbs	kgs		
WISE-90-50	50kN	5,000	11,250	Steel	Jaw Dependent		No Jaw Face	26.4	12	31.7	2

Jaw Sets						
Part Number	Material	Jaw Opening (Max)		Face	Jaw Dimensions mm (h x w)	Supply
		in	mm			
JAW90-PY66	Steel	0-1.18	0-30	Serrated	60 x 66	4

DIMENSIONS

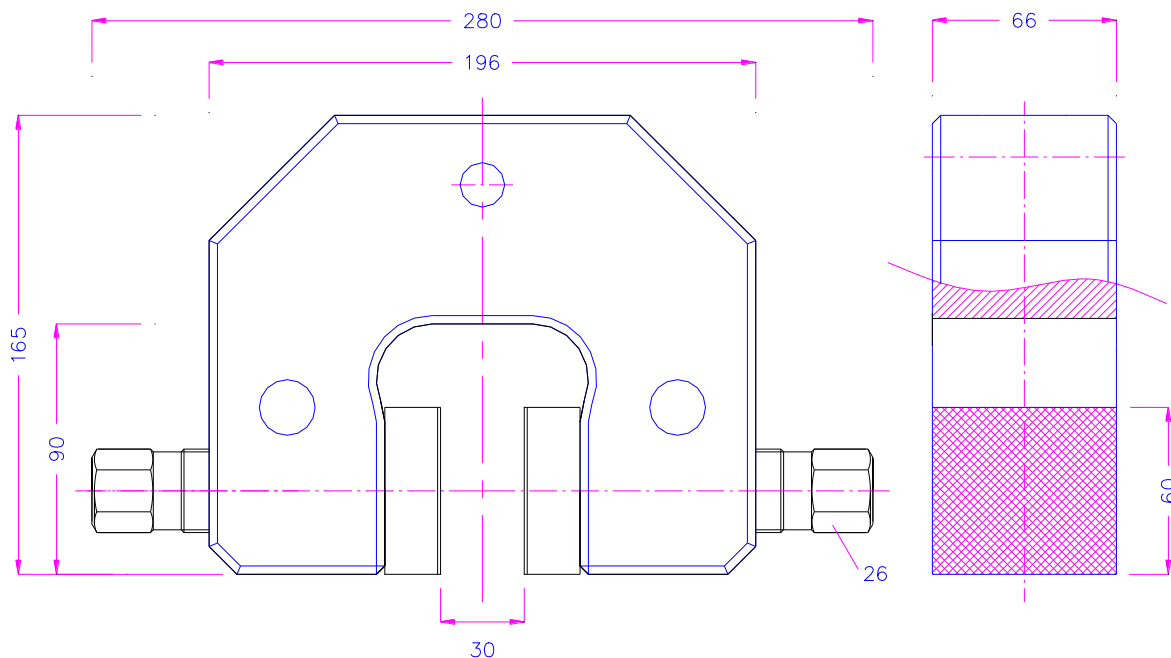



PRECISION MAKES THE DIFFERENCE



NO CONTACT IS THE SOLUTION.

Profile360™ is an in-line, real-time, non-contact solution for continuously monitoring key profile dimensions in complex shapes such as rubber, ceramic, plastic, and wood-plastic composite extrusions, roll-formed metal profiles, and profiled wire.

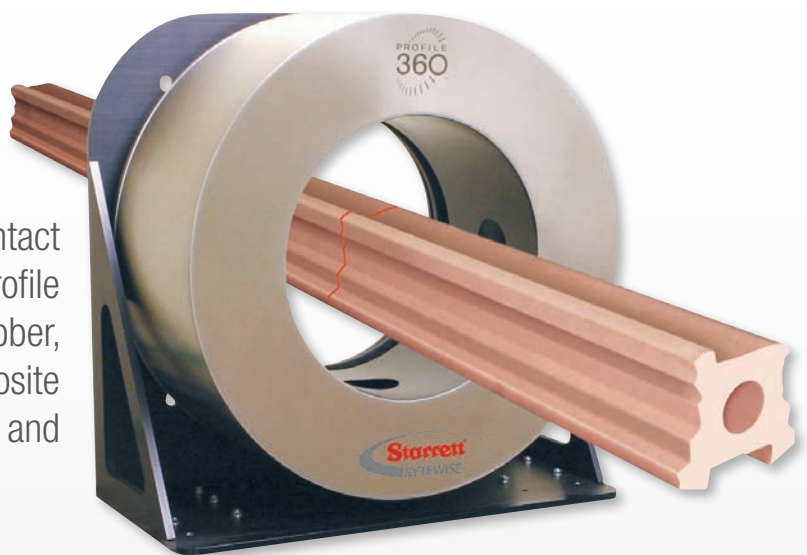

Starrett®

(978) 249-3551 • starrett.com

Follow us!





WEDGE-ACTION FIXTURES

WEDGE-ACTION FIXTURES

Wedge fixtures are self-tightening. Starrett offers a variety of different wedge-action fixtures with various face types for flat and round sample dimensions.

Wedge-action fixtures can be equipped with smooth, serrated, v-notch, diamond-coated and rubber surfaces.

Starrett can assist you in selecting the proper wedge-action fixture and jaw face set for your sample.

OPERATION

Wedge-action test fixtures are designed for easy sample loading and alignment. These test fixtures apply an increasing pressure on the sample as the sample is pulled axially.

Starrett offers a variety of wedge-action test fixtures with different capacities. We also offer a wide assortment of grip faces including smooth, serrated, v-notch, diamond and rubber.

TESTING STANDARDS

There are a variety of testing standards that can make use of a wedge-action test fixture. Contact your Starrett representative for more information about your specific testing method and the available test fixtures.

Wedge-Action Fixtures						
Model No.	Load Capacity			Sample Width	Sample Thickness	Type
	N	KGf	LBF			
WEDGE-7S-1	5,000	500	1,100	10 mm	8 mm	Clevis
WEDGE-256S-1	10K	1,000	2,200	30 mm	8 mm	Clevis
WEDGE-243S-1	20K	2,000	4,400	Jaw Dependent	Jaw Dependent	Clevis
WEDGE-243S-50	50K	5,000	11,000	Jaw Dependent	Jaw Dependent	Clevis
WEDGE-527S-1	50K	5,000	11,000	80 mm	Jaw Dependent	Clevis



WEDGE-ACTION FIXTURES

Wedge-action fixtures are ideal for production applications where fast and precise sampling loading is required. These fixtures help ensure proper sample alignment. As the applied load increases, the gripping force on the sample increases.

Some wedge-action grips can be equipped with various types of jaw faces making them ideal for flat or round samples. Jaw face sets include four jaw faces and are ordered separately unless otherwise noted.

7

STEEL, NICKEL FINISH

- For general-purpose tensile testing applications
- For small diameter samples
- Has closed back
- Jaw faces must be ordered separately
- Operating Temperatures 32° to 266°F (0° to 130°C)

DIMENSIONS

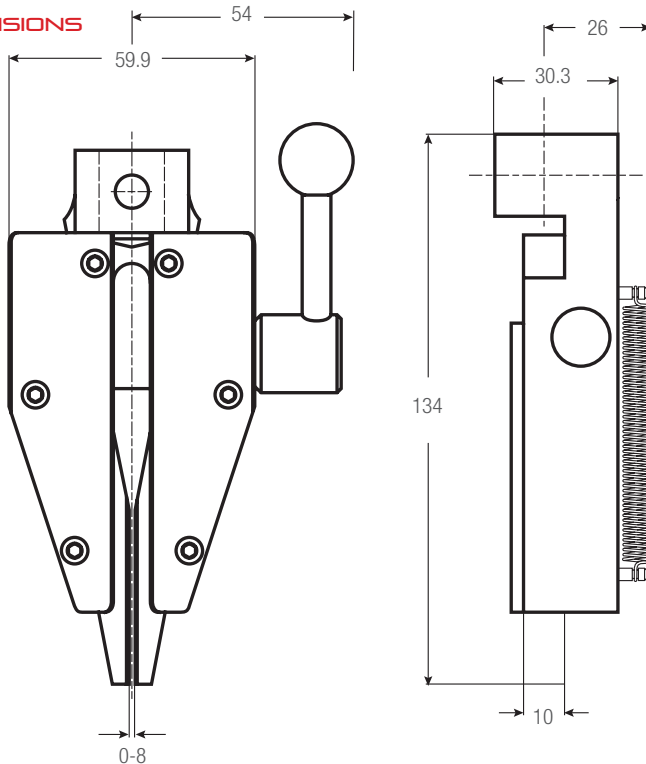

Wedge-Action Fixtures													
Model No.	Load Capacity			Base Plate	Jaw Face	Sample Width (Max)		Sample Thickness (Max)		Weight (each)		Clevis Type	Supply
	N	KGF	LBF			in	mm	in	mm	lbs	kgs		
WEDGE-7S-1	5,000	500	1,100	Aluminum	No Jaws	0.39	10	0.31	8	1.98	0.9	15.9	2

7 JAW SETS

STEEL, HARDENED

- Supplied four (4) jaws per set
- Operating Temperatures 32° to 266°F (0° to 130°C)

Jaw Sets					
Model No.	Jaw Face	Jaw Opening (Max)		Clamping Surface	
		in	mm	in	mm
JAW7-PY	Serrated	0.3	8	0.4 x 1.6	10 x 40
JAW7-V2	V-Notch	0.08-0.4	2-10	0.4 x 1.6	10 x 40



SERRATED JAW

- Pyramids 1.2 x 45°
- Hardened steel 58HRC
- Nickel-plated



V-NOTCH JAW

- For round samples
- 0.8mm tooth pitch
- Hardened steel 58HRC
- Nickel-plated

WEDGE-ACTION FIXTURES

256

STEEL, PHOSPHATE FINISH

- For general-purpose tensile testing applications
- Has a closed back so sample is loaded from front side only
- Spring-loaded, lever operation
- Jaw faces must be ordered separately
- Operating Temperatures 32° to 266°F (0° to 130°C)



DIMENSIONS

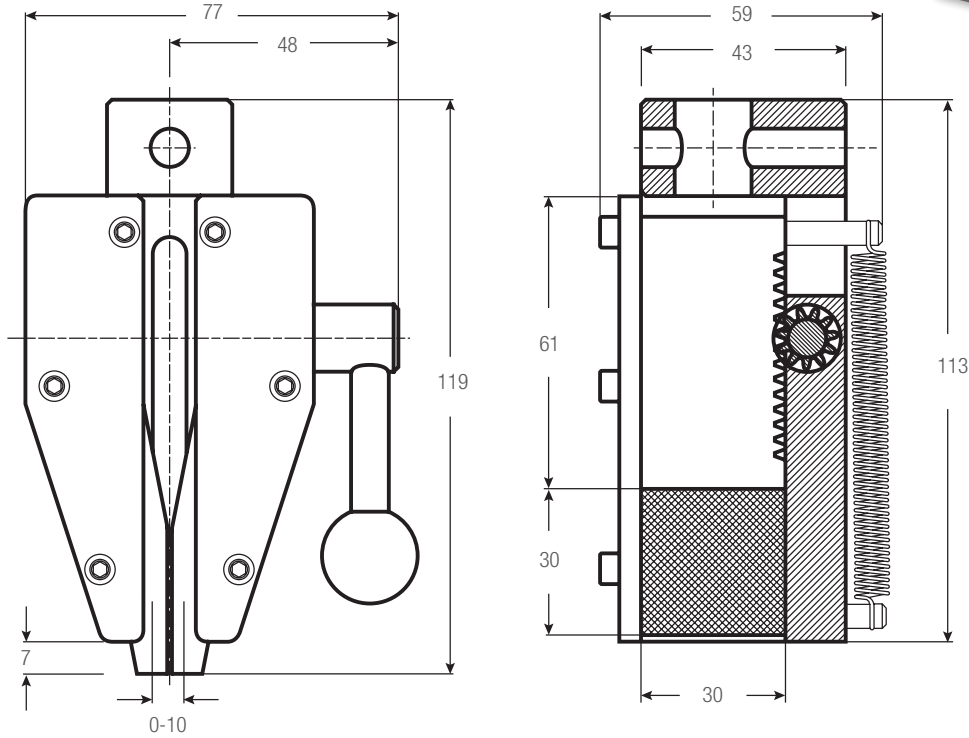

Wedge-Action Fixtures													
Model No.	Load Capacity			Base Plate	Jaw Face	Sample Width (Max)		Sample Thickness (Max)		Weight (each)		Clevis Type	Supply
	N	KGF	LBF			in	mm	in	mm	lbs	kgs		
WEDGE-256S-1	10K	1,000	2,200	Aluminum	No Jaws	1.2	30	0.31	8	3.1	1.4	15.9	2

256 JAW SETS

STEEL, HARDENED

- Supplied four (4) jaws per set
- Operating Temperatures 32° to 266°F (0° to 130°C)

Jaw Sets					
Model No.	Jaw Face	Jaw Opening (Max)		Clamping Surface	
		in	mm	in	mm
JAW256-PY	Serrated	0.4	10	1.2 x 1.2	30 x 30
JAW256-V2	V-Notch	0.08-0.4 ϕ	2-10 ϕ	1.2 x 1.2	30 x 30
JAW256-D30	Diamond	0.4	10	1.2 x 1.2	30 x 30



SERRATED JAW

- Pyramids 1.2 x 45°
- Hardened steel 58HRC
- Nickel-plated

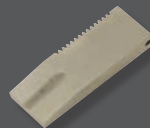

V-NOTCH JAW

- For round samples
- 1.2mm tooth pitch
- Hardened steel 58HRC
- Nickel-plated

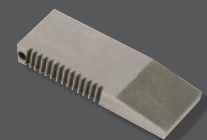

DIAMOND JAW

- Hardened steel 58HRC
- Nickel-plated

WEDGE-ACTION FIXTURES

243

STEEL, PHOSPHATE FINISH

- For general-purpose tensile testing applications
- Has a closed back so sample is loaded from front side only
- Spring-loaded, lever operation
- Jaw faces must be ordered separately
- Operating Temperatures 32° to 266°F (0° to 130°C)

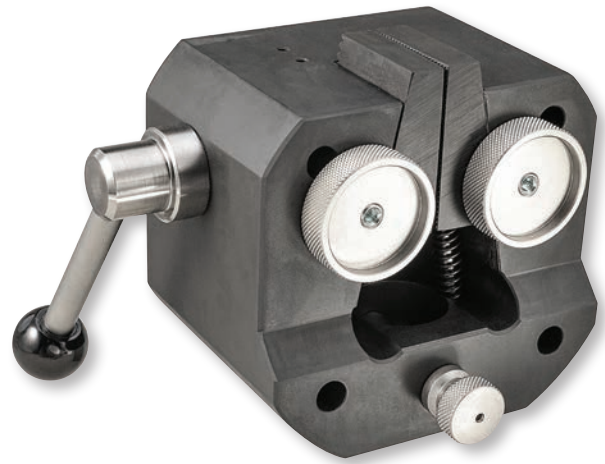

Wedge-Action Fixtures

Model No.	Load Capacity			Jaw Face	Sample Width (Max)		Sample Thickness (Max)		Weight (each)		Clevis Type mm	Supply
	N	KGF	LBF		in	mm	in	mm	lbs	kgs		
WEDGE-243S-1	20K	2,000	4,400	No Jaws	Jaw Dependent	Jaw Dependent	Jaw Dependent	Jaw Dependent	8.4	3.8	15.9	2
WEDGE-243S-50	50K	5,000	11,000	No Jaws	Jaw Dependent	Jaw Dependent	Jaw Dependent	Jaw Dependent	15.0	6.8	31.8	2

DIMENSIONS

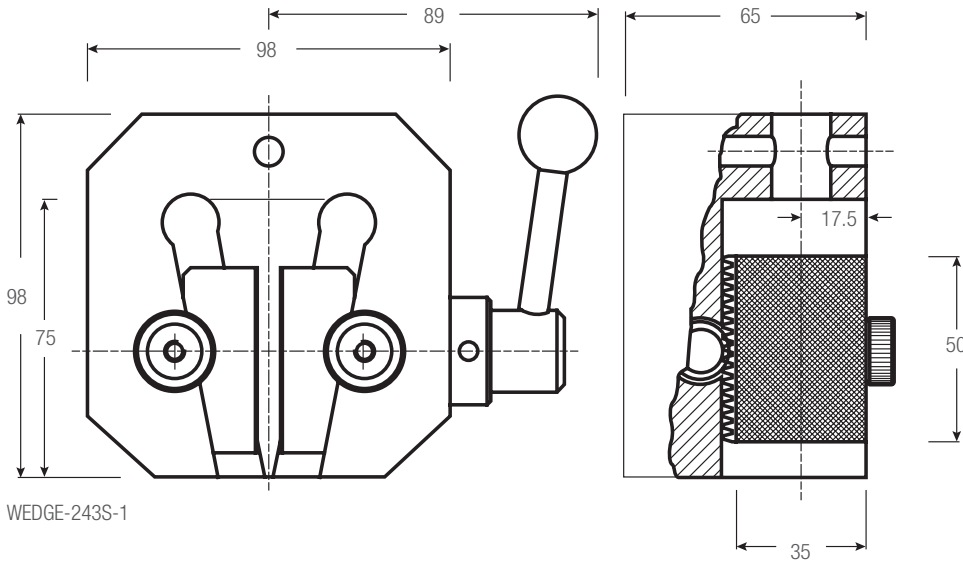

WEDGE-243S-1

243 JAW SETS

STEEL, HARDENED

- Supplied four (4) jaws per set
- Operating Temperatures 32° to 266°F (0° to 130°C)

Jaw Sets

Model No.	Jaw Face	Jaw Opening (Max)		Clamping Surface	
		in	mm	in	mm
JAW243-PY13	Serrated	0.5	13	1.97 x 1.4	50 x 35
JAW243-PY16	Serrated	0.6	16	1.97 x 1.4	50 x 35
JAW243-V3	V-Notch	0.01-0.5 ϕ	3-13 ϕ	1.97 height	50mm height
JAW243-V4	V-Notch	0.15-0.6 ϕ	4-16	1.97 height	50mm height
JAW243-V10	V-Notch	0.39-0.8 ϕ	10-20	1.97 height	50mm height

SERRATED JAW

- Pyramids 1.2 x 45°
- Hardened steel 58HRC
- Nickel-plated



V-NOTCH JAW

- For round samples
- 1.2mm tooth pitch
- Hardened steel 58HRC
- Nickel-plated

WEDGE-ACTION FIXTURES

527

STEEL, PHOSPHATE FINISH

- For general-purpose tensile testing applications
- Capstan tightening
- Jaw faces must be ordered separately
- Operating Temperatures 32° to 266°F (0° to 130°C)



Wedge-Action Fixtures													
Model No.	Load Capacity			Sample Height (Max)		Sample Width (Max)		Sample Thickness (Max)		Weight (each)		Clevis Type	Supply
	N	KGF	LBF	in	mm	in	mm	in	mm	lbs	kgs	mm	
WEDGE-5275-1	50K	5,000	11,000	283	11.1	3.1	80	Jaw Dependent	17	37.5	31.8	31.8	2

DIMENSIONS

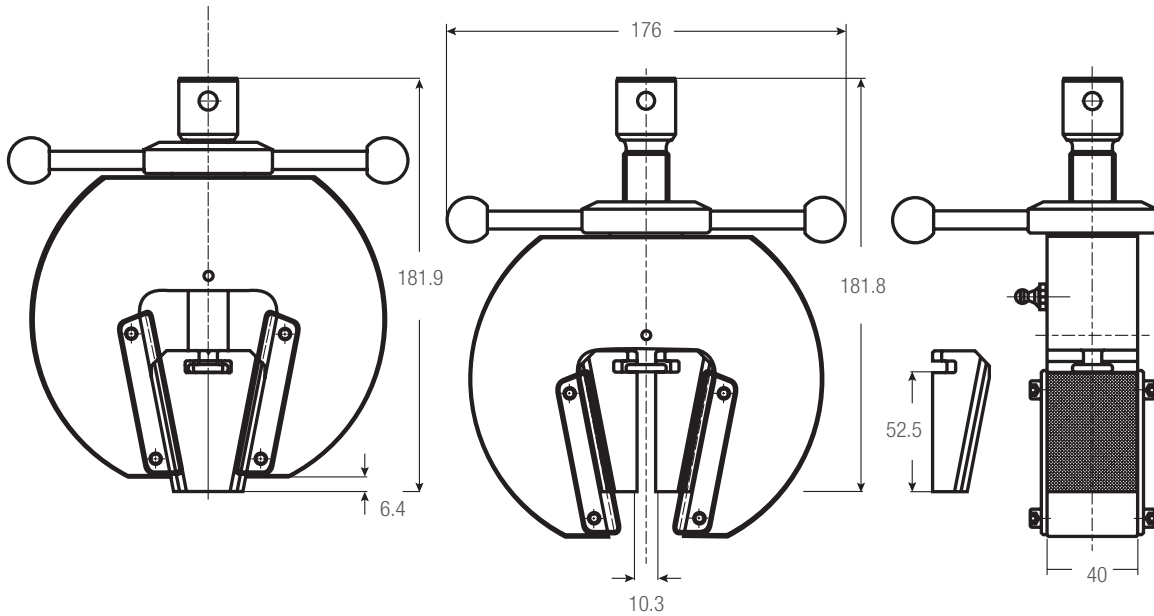

527 JAW SETS

STEEL, HARDENED

- Supplied four (4) jaws per set
- Operating Temperatures 32° to 266°F (0° to 130°C)

Jaw Sets					
Model No.	Jaw Face	Jaw Opening (Max)		Clamping Surface	
		in	mm	in	mm
JAW527-PY30	Serrated	0.65	17	2.6 x 3.2	66 x 80
JAW527-V17	V-notch	0.15-0.7 \emptyset	4-17 \emptyset	2.6 x 3.2	66 x 80
JAW527-V30	V-notch	0.6-1.2 \emptyset	16-30 \emptyset	2.6 x 3.2	66 x 80



SERRATED JAW

- Pyramids 1.2 x 45°
- Hardened steel 58HRC
- Nickel-plated



V-NOTCH JAW

- For round samples
- 1.2mm tooth pitch
- Hardened steel 58HRC
- Nickel-plated



ROPE AND BOLLARD FIXTURES

ROPE FIXTURES

Starrett rope fixtures are used for testing rope, cable, filament, yarns, etc.

These fixtures are used for tensile applications. Features include a guide roller that helps prevent breakage within the test fixture.

OPERATION

Rope fixtures feature a design that helps ensure proper sample alignment and that promotes a correct sample break between the upper and lower test fixture. These fixtures feature a spool used to wrap the sample. The sample is typically wrapped around the spool 1-1/2 or 2 times depending on the strength of the material.

These rope fixtures let you position your material under test around a cylindrical spool so that force is applied directly in line with the load cell sensor.

TESTING STANDARDS

There are a variety of testing standards for rope, filament, cords, fine wires and cables. Contact your Starrett representative for more information about your specific testing method and the available test fixtures.



Rope Fixtures

Model No.	Load Capacity			Jaw Face Type	Roller Diameter	Sample Diameter
	N	KGF	LBF			
ROPE-76-1A-1	1,000	100	225	Rubber	20 mm ø	2 mm ø
ROPE-76-1A-D	1,000	100	225	Diamond	20 mm ø	2 mm ø
ROPE-76-5A-1	5,000	500	1,100	Serrated	40 mm ø	5mm ø
ROPE-76-5A-D	5,000	500	1,100	Diamond	40 mm ø	5mm ø
ROPE-255-10-PY	10K	1,000	2,200	Serrated	26 mm ø	5mm ø
ROPE-255-10-D	10K	1,000	2,200	Diamond	26 mm ø	5mm ø
ROPE-76-20S-1	20K	2,000	4,500	Serrated	94 mm ø	9 mm ø
ROPE-170-50	50K	5,000	11,000	Serrated	162 mm ø	20 mm ø

ROPE FIXTURES

76

ALUMINUM, ANODIZED FINISH

- For general-purpose tensile testing applications
- Use on small diameter wire, rope, filaments, thread, etc.
- Operating Temperatures
 - ROPE-76-1: 32° to 158°F (0° to 70°C)
 - ROPE-76-5: 32° to 356°F (0° to 180°C)

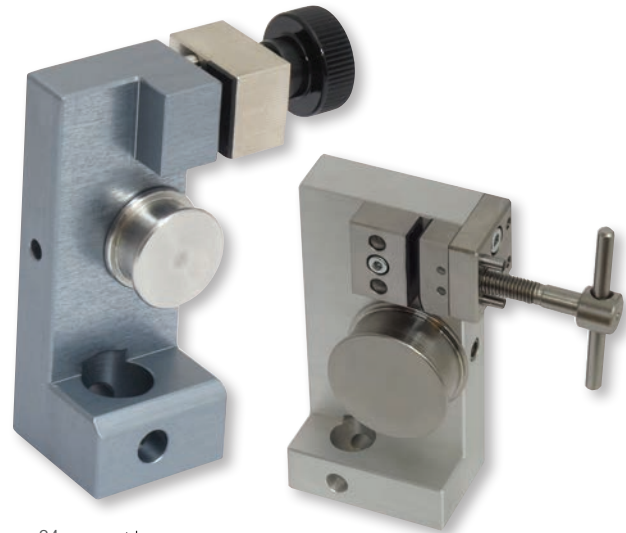

DIMENSIONS

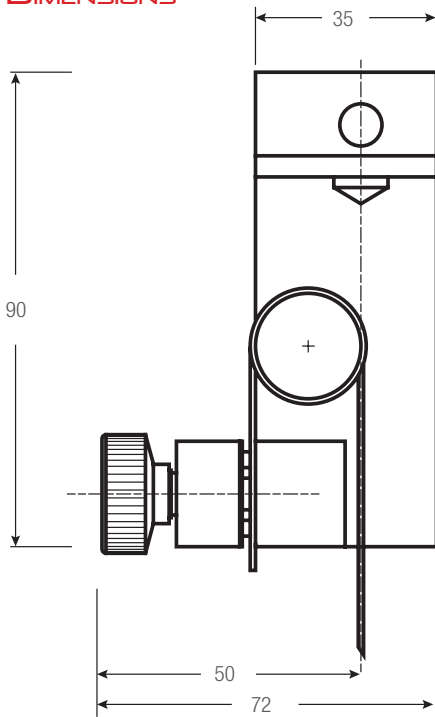

ROPE-76-1A-1

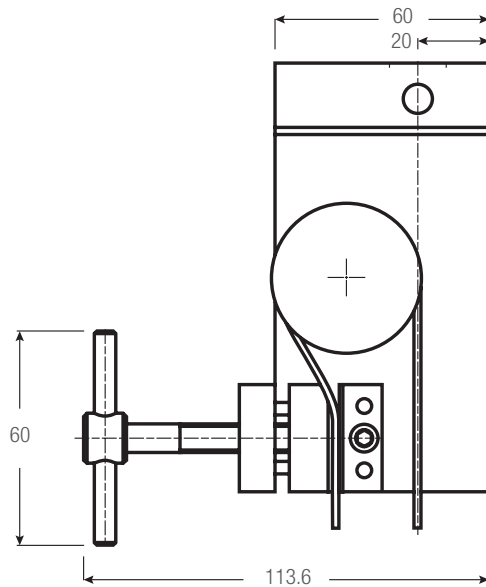
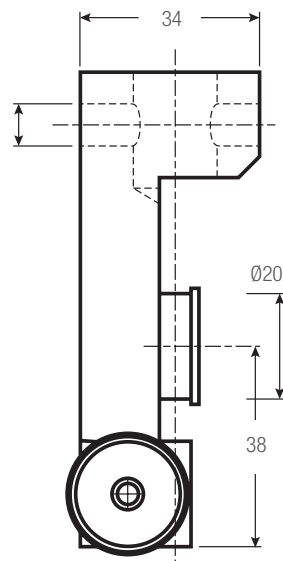

ROPE-76-5A-1

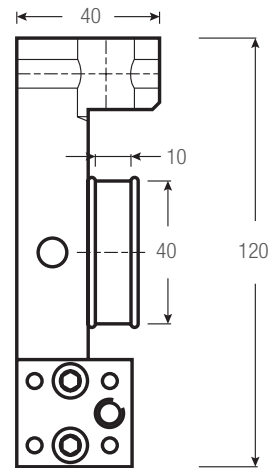

Rope Fixtures

Model No.	Load Capacity			Jaw Face	Roller ϕ		Sample ϕ (Max)		Clamping Surface (h x w)		Weight (each)		Clevis Type	Supply
	N	KGF	LBF		in	mm	in	mm	in	mm	lbs	kgs		
ROPE-76-1A-1	1,000	100	225	Rubber	0.8	20	0.08	2	0.8 x 0.4	20 x 10	0.7	0.3	15.9	2
ROPE-76-1A-D	1,000	100	225	Diamond	0.8	20	0.08	2	0.8 x 0.4	20 x 10	0.7	0.3	15.9	2
ROPE-76-5A-1	5,000	500	1,100	Serrated	1.6	40	0.2	5	1.2 x 0.5	30 x 12	2.0	0.9	15.9	2
ROPE-76-5A-D	5,000	500	1,100	Diamond	1.6	40	0.2	5	1.2 x 0.5	30 x 12	2.0	0.9	15.9	2

ROPE FIXTURES

76

STEEL, NICKEL FINISH

- For general-purpose tensile testing applications up to 20kN
- Use on small diameter wire, rope, filaments, thread, etc.
- Operating Temperatures 32° to 356°F (0° to 180°C)

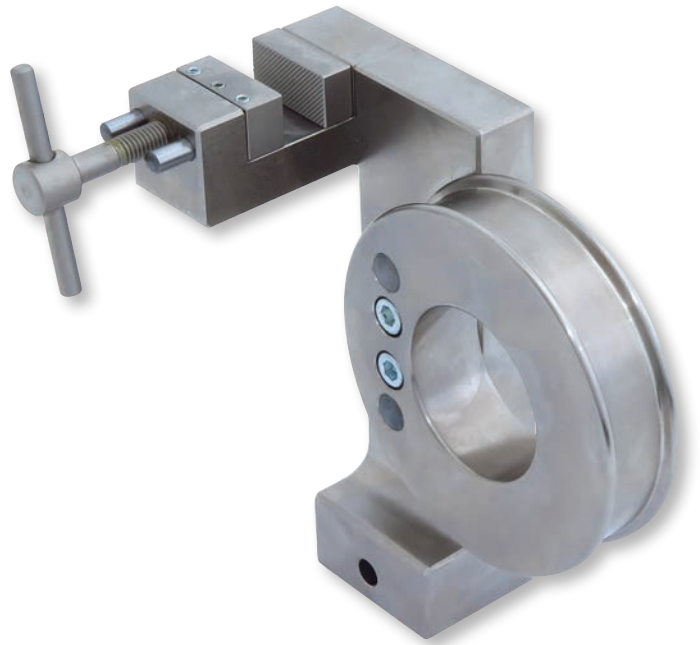

DIMENSIONS

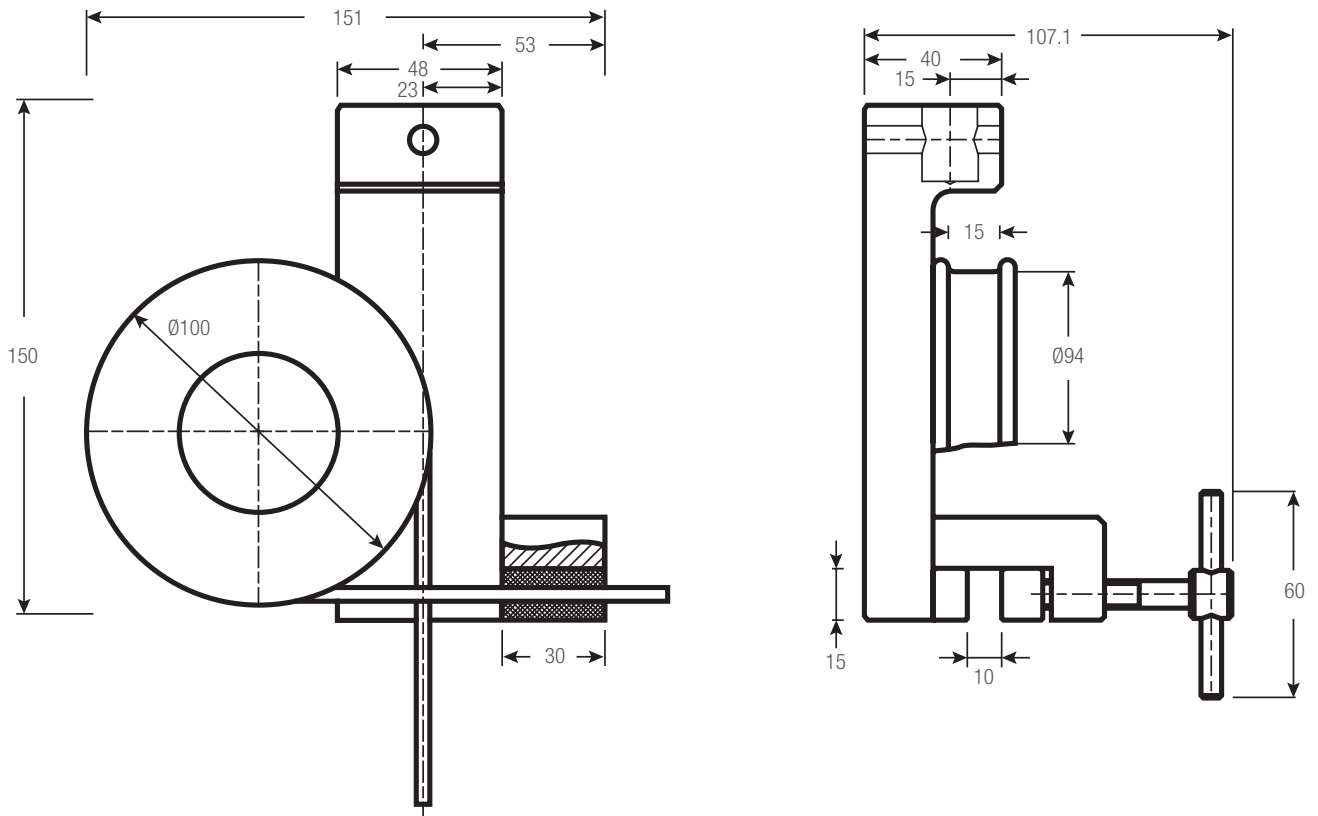

Rope Fixtures														
Model No.	Load Capacity			Jaw Face	Roller ϕ		Sample ϕ (Max)		Clamping Surface (h x w)		Weight (each)		Clevis Type	Supply
	N	KGf	LBF		in	mm	in	mm	in	mm	lbs	kgs		
ROPE-76-20S-1	20K	2,000	4,500	Serrated	3.7	94	0.4	9	1.2 x	30 x 15	6.2	2.8	15.9	2

ROPE FIXTURES

255

STEEL, NICKEL PLATED

- For general-purpose tensile testing applications
- Use on small diameter wire, rope, filaments, thread, etc.
- Operating Temperatures -94° to 662°F (-70° to 350°C)

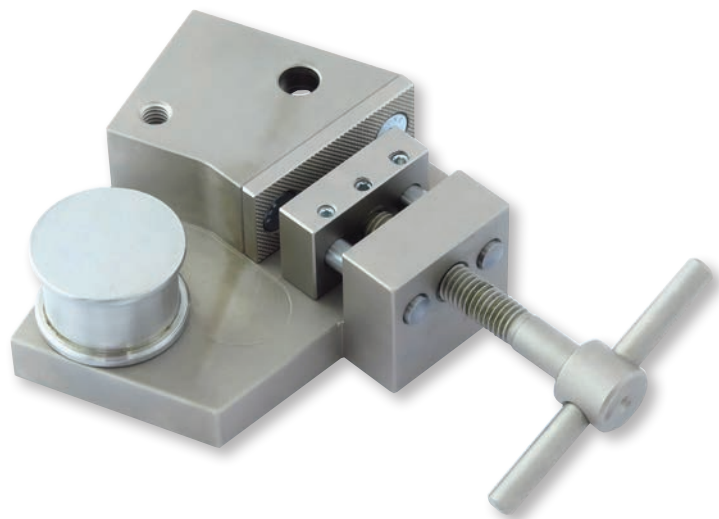

DIMENSIONS

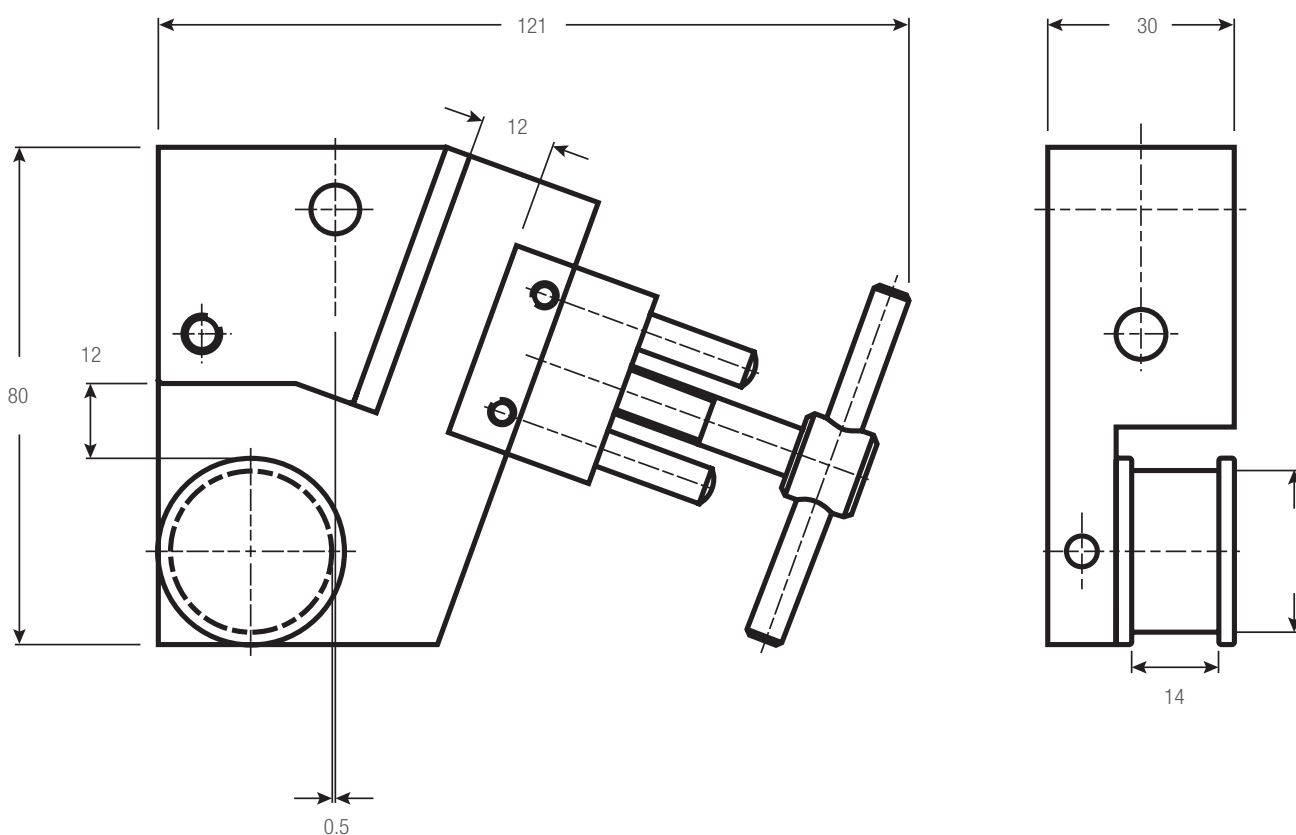

Rope Fixtures

Model No.	Load Capacity			Jaw Face	Roller ϕ		Sample ϕ (Max)		Clamping Surface (h x w)		Weight (each)		Clevis Type	Supply
	N	KGF	LBF		in	mm	in	mm	in	mm	lbs	kgs		
ROPE-255-10-PY	10K	1,000	2,200	Serrated	1.02	26	0.2	5	0.75 x 1.25	19 x 32	2.0	0.9	15.9	2
ROPE-255-10-D	10K	1,000	2,200	Diamond	1.02	26	0.2	5	0.75 x 1.25	19 x 32	2.0	0.9	15.9	2

ROPE FIXTURES

170

STEEL, NICKEL PLATED

- For general-purpose tensile testing applications
- Use on small diameter wire, rope, filaments, thread, etc.
- Operating Temperatures 32° to 662°F (0° to 130°C)



Rope Fixtures														
Model No.	Load Capacity			Jaw Face	Roller ϕ		Sample ϕ (Max)		Clamping Surface (h x w)		Weight (each)		Clevis Type mm	Supply
	N	KGf	LBF		in	mm	in	mm	in	mm	lbs	kgs		
ROPE-170-50	50K	5,000	11,000	Serrated	6.4	162	0.8	20	2.75 x 1.2	70 x 30	30.6	13.9	15.9	2

DIMENSIONS

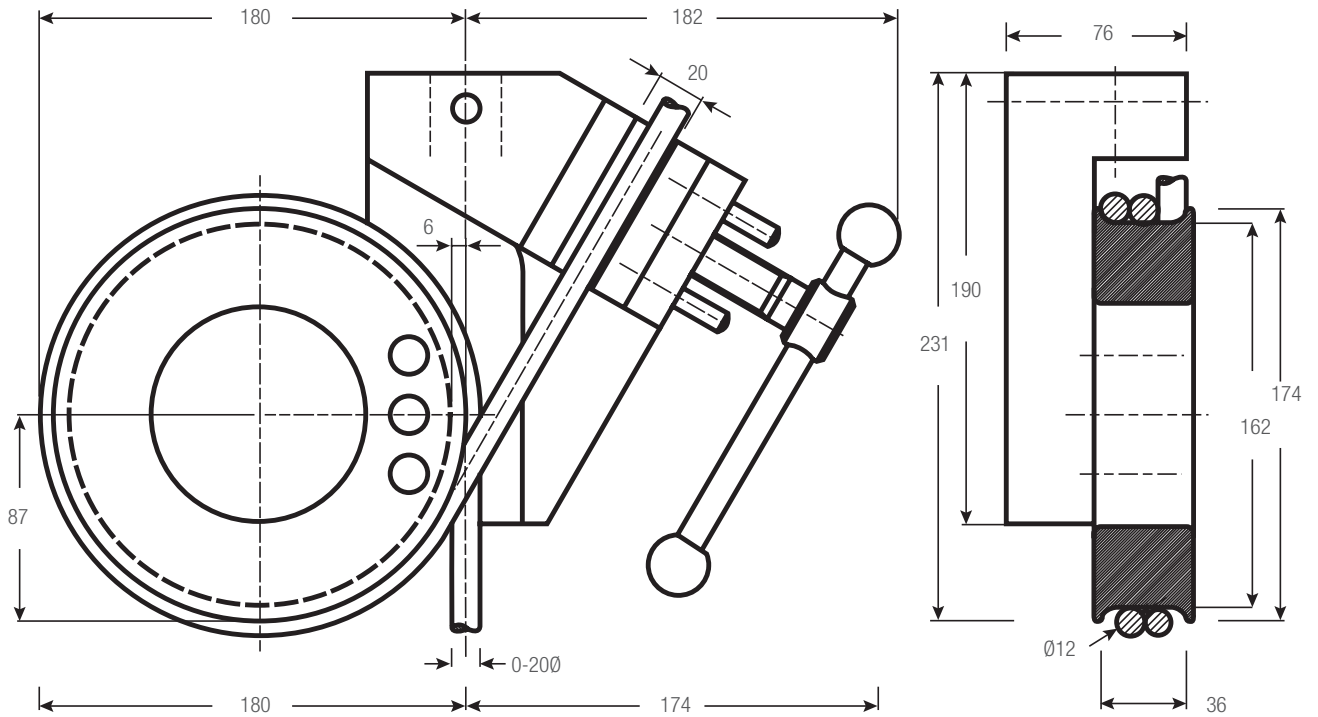

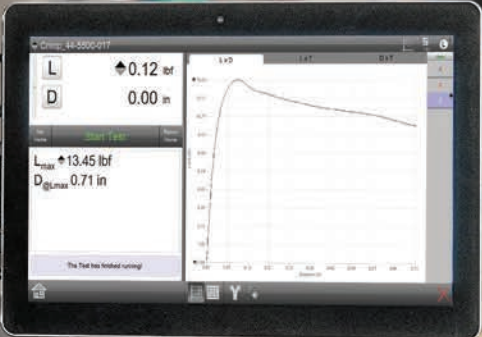

BUTTON FIXTURES

BUTTON FIXTURES

The 314 Button Fixture is designed to test the tensile strength of electrical connectors such as wire connectors that are crimped on to wires with diameters of 0.8mm, 1mm, 1.2mm, 1.6mm, 2mm, 2.4mm, 3mm, 3.2mm, 4mm, 4.8mm, 5mm and 6.4mm.

OPERATION

Rotate the body of the BUTTON-314A-1 to quickly swap between different wire gages and crimp sizes. A second grip is required to hold the opposing end of the wire, popular options include ROPE or VISE series fixtures.



Button Fixture							
Part No.	Load Capacity			Material	Diameter (mmØ)	Clevis Type (mm)	Supply Each
	N	KGF	LBF				
BUTTON-314A-1	5kN	500	1,124	Steel	1-6	15.9	1

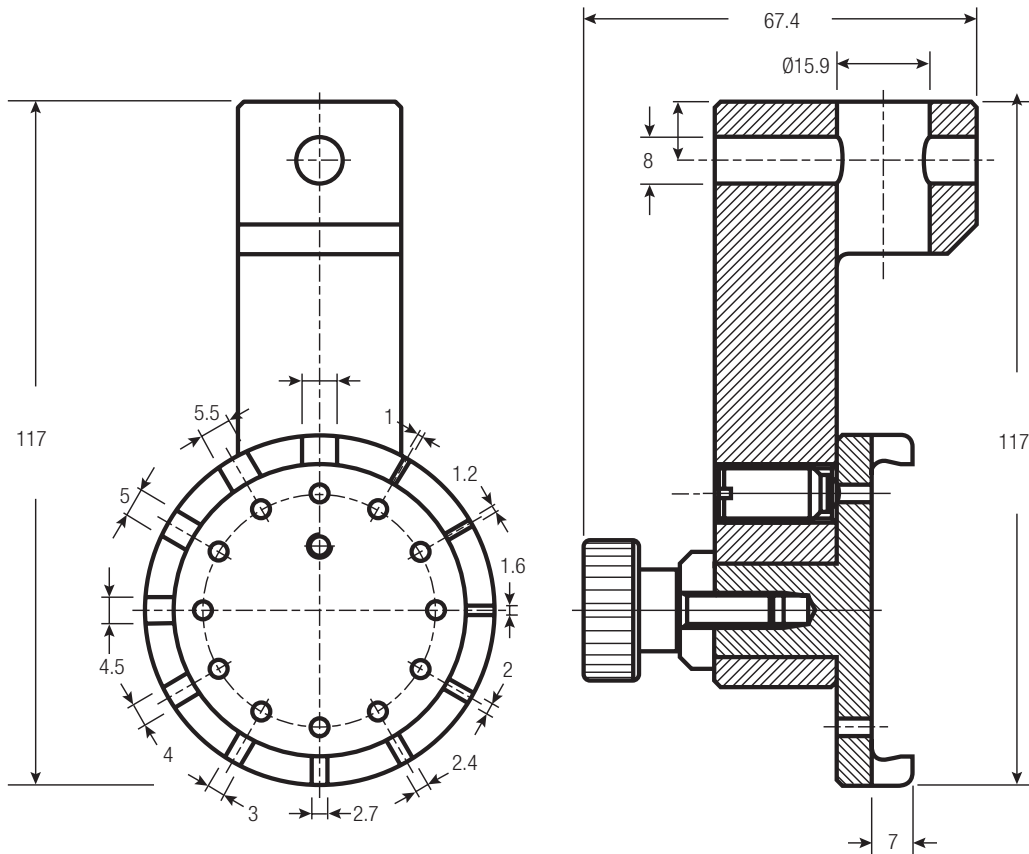



FLEXURAL FIXTURES

FLEXURAL FIXTURES

Flexural test fixtures are a relatively simple solution for determining the strength and deformation properties of materials such as wood and timber products.

Starrett can offer a variety of test fixtures and accessories for performing 3- and 4-point bend testing.

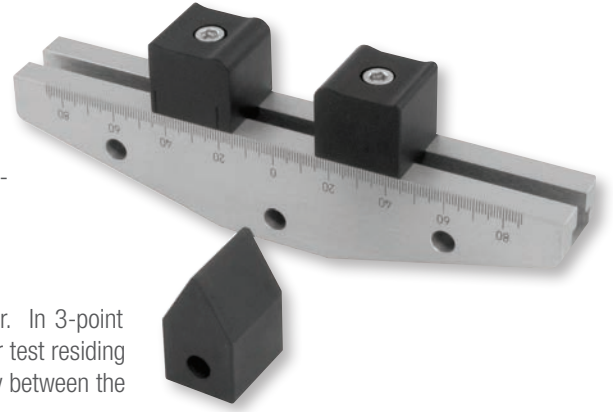

OPERATION

A beam attaches to the force testing frame, typically using a clevis adapter. In 3-point bending tests, two anvils are arranged along the beam with the sample under test residing on top of the two anvils. Force is applied in a compression direction mid-way between the two anvils for a 3-point test.

Instead of a single anvil pressing the mid-section of the sample, two anvils may be used to press down on the sample for a 4-point test.

TESTING STANDARDS

The following testing standards can be met using standard Starrett flexural testing fixtures:

- ASTM D143
- ASTM D1037
- ASTM D3037
- ISO 3133

Additional testing standards are supported. Contact your Starrett representative for more information.

BEND 3

ALUMINUM

- For general-purpose 3-point bend testing applications
- Active Span Length is 4-150mm
- Replaceable Top and Bottom Radii for 4- and 5-point applications
- Aluminum bar with anodized finish, Hardened Steel radii
- Operating Temperatures 32° to 158°F (0° to 70°C)

Bending Fixtures											
Model No.	Load Capacity			Upper Radius		Lower Radius		Weight (each)		Clevis Type mm	Supply
	N	KGF	LBF	in	mm	in	mm	lbs	kgs		
BEND-3-UR1-LR1	2,500	250	550	0.04	1.0	0.06 / 0.1	1.5 / 2.5	4.5	2.0	15.9	1
BEND-3-UR1-LR2	2,500	250	550	0.04	1.0	0.08 / 0.2	2.0 / 5.0	4.5	2.0	15.9	1
BEND-3-UR1-LR3	2,500	250	550	0.04	1.0	0.13 / 0.2	3.2 / 5.0	4.5	2.0	15.9	1
BEND-3-UR15-LR1	2,500	250	550	0.06	1.5	0.06 / 0.1	1.5 / 2.5	4.5	2.0	15.9	1
BEND-3-UR15-LR2	2,500	250	550	0.06	1.5	0.08 / 0.2	2.0 / 5.0	4.5	2.0	15.9	1
BEND-3-UR15-LR3	2,500	250	550	0.06	1.5	0.13 / 0.2	3.2 / 5.0	4.5	2.0	15.9	1
BEND-3-UR2-LR1	2,500	250	550	0.08	2.0	0.06 / 0.1	1.5 / 2.5	4.5	2.0	15.9	1
BEND-3-UR2-LR2	2,500	250	550	0.08	2.0	0.08 / 0.2	2.0 / 5.0	4.5	2.0	15.9	1
BEND-3-UR2-LR3	2,500	250	550	0.08	2.0	0.13 / 0.2	3.2 / 5.0	4.5	2.0	15.9	1
BEND-3-UR3-LR1	2,500	250	550	0.12	3.0	0.06 / 0.1	1.5 / 2.5	4.5	2.0	15.9	1
BEND-3-UR3-LR2	2,500	250	550	0.12	3.0	0.08 / 0.2	2.0 / 5.0	4.5	2.0	15.9	1
BEND-3-UR3-LR3	2,500	250	550	0.12	3.0	0.13 / 0.2	3.2 / 5.0	4.5	2.0	15.9	1
BEND-3-UR5-LR1	2,500	250	550	0.2	5.0	0.06 / 0.1	1.5 / 2.5	4.5	2.0	15.9	1
BEND-3-UR5-LR2	2,500	250	550	0.2	5.0	0.08 / 0.2	2.0 / 5.0	4.5	2.0	15.9	1
BEND-3-UR5-LR3	2,500	250	550	0.2	5.0	0.13 / 0.2	3.2 / 5.0	4.5	2.0	15.9	1

FLEXURAL FIXTURES

TOP ANVILS FOR BEND 3

HARDENED STEEL RADII

- For general-purpose 3-point bend testing applications
- Operating Temperatures 32° to 158°F (0° to 70°C)



BOTTOM SUPPORTS FOR BEND 3

HARDENED STEEL RADII

- For general-purpose 3-point bend testing applications
- Operating Temperatures 32° to 158°F (0° to 70°C)



Anvils for Bend - 3						
Model No.	Upper Radius		Weight (each)		Clevis Type mm	Supply
	in	mm	lbs	kgs		
ANVIL-10	0.04	1.0	0.5	0.2	15.9	1
ANVIL-15	0.06	1.5	0.5	0.2	15.9	1
ANVIL-20	0.08	2.0	0.5	0.2	15.9	1
ANVIL-32	0.1	3.2	0.5	0.2	15.9	1
ANVIL-50	0.2	5.0	0.5	0.2	15.9	1

Bottom Supports for Bend - 3						
Model No.	Lower Radius		Weight (each)		Clevis Type mm	Supply
	in	mm	lbs	kgs		
BASE-LR1	0.06 / 0.1	1.5 / 2.5	0.5	0.2	15.9	1
BASE-LR2	0.08 / 0.2	2.0 / 5.0	0.5	0.2	15.9	1
BASE-LR3	0.13 / 0.2	3.2 / 5.0	0.5	0.2	15.9	1

DIMENSIONS

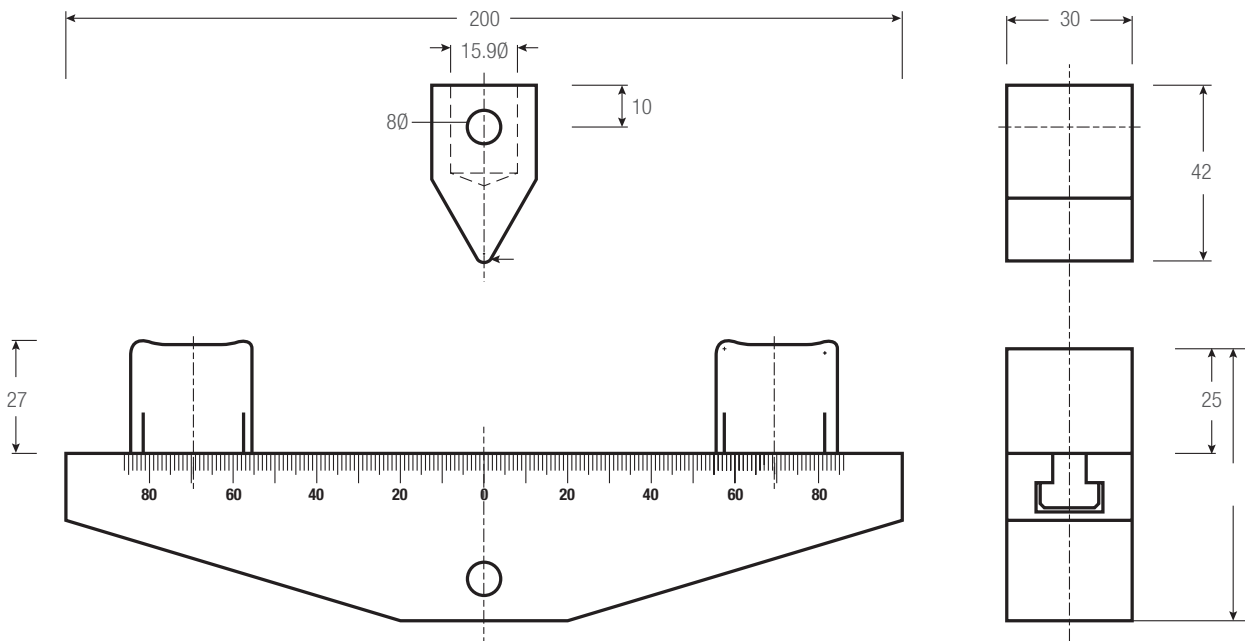



PRECISION MAKES THE DIFFERENCE

PURE PRECISION.

Introducing the HDV300 Video-based measurement system. The power of an optical comparator, meets the precision of digital video.



Starrett®

(978) 249-3551 • starrett.com

Follow us!





PEEL FIXTURES

PEEL FIXTURES

Starrett has a wide selection of test fixtures suitable for determining adhesive strength on a variety of components from adhesive tapes, thin film coatings, copper runners on electronic circuit boards and more.

OPERATION

Peel testing fixtures come in a variety of styles that match the material under test. Some include a moving table connected to the test frame's crosshead using a cable mechanism. As the crosshead moves upwards, the cables pull the table laterally to maintain a required angle. This provides a measuring of bond strength.

Other test fixtures are application specific such as a climbing drum test fixture often used in paper and paper product adhesive testing.

TESTING STANDARDS

The following testing standards can be met using standard Starrett peel testing fixtures:

- ASTM D1781
- DIN 53295
- DIN 53494
- ISO 10373

Additional testing standards are supported. Contact your Starrett representative for more information.



Peel Fixtures						
Model No.	Load Capacity			Adjustable Angle	Sample Width	Sample Length
	N	KGF	LBF			
PEEL-3-D53357B	4,000	400	900	No	60 mm	-
PEEL-3-D53357B-KL	4,000	400	900	No	90 mm	-
PEEL-3-IS06133L	4,000	400	900	No	152.4 mm	-
PEEL-50S-1	5,000	500	1,100	No	50 mm	250 mm
PEEL-50MS-1	5,000	500	1,100	Yes	50 mm	250 mm
PEEL-ASTM-D1781	5,000	500	1,100	No	80 mm	-
PEEL-104-DIN53494	7,000	700	1,570	No	30 mm	-
PEEL-105-D53289	10K	1,000	2,200	No	30 mm	-
PEEL-105-D3167	10K	1,000	2,200	No	25.4 mm	-
PEEL-192-25	10K	1,000	2,200	Yes	60mm	-
PEEL-192-22-2V	10K	1,000	2,200	No	58mm	-

PEEL FIXTURES

Ideal for adhesive testing applications or general peel testing on films, paper, foils and more. Use for 90° peel and bond strength testing methods.

The sliding table ensures a steady movement and constant peel angle so that the peel point remains in the center.

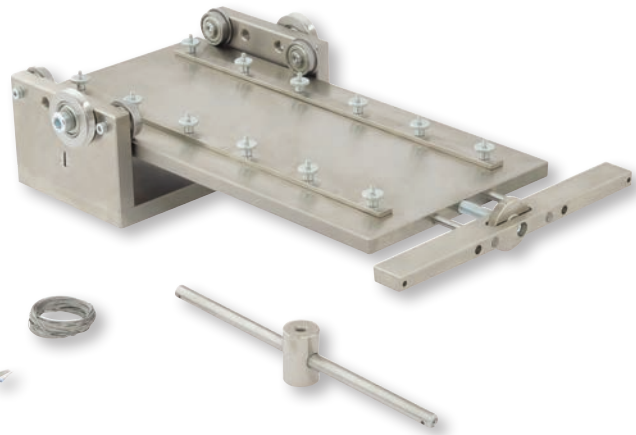

PEEL-50

STEEL, NICKEL FINISH

- For general-purpose peel and adhesive bond testing applications
- Fixed and adjustable angle platforms
- Operating Temperatures 32° to 158°F (0° to 70°C)

Shown: PEEL-50MS-1 model with adjustable angle platform.

Peel Fixtures													
Model No.	Load Capacity			Adjustable Angle	Sample Width (Max)		Sample Length (Max)		Weight (each)		Clevis Type	Supply	
	N	KGF	LBF		in	mm	in	mm	lbs	kgs			
PEEL-50S-1	5,000	500	1,100	Fixed	1.97	50	9.84	250	12.1	5.5	15.9	1	
PEEL-50MS-1	5,000	500	1,100	0-30 deg	1.97	50	9.84	250	15.9	7.2	15.9	1	

DIMENSIONS

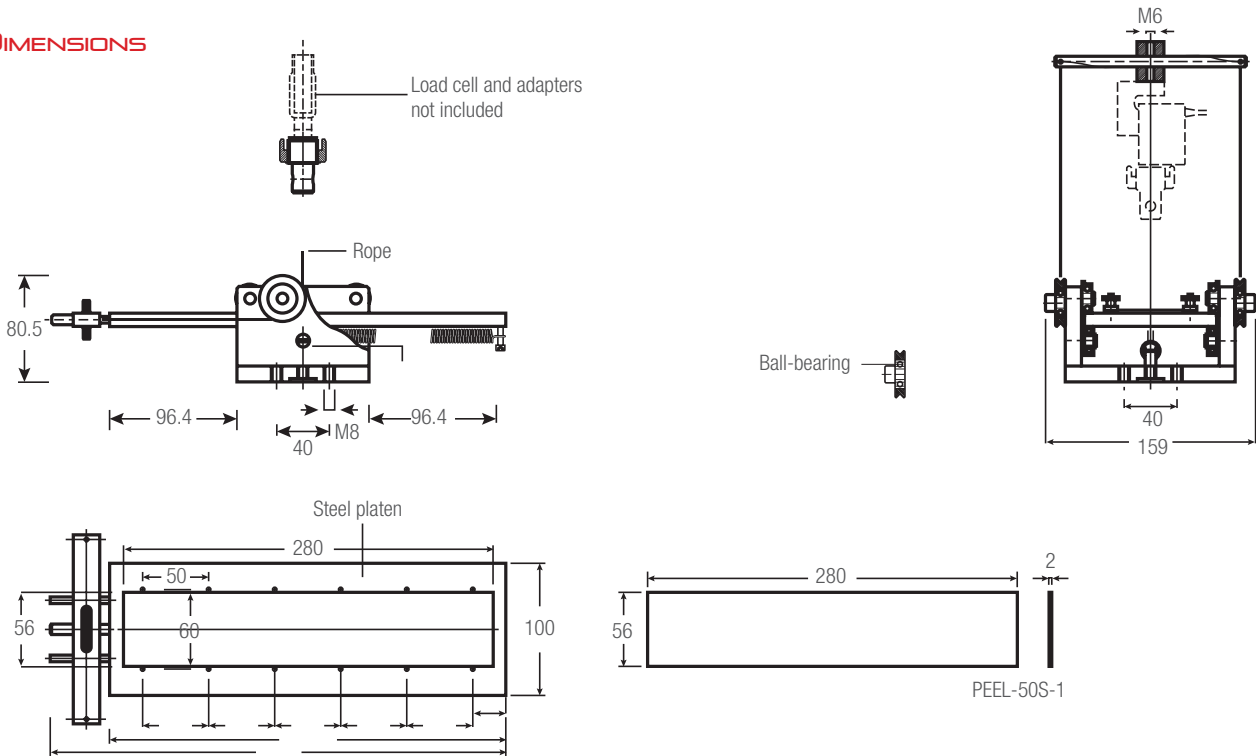

PEEL FIXTURES

The Climbing Drum fixture consists of a drum assembly, flexible loading straps mounted at the bottom of the stand, an upper self-closing clamp to grip the specimen and a drum clamp to hold the outer skin against the face of the drum.

During a test, the loading straps pull on the drum assembly, forcing it to rotate and climb along the length of the aluminum panel. This motion peels the outer skin away from the core structure. The peel force is measured indicating bond strength.

CLIMBING DRUM

STEEL, NICKEL FINISH, ALUMINUM STRAPS

- Conforms to test methods ASTM-D1781 and DIN 53295
- Operating Temperatures 32° to 266°F (0° to 130°C)



Climbing Drum Peel Fixture

Model No.	Load Capacity			Drum Diameter		Sample Width (Max)		Weight (each)		Clevis Type	Supply
	N	KGF	LBF	in	mm	in	mm	lbs	kgs		
PEEL-ASTM-D1781	5,000	500	1,100	4.02	102	3.15	80	6.6	3.0	15.9	1

DIMENSIONS

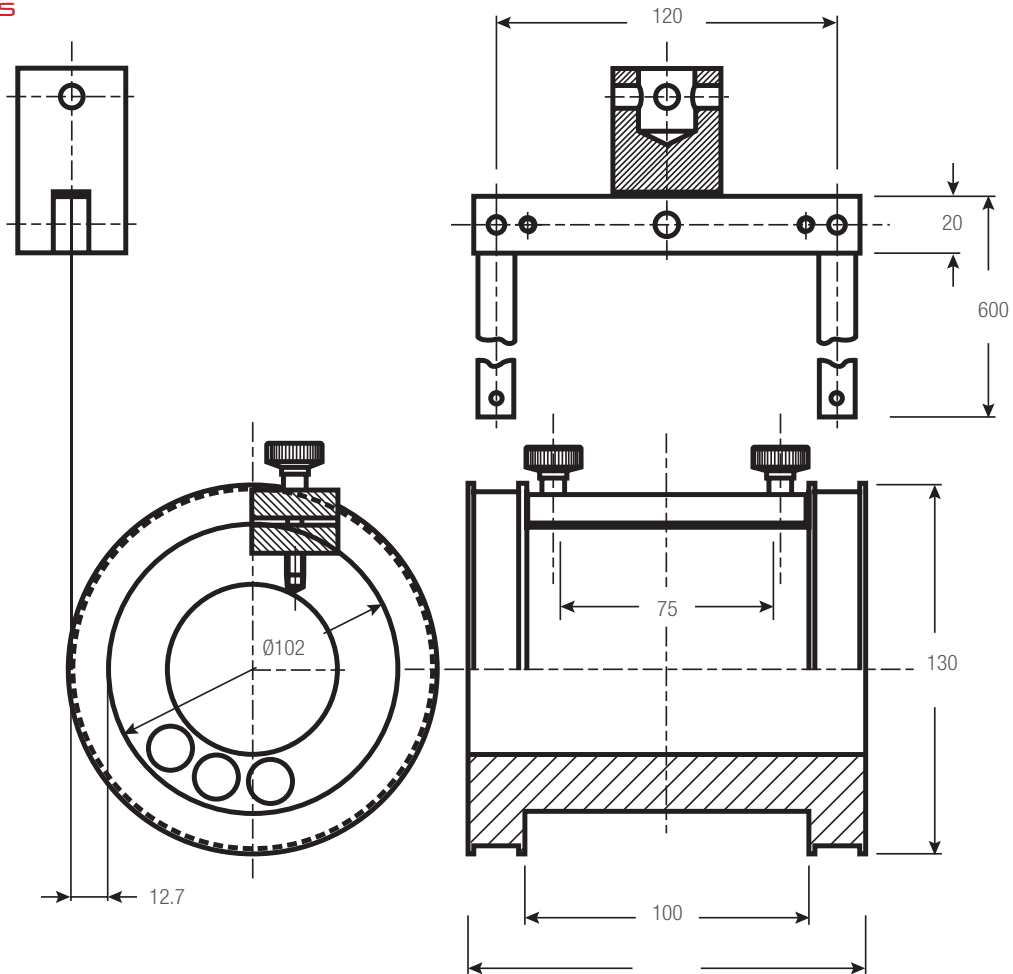

PEEL FIXTURES

104

STEEL, NICKEL FINISH

- Conforms to test methods DIN 53494, ISO 10373
- Operating Temperatures 32° to 266°F (0° to 130°C)



PEEL FIXTURES

Peel Fixture										
Model No.	Load Capacity			Sample Width (Max)		Weight (each)		Clevis Type mm	Supply	
	N	KGF	LBF	in	mm	lbs	kgs			
PEEL-104-DIN53494	7,000	700	1,570	1.2	30	2.2	1.0	15.9	1	

DIMENSIONS

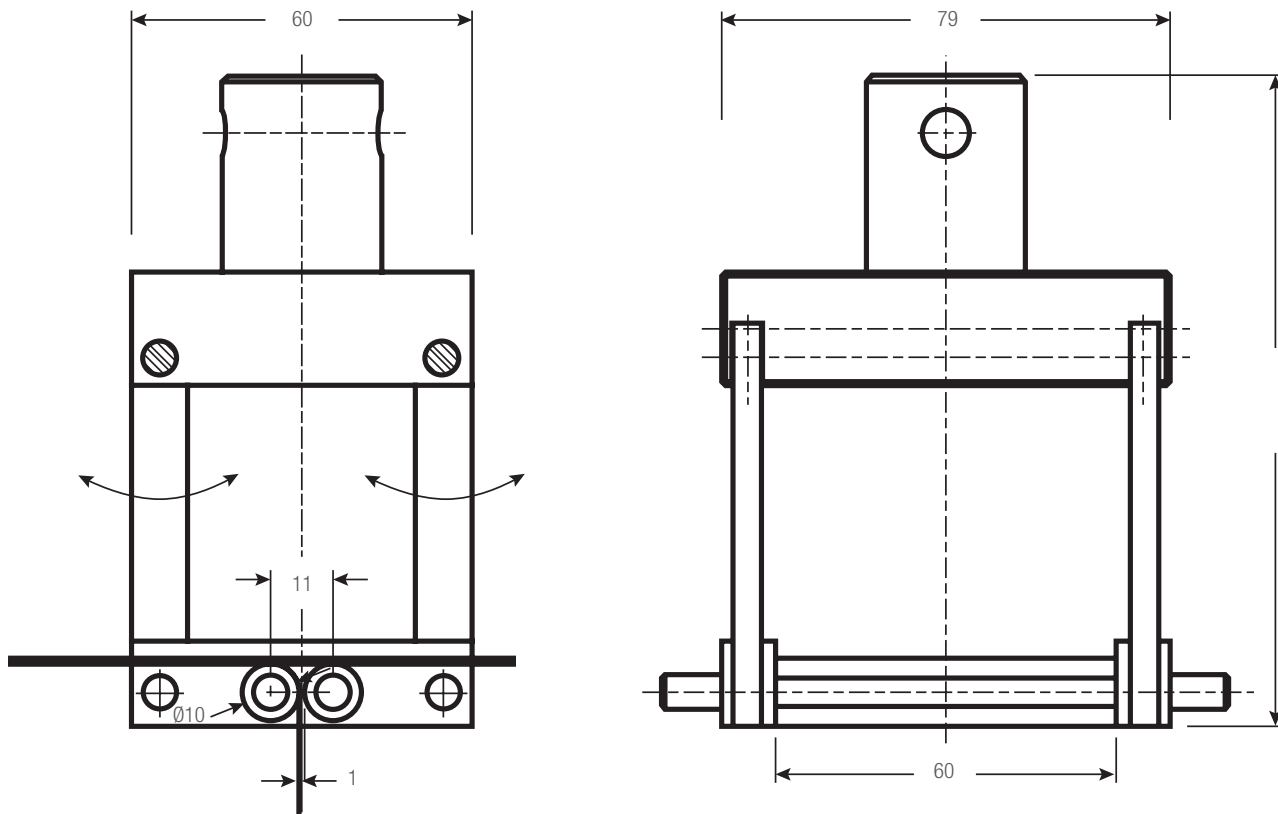

PEEL FIXTURES

105

STEEL, NICKEL FINISH

- Conforms to test methods ASTM D3167, DIN 53289, ISO 4578
- Operating Temperatures 32° to 158°F (0° to 70°C)
- Additional lower grip is required

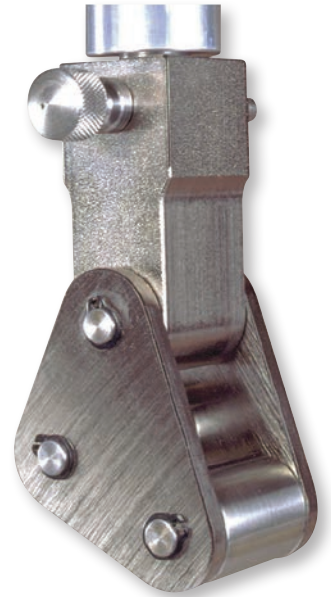

Peel Fixture											
Model No.	Load Capacity			Roller Diameter		Sample Width (Max)		Weight (each)		Clevis Type	Supply
	N	KGF	LBF	in	mm	in	mm	lbs	kgs	mm	
PEEL-105-D53289	10K	1,000	2,200	0.98	25	1.2	30	1.3	0.6	15.9	1
PEEL-105-D3167	10K	1,000	2,200	1.0	25.4	1.0	25.4	1.5	0.7	15.9	1

DIMENSIONS

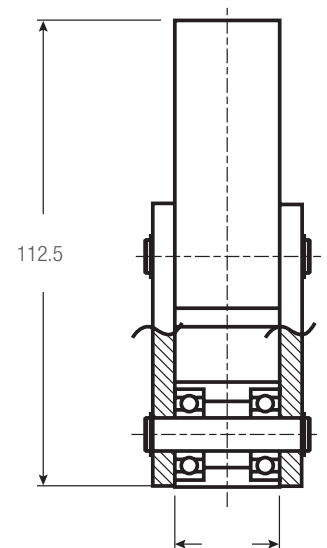
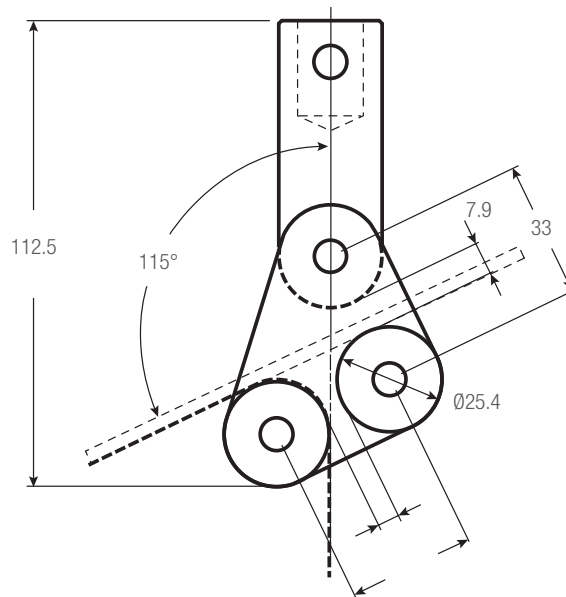
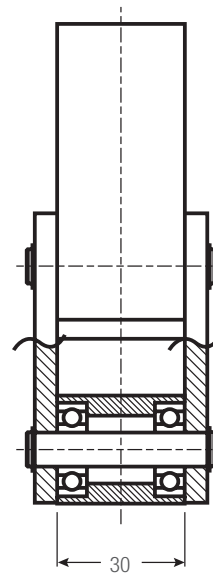
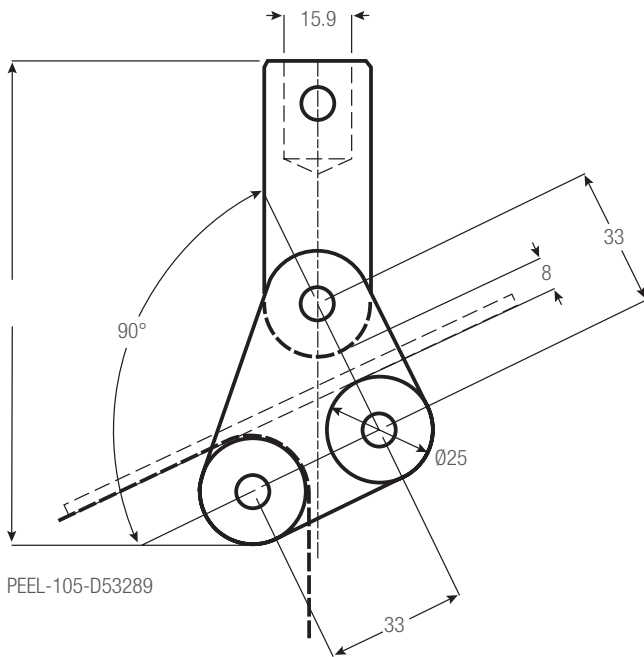

PEEL FIXTURES

PEEL 3

ALUMINUM, ANODIZED FINISH

- Used to test bond strength of tape, plastic, paper films, laminated release coatings
- 90-degree peel angle testing
- Conforms to DIN 53357B, ISO 6133
- Operating Temperatures 32° to 158°F (0° to 70°C)
- Additional lower grip is required



PEEL-3-D53357B-KL

PEEL-3-ISO6133L

Peel Fixture											
Model No.	Load Capacity			Roller Diameter		Sample Width (Max)		Weight (each)		Clevis Type	Supply
	N	KGF	LBF	in	mm	in	mm	lbs	kgs	mm	
PEEL-3-D53357B	4,000	400	900	3.5	90	2.4	60	4.4	2.0	15.9	1
PEEL-3-D53357B-KL	4,000	400	900	3.5	90	2.4	60	4.6	2.1	15.9	1
PEEL-3-ISO6133L	4,000	400	900	6.0	152.4	2.4	60	7.3	3.3	15.9	1

DIMENSIONS

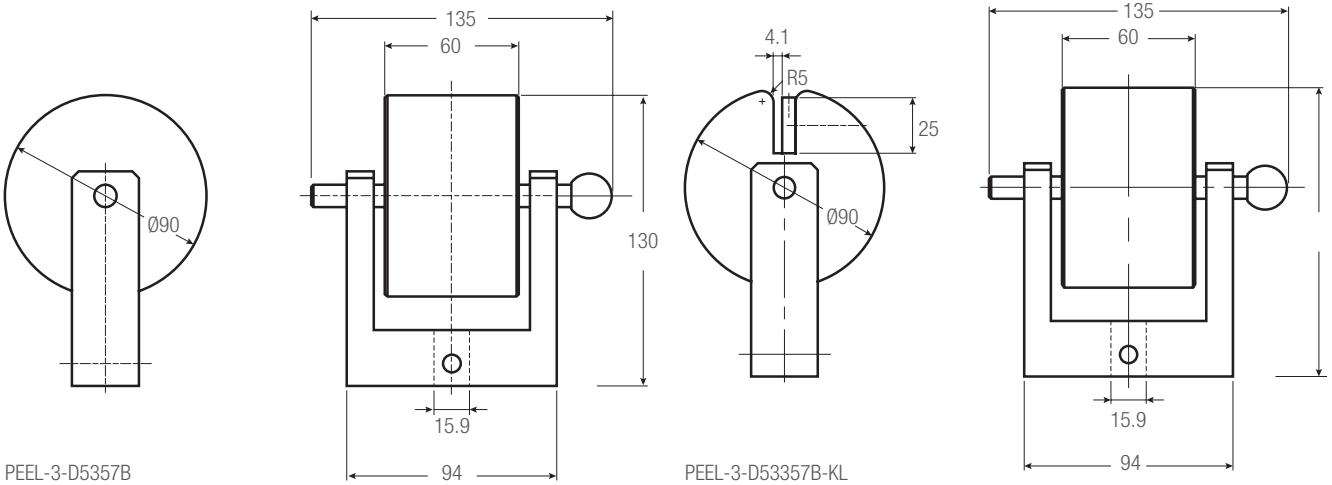

PEEL-3-D5357B

PEEL-3-D53357B-KL

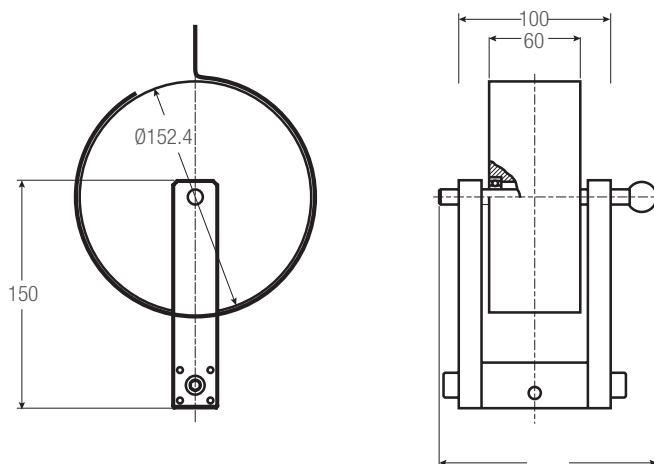

PEEL FIXTURES

192

STEEL, NICKEL FINISH

- Conforms to test methods DIN 1464
- Adjustable cylinder angle 0-45° or width to 50mm
- Operating Temperatures 32° to 158°F (0° to 70°C)
- Additional lower grip is required



Peel Fixture													
Model No.	Load Capacity			Cylinder Type	Roller Diameter		Sample Width (Max)		Weight (each)		Clevis Type	Supply	
	N	KGF	LBF		in	mm	in	mm	lbs	kgs			
PEEL-192-25	10K	1,000	2,200	Adjusts 0-45°	0.98	25	2.4	60	2.2	1.0	15.9	1	
PEEL-192-22-2V	10K	1,000	2,200	Adjusts 0-50mm	0.87	22	2.3	58	3.6	1.65	15.9	1	

DIMENSIONS

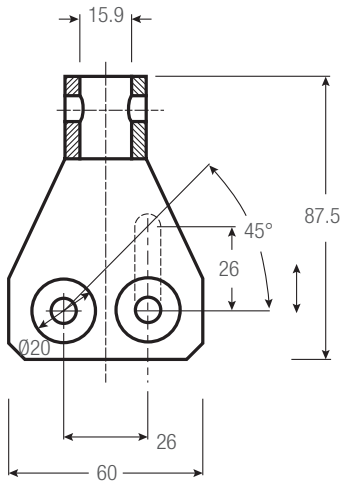

PEEL-192-25

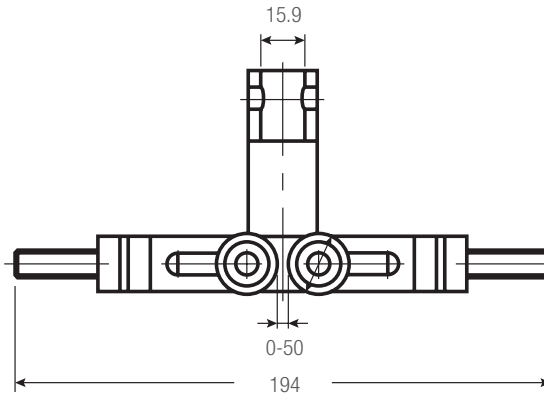
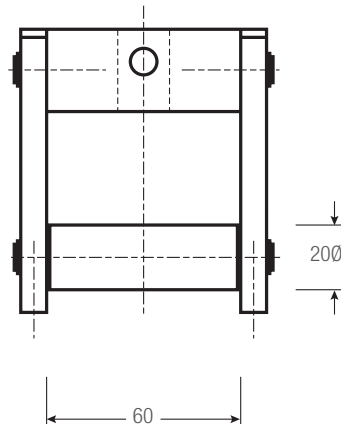

PEEL-192-22v

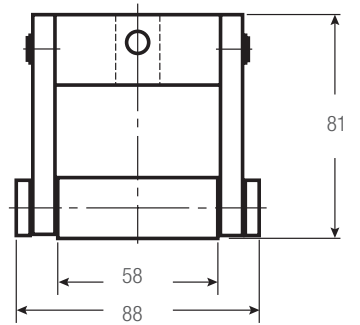



PNEUMATIC FIXTURES

PNEUMATIC FIXTURES

Starrett pneumatic test fixtures use pneumatic actuation to open and close the jaws on the test fixture. Single and dual actuation are available for most test fixtures. These fixtures may be controlled using a handswitch or foot switch and are ideal for high-volume testing application. Accessories including an air compressor, tubing, regulator and switches are available.

OPERATION

Pneumatic-actuated test fixtures are ideal for high-volume testing. Air pressure is used to open and close the test fixture's jaws. The opening or closing of the jaws may be done using a foot switch kit or hand switch kit.

TESTING STANDARDS

There are a variety of testing standards that can be used with pneumatic-actuated test fixtures. Contact your Starrett representative for more information about your specific testing method and the available test fixtures.



Model No.	Load Capacity			Actuation	Jaw Opening Max
	N	KGF	LBF		
PNEUM-9+KO	2.5kN	250	562	Single	Jaw Dependant
PNEUM-9+2KO	2.5kN	250	562	Dual	Jaw Dependant
PNEUM-140K+KO	100	10	22	Single	Jaw Dependant
PNEUM-140K+2KO	100	10	22	Dual	Jaw Dependant
PNEUM-94A-1	200	20	45	Single	Jaw Dependant
PNEUM-229A-1	1kN	100	225	Single	Jaw Dependant
PNEUM-56KA-1	1,200	120	270	Single	Jaw Dependant
PNEUM-56K2KA-1	1,200	120	270	Dual	Jaw Dependant
PNEUM-56GKA-1	2.5kN	250	562	Single	Jaw Dependant
PNEUM-56G2KA-1	2.5kN	250	562	Dual	Jaw Dependant
PNEUM-56GHKA-1	2.5kN	250	562	Single	Jaw Dependant
PNEUM-56GH2KA-1	2.5kN	250	562	Dual	Jaw Dependant
PNEUM-240KA-1	2.5kN	250	562	Single	10 mm
PNEUM-2402KA-1	2.5kN	250	562	Dual	10 mm
PNEUM-240KA-20-1	1kN	100	225	Single	20 mm
PNEUM-2402KA-20-1	1kN	100	225	Dual	20 mm
PNEUM-240KA-30-1	1kN	100	225	Single	30 mm
PNEUM-2402KA-30-1	1kN	100	225	Dual	30 mm
PNEUM-240KA-50-1	1kN	100	225	Single	50 mm
PNEUM-2402KA-50-1	1kN	100	225	Dual	50 mm
PNEUM-240G+KO	2,600	260	585	Single	Jaw Dependant
PNEUM-240G+2KO	2,600	260	585	Dual	Jaw Dependant
PNEUM-83A-1	7kN	700	1,575	Single	Jaw Dependant
PNEUM-108A-1	3,500	350	785	Single	Jaw Dependant
PNEUM-126A-1	30kN	3,000	6,750	Single	Jaw Dependant
PNEUM-149A-1	2.4kN	240	540	Dual	Jaw Dependant
PNEUM-232A-1	16kN	1,600	3,600	Single	Jaw Dependant
PNEUM-22-S60	2,000	200	450	Dual	Jaw Dependant
PNEU-13G	5kN	500	1,124	Single	3 mm
PNEU-13G+BD	5kN	500	1,124	Single	3 mm
PNEU-13K	200	20	45	Single	1 mm
PNEU-13K+BD	200	20	45	Single	1 mm
PNEU-13M	2kN	200	450	Single	2 mm
PNEU-13M-BD	2kN	200	450	Single	2 mm
PNEUM-501A-1	2,000	200	450	Dual	6mm
PNEUM-76-5+KO	5kN	500	1,124	Single	6mm

PNEUMATIC FIXTURES

9P

ALUMINUM, ANODIZED

- Vise-action, general purpose test fixture for tensile applications
- Single and Dual actuation models
- Order required jaw set separately
- Operating Temperatures 32° to 158°F (0° to 70°C)

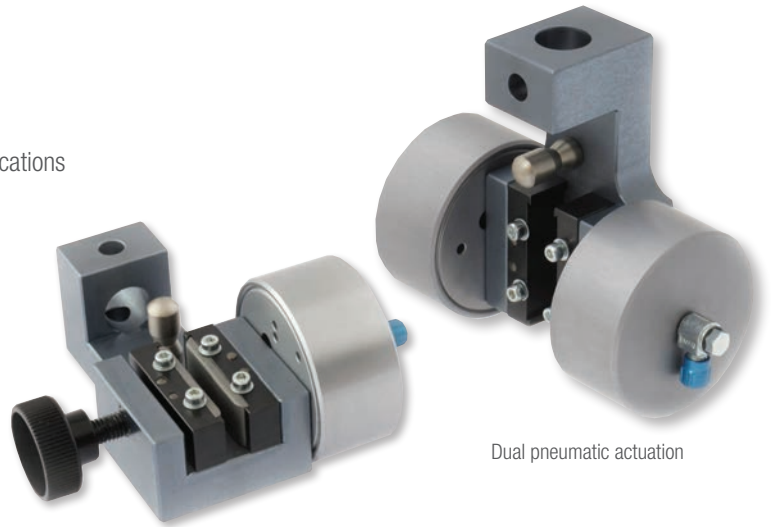

Dual pneumatic actuation

Pneumatic Fixtures													
Model No.	Load Capacity			Pneumatic Actuation	Jaw Face	Jaw Opening (Max)		Clamping Surface		Weight (each)		Clevis Type mm	Supply
	N	KGf	LBF			in	mm	in	mm	lbs	kgs		
PNEUM-9+KO	2,500	250	562	Single	No Jaws	Jaw Dependent		Jaw Dependent		1.2	0.56	15.9	2
PNEUM-9+2KO	2,500	250	562	Dual	No Jaws	Jaw Dependent		Jaw Dependent		1.6	0.74	15.9	2

DIMENSIONS

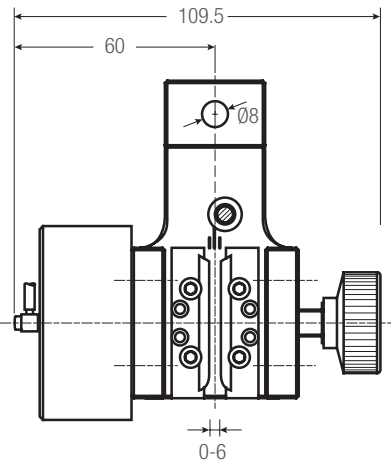

PNEUM-9+KO

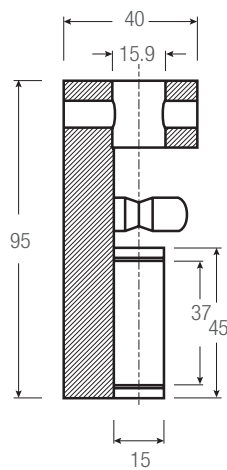

PNEUM-9+2KO

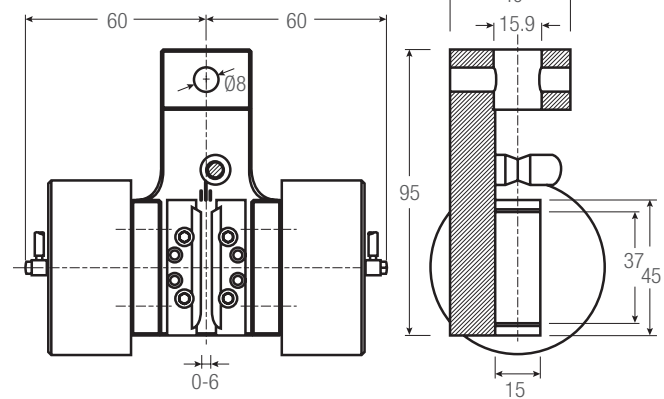

9 JAW SETS

STEEL, HARDENED

- Supplied four (4) jaws per set
- Operating Temperatures 32° to 266°F (0° to 130°C)

Jaw Sets					
Model No.	Jaw Face	Jaw Opening (Max)		Clamping Surface	
		in	mm	in	mm
JAW9-B15	Smooth	0.2	6	1.5 x 0.6	37 x 15
JAW9-D15	Diamond	0.2	6	1.5 x 0.6	37 x 15

SMOOTH JAW

- Suitable for own further treatments
- Steel-blanks without coating

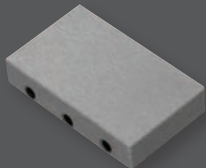

DIAMOND-COATED JAW

- Clamping surface coated with synthetic diamonds
- Nickel-plated

PNEUMATIC FIXTURES

140P

ALUMINUM, ANODIZED

- Vise-action, general purpose test fixture for tensile applications
- Single and Dual actuation models
- Operating Temperatures 32° to 158°F (0° to 70°C)

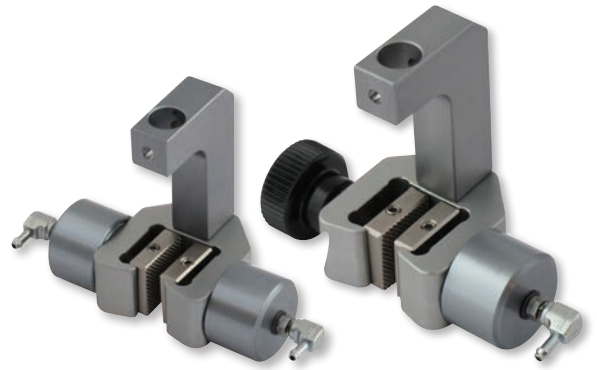

Pneumatic Fixtures													
Model No.	Load Capacity			Pneumatic Actuation	Jaw Face	Jaw Opening (Max)		Clamping Surface		Weight (each)		Clevis Type	Supply
	N	KGf	LBF			in	mm	in	mm	lbs	kgs		
PNEUM-140K+KO	100	10	22	Single	No Jaws	Jaw Dependent		Jaw Dependent		1.6	0.73	15.9	2
PNEUM-140K+2KO	100	10	22	Dual	No Jaws	Jaw Dependent		Jaw Dependent		2.1	0.94	15.9	2

DIMENSIONS

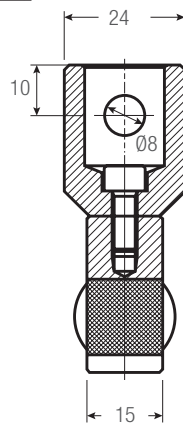
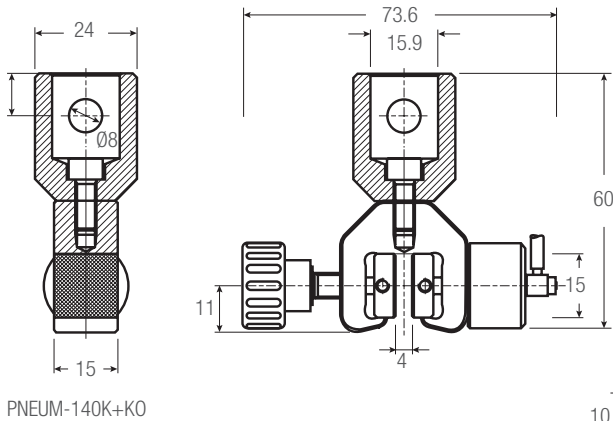

140 JAW SETS

STEEL, HARDENED

- Supplied four (4) jaws per set
- Operating Temperatures 32° to 266°F (0° to 130°C)

Jaw Sets					
Model No.	Jaw Face	Jaw Opening (Max)		Clamping Surface	
		in	mm	in	mm
JAW140-B	Smooth	0.3	8	0.6 x 0.6	15 x 15
JAW140-BR	Rubber	0.2	6	0.6 x 0.6	15 x 15
JAW140-PV	Serrated	0.3	8	0.6 x 0.6	15 x 15

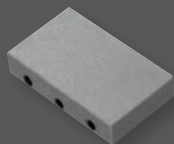

SMOOTH JAW

- Suitable for own further treatments
- Steel-blanks without coating

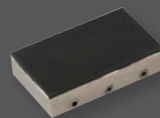

RUBBER-COATED JAW

- 1mm rubber coating (NBR)
- Nickel-plated

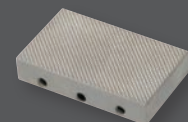

SERRATED JAW

- Pyramids 1.2 x 45°
- Hardened steel 58HRC
- Nickel-plated

PNEUMATIC FIXTURES

94P

ALUMINUM, ANODIZED

- Vise-action, general purpose test fixture for tensile applications
- Single and Dual actuation models
- Operating Temperatures 32° to 158°F (0° to 70°C)



Pneumatic Fixtures													
Model No.	Load Capacity			Pneumatic Actuation	Jaw Face	Jaw Opening (Max)		Clamping Surface		Weight (each)		Clevis Type	Supply
	N	KGF	LBF			in	mm	in	mm	lbs	kgs		
PNEUM-94A-1	200	20	45	Single	No Jaws	Jaw Dependent	Jaw Dependent	Jaw Dependent	Jaw Dependent	0.5	0.24	15.9	2

DIMENSIONS

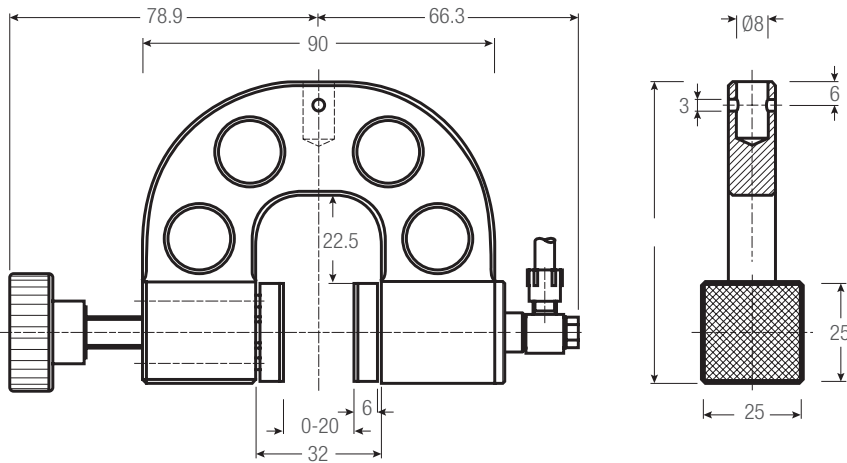

Note: Supplied with 15.9 clevis adapter

94 JAW SETS

STEEL, HARDENED

- Supplied four (4) jaws per set
- Operating Temperatures 32° to 266°F (0° to 130°C)

Jaw Sets					
Model No.	Jaw Face	Jaw Opening (Max)		Clamping Surface	
		in	mm	in	mm
JAW94-B25	Smooth	0.8	20	0.98 x 0.98	25 x 25
JAW94-BR25	Rubber	0.7	18	0.98 x 0.98	25 x 25
JAW94-PY25	Serrated	0.8	20	0.98 x 0.98	25 x 25
JAW94-D25	Diamond	0.8	20	0.98 x 0.98	25 x 25
JAW94-B50	Smooth	0.8	20	0.98 x 1.97	25 x 50
JAW94-BR50	Rubber	0.7	18	0.98 x 1.97	25 x 50
JAW94-PY50	Serrated	0.8	20	0.98 x 1.97	25 x 50
JAW94-WV50	Wave	0.63	16	0.98 x 1.97	25 x 50
JAW94-D50	Diamond	0.8	20	0.98 x 1.97	25 x 50

SMOOTH JAW

- Suitable for own further treatments
- Steel-blanks without coating

RUBBER-COATED JAW

- 1mm rubber coating (NBR)
- Nickel-plated

SERRATED JAW

- Pyramids 1.2 x 45°
- Hardened steel 58HRC
- Nickel-plated

WAVE JAW

- For flexible materials
- Wave 5mm
- Hardened steel 58HRC
- Nickel-plated

DIAMOND-COATED JAW

- Clamping surface coated with synthetic diamonds
- Nickel-plated

PNEUMATIC FIXTURES

229P

ALUMINUM, ANODIZED

- Vise-action, general purpose test fixture for tensile applications
- Single and Dual actuation models
- Operating Temperatures 32° to 158°F (0° to 70°C)

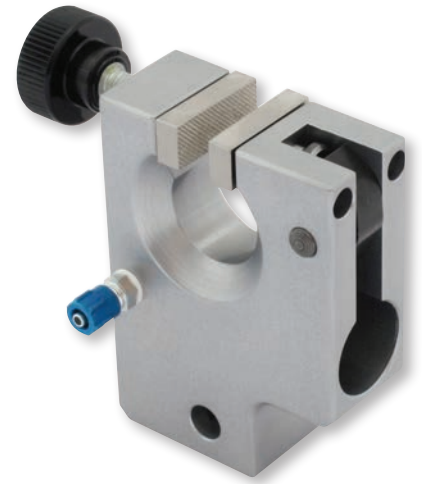

Pneumatic Fixtures

Model No.	Load Capacity			Pneumatic Actuation	Jaw Face	Jaw Opening (Max)		Clamping Surface		Weight (each)		Clevis Type	Supply
	N	KGF	LBF			in	mm	in	mm	lbs	kgs		
PNEUM-229A-1	1,000	100	225	Single	No Jaws	Jaw Dependent		Jaw Dependent		0.6	0.25	15.9	2

DIMENSIONS

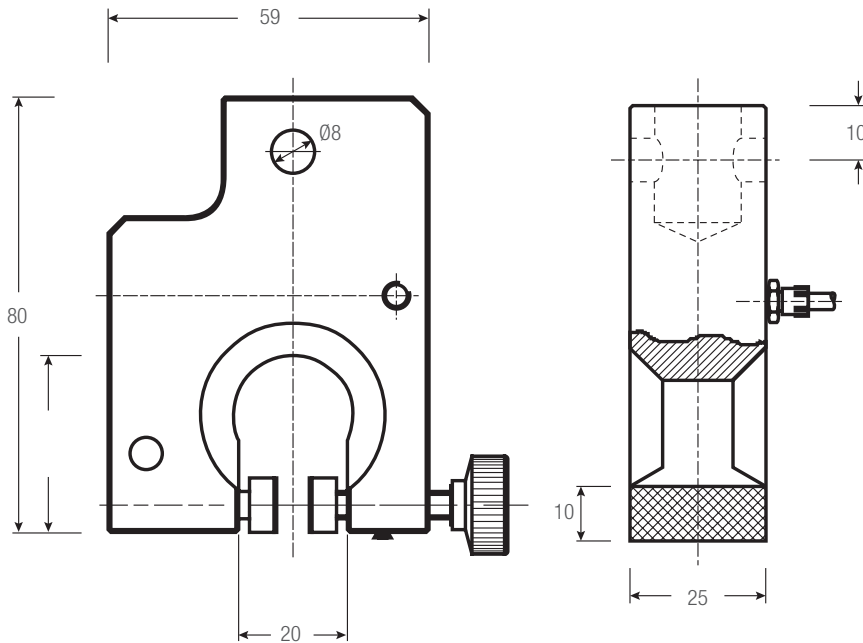

229 JAW SETS

STEEL, HARDENED

- Supplied four (4) jaws per set
- Operating Temperatures 32° to 266°F (0° to 130°C)

Jaw Sets

Model No.	Jaw Face	Jaw Opening (Max)		Clamping Surface	
		in	mm	in	mm
JAW229-B25	Smooth	0.3	8	0.4 x 0.98	10 x 25
JAW229-BR25	Rubber	0.2	6	0.4 x 0.98	10 x 25
JAW229-PY25	Serrated	0.3	8	0.4 x 0.98	10 x 25
JAW229-D25	Diamond	0.3	8	0.4 x 0.98	10 x 25
JAW229-B50	Smooth	0.2	6	0.4 x 1.97	10 x 50
JAW229-BR50	Rubber	0.15	4	0.4 x 1.97	10 x 50
JAW229-PY50	Serrated	0.2	6	0.4 x 1.97	10 x 50
JAW229-D50	Diamond	0.2	6	0.4 x 1.97	10 x 50
JAW229-B100	Smooth	0.2	6	0.4 x 3.94	10 x 100
JAW229-BR100	Rubber	0.15	4	0.4 x 3.94	10 x 100
JAW229-PY100	Serrated	0.2	6	0.4 x 3.94	10 x 100
JAW229-D100	Diamond	0.2	6	0.98 x 1.97	10 x 100

SMOOTH JAW

- Suitable for own further treatments
- Steel-blanks without coating

RUBBER-COATED JAW

- 1 mm rubber coating (NBR)
- Nickel-plated

SERRATED JAW

- Pyramids 1.2 x 45°
- Hardened steel 58HRC
- Nickel-plated

DIAMOND-COATED JAW

- Clamping surface coated with synthetic diamonds
- Nickel-plated

PNEUMATIC FIXTURES

56KP

ALUMINUM, ANODIZED

- For general-purpose tensile testing applications
- Dual-action tightening from both sides
- Order required jaw set separately
- Operating Temperatures 32° to 158°F (0° to 70°C)

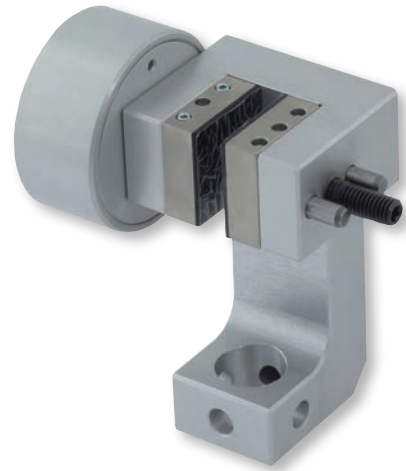

Pneumatic Fixtures													
Model No.	Load Capacity			Pneumatic Actuation	Jaw Face	Jaw Opening (Max)		Clamping Surface		Weight (each)		Clevis Type mm	Supply
	N	KGF	LBF			in	mm	in	mm	lbs	kgs		
PNEUM-56KA-1	1,200	120	265	Single	No Jaws	Jaw Dependent	Jaw Dependent	Jaw Dependent	Jaw Dependent	2.2	1.0	15.9	2
PNEUM-56K2KA-1	1,200	120	265	Dual	No Jaws	Jaw Dependent	Jaw Dependent	Jaw Dependent	Jaw Dependent	3.1	1.4	15.9	2

DIMENSIONS

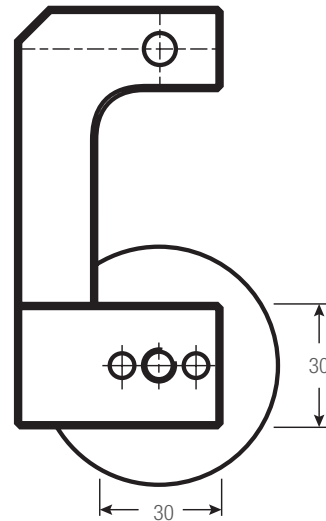
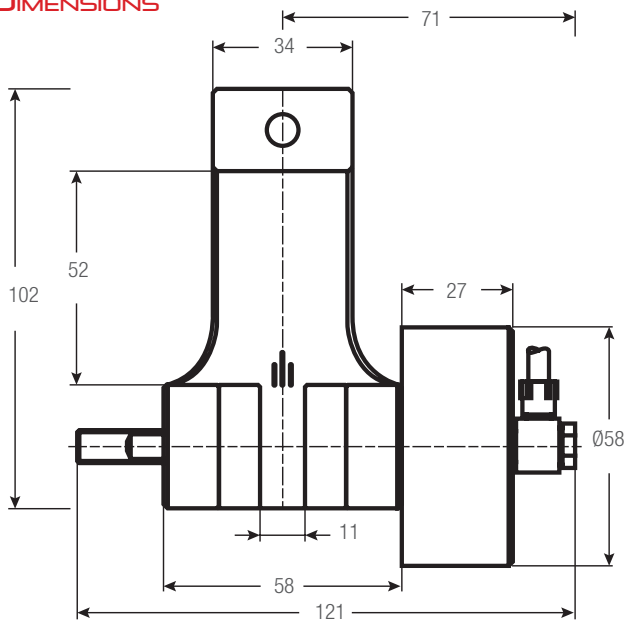

PNEUM-56KA-1

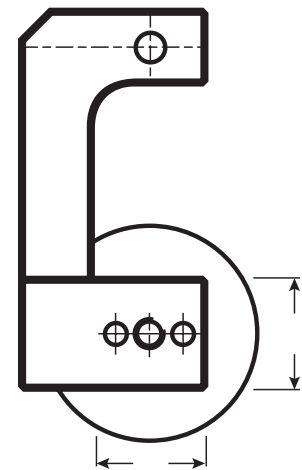
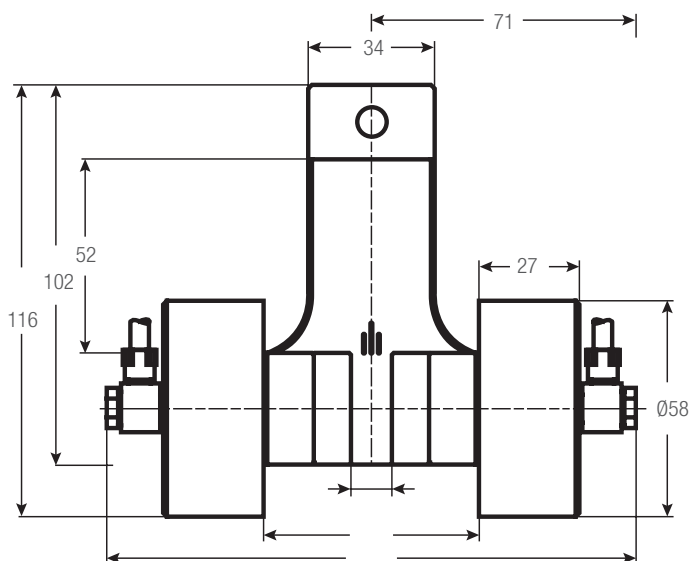

PNEUMATIC FIXTURES

56K JAW SETS

STEEL, HARDENED

- Supplied four (4) jaws per set
- Operating Temperatures 32° to 266°F (0° to 130°C)

Jaw Sets					
Model No.	Jaw Face	Jaw Opening (Max)		Clamping Surface	
		in	mm	in	mm
JAW56K-B30	Smooth	0.4	10	1.18 x 1.18	30 x 30
JAW56K-BR30	Rubber	0.2	8	1.18 x 1.18	30 x 30
JAW56K-PY30	Serrated	0.4	10	1.18 x 1.18	30 x 30
JAW56K-V2	V-notch	0.08-0.4 ϕ	2-10 ϕ	1.18 x 1.18	30 x 30
JAW56K-V3	V-notch	0.12-0.4 ϕ	3-10 ϕ	1.18 x 1.18	30 x 30
JAW56K-WV30	Wave	0.4	10	1.18 x 1.18	30 x 30
JAW56K-D30	Diamond	0.4	10	1.18 x 1.18	30 x 30

OPTIONAL CARRIER AND CARRIER SETS

STEEL, HARDENED

- Supplied four (4) jaws per set
- Operating Temperatures 32° to 266°F (0° to 130°C)
- Quick Change jaw sets requires both CARRIER-56K and CAR56K

Carrier Sets							
Model No.	Material	Face	Jaw Dimensions (h x w)		Opening Width (h x w)		Supply each
			in	mm	in	mm	
CARRIER-56K	Steel	-	-	-	-	-	4
CAR56K-B36	Steel	Smooth	1.18 x 1.18	30 x 30	0 - 0.3	0 - 8	4
CAR56K-BR36	Steel	Rubber	1.18 x 1.18	30 x 30	0 - 0.2	0 - 6	4
CAR56K-D36	Steel	Diamond	1.18 x 1.18	30 x 30	0 - 0.3	0 - 8	4
CAR56K-PY36	Steel	Serrated	1.18 x 1.18	30 x 30	0 - 0.3	0 - 8	4

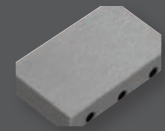

SMOOTH JAW

- Suitable for own further treatments
- Steel-blanks without coating

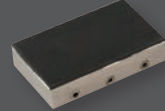

RUBBER-COATED JAW

- 1mm rubber coating (NBR)
- Nickel-plated

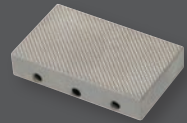

SERRATED JAW

- Pyramids 1.2 x 45°
- Hardened steel 58HRC
- Nickel-plated

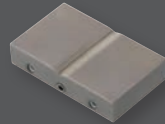

V-NOTCH JAW

- For all kinds of round samples
- Tooth pitch 1.2 mm
- Hardened steel
- Nickel-plated

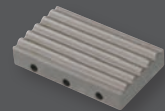

WAVE JAW

- For flexible materials
- Wave 5mm
- Hardened steel 58HRC
- Nickel-plated

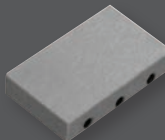

DIAMOND-COATED JAW

- Clamping surface coated with synthetic diamonds
- D91 (170/200 mesh)
- Nickel-plated

PNEUMATIC FIXTURES

56GP

ALUMINUM, ANODIZED

- For general-purpose tensile testing applications
- Dual-action tightening from both sides
- Order required jaw set separately
- Operating Temperatures 32° to 158°F (0° to 70°C)



PNEUMATIC FIXTURES

Pneumatic Fixtures

Model No.	Load Capacity			Pneumatic Actuation	Jaw Face	Jaw Opening (Max)		Clamping Surface		Weight (each)		Clevis Type	Supply
	N	KGF	LBF			in	mm	in	mm	lbs	kgs		
PNEUM-56GKA-1	2,500	250	550	Single	No Jaws	Jaw Dependent	Jaw Dependent	Jaw Dependent	Jaw Dependent	1.5	15.9	2	
PNEUM-56G2KA-1	2,500	250	550	Dual	No Jaws	Jaw Dependent	Jaw Dependent	Jaw Dependent	Jaw Dependent	1.9	15.9	2	
PNEUM-56GHKA-1	2,500	250	550	Single	No Jaws	Jaw Dependent	Jaw Dependent	Jaw Dependent	Jaw Dependent	1.9	15.9	2	
PNEUM-56GH2KA-1	2,500	250	550	Dual	No Jaws	Jaw Dependent	Jaw Dependent	Jaw Dependent	Jaw Dependent	2.3	15.9	2	

DIMENSIONS

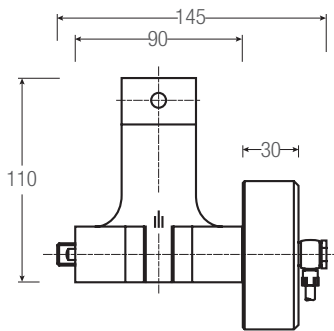

PNEUM-56GKA-1

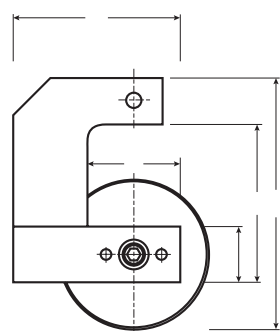

PNEUM-56G2KA-1

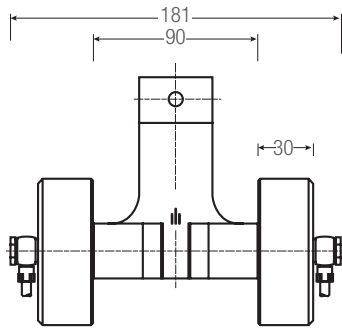

PNEUM-56GHKA-1

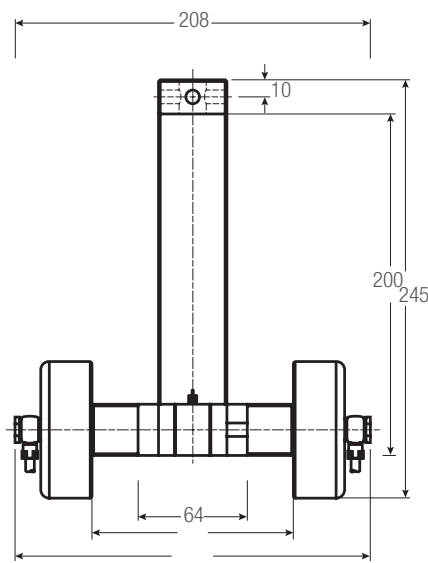
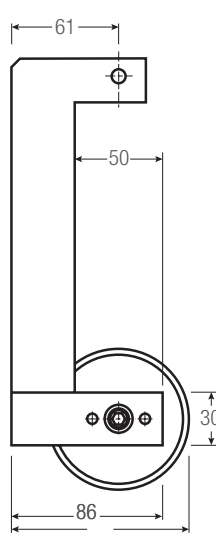

PNEUM-56GH2KA-1

PNEUMATIC FIXTURES

56G JAW SETS

STEEL, HARDENED

- Supplied four (4) jaws per set
- Operating Temperatures 32° to 266°F (0° to 130°C)

Jaw Sets						
Model No.	Jaw Face	Jaw Opening (Max)		Clamping Surface		
		in	mm	in	mm	
JAW56G-B30	Smooth	0.6	15	1.18 x 1.97	30 x 50	
JAW56G-BR30	Rubber	0.5	13	1.18 x 1.97	30 x 50	
JAW56G-PY30	Serrated	0.6	15	1.18 x 1.97	30 x 50	
JAW56G-V2	V-Notch	0.08-0.6 ϕ	2-15 ϕ	1.18 x 1.97	30 x 50	
JAW56G-V3	V-Notch	0.12-0.4 ϕ	3-11 ϕ	1.18 x 1.97	30 x 50	
JAW56G-WV30	Wave	0.6	15	1.18 x 1.97	30 x 50	
JAW56G-D30	Diamond	0.6	15	1.18 x 1.97	30 x 50	

OPTIONAL CARRIER AND CARRIER SETS

STEEL, HARDENED

- Supplied four (4) jaws per set
- Operating Temperatures 32° to 266°F (0° to 130°C)
- Quick Change jaw sets require both CARRIER56K and CAR56K

Carrier Sets									
Model No.	Material	Face	Jaw Dimensions (h x w)		Opening Width		Opening Width		Supply each
			in	mm	in (h x w)	mm (GA-1)	in (h x w)	mm (GHA-1)	
CARRIER-56G	Steel	-	-	-	-	-	-	-	4
CAR56G-B50	Steel	Smooth	1.18 x 1.97	30 x 50	0 - 0.2	0 - 5	0 - 1.3	0 - 34	4
CAR56G-BR50	Steel	Rubber	1.18 x 1.97	30 x 50	0 - 0.1	0 - 3	0 - 1.2	0 - 32	4
CAR56G-D50	Steel	Diamond	1.18 x 1.97	30 x 50	0 - 0.2	0 - 5	0 - 1.3	0 - 34	4
CAR56G-PY50	Steel	Serrated	1.18 x 1.97	30 x 50	0 - 0.2	0 - 5	0 - 1.3	0 - 34	4

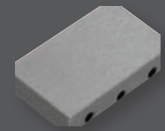

SMOOTH JAW

- Suitable for own further treatments
- Steel-blanks without coating

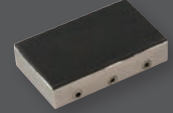

RUBBER-COATED JAW

- 1mm rubber coating (NBR)
- Nickel-plated

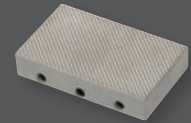

SERRATED JAW

- Pyramids 1.2 x 45°
- Hardened steel 58HRC
- Nickel-plated

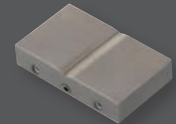

V-NOTCH JAW

- For all kinds of round samples
- Tooth pitch 1.2 mm
- Hardened steel
- Nickel-plated

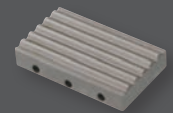

WAVE JAW

- For flexible materials
- Wave 5mm
- Hardened steel 58HRC
- Nickel-plated

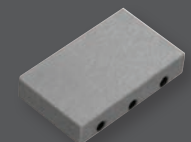

DIAMOND-COATED JAW

- Clamping surface coated with synthetic diamonds
- D91 (170/200 mesh)
- Nickel-plated

PNEUMATIC FIXTURES

240KP

ALUMINUM, ANODIZED

- For general-purpose tensile testing applications
- Self-aligning, self-tightening
- Order required jaw set separately
- Operating Temperatures 32° to 158°F (0° to 70°C)

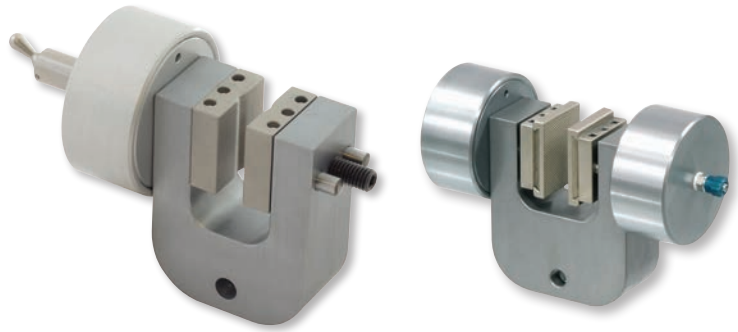

Pneumatic Fixtures

Model No.	Load Capacity			Pneumatic Actuation	Jaw Face	Jaw Opening (Max)		Clamping Surface		Weight (each)		Clevis Type	
	N	KGF	LBF			in	mm	in	mm	lbs	kgs	mm	Supply
PNEUM-240KA-1	2.5kN	250	562	Single	No Jaws	~.4	~10	Jaw Dependent	0.9	0.4	15.9	2	
PNEUM-2402KA-1	2.5kN	250	562	Dual	No Jaws	~.4	~10	Jaw Dependent	1.3	0.6	15.9	2	
PNEUM-240KA-20-1	1kN	100	225	Single	No Jaws	~.75	~20	Jaw Dependent	1.1	0.5	15.9	2	
PNEUM-2402KA-20-1	1kN	100	225	Dual	No Jaws	~.75	~20	Jaw Dependent	1.54	0.7	15.9	2	
PNEUM-240KA-30-1	1kN	100	225	Single	No Jaws	~1.2	~30	Jaw Dependent	1.2	0.54	15.9	2	
PNEUM-2402KA-30-1	1kN	100	225	Dual	No Jaws	~1.2	~30	Jaw Dependent	1.6	0.74	15.9	2	
PNEUM-240KA-50-1	1kN	100	225	Single	No Jaws	~2	~50	Jaw Dependent	1.8	0.8	15.9	2	
PNEUM-2402KA-50-1	1kN	100	225	Dual	No Jaws	~2	~50	Jaw Dependent	2.2	1.0	15.9	2	

DIMENSIONS

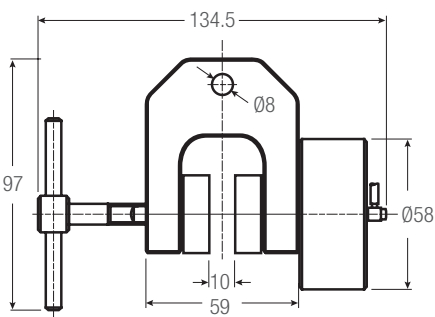

PNEUM-240KA-1

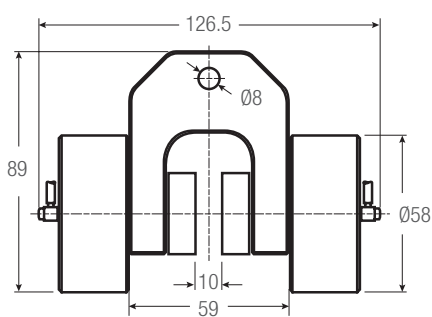
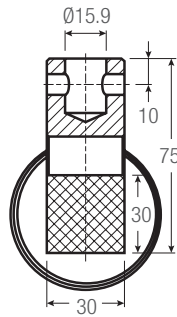

PNEUM-2402KA-1

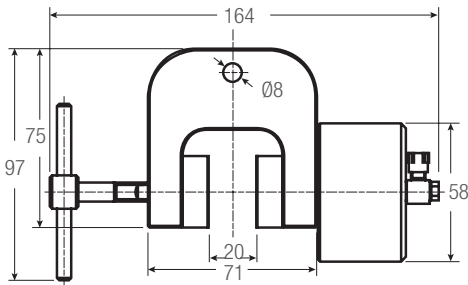
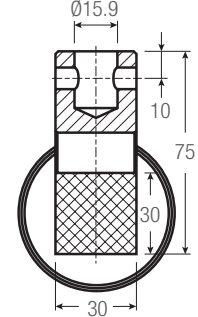

PNEUM-240KA-20-1

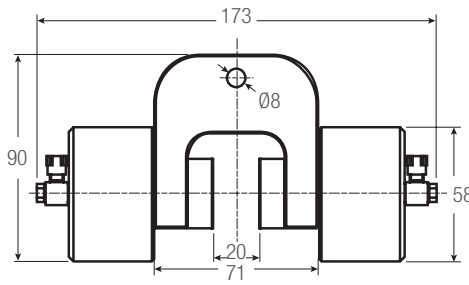
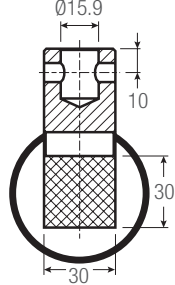

PNEUM-2402KA-20-1

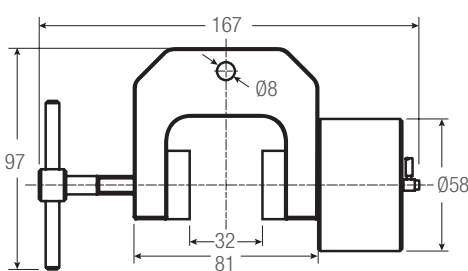
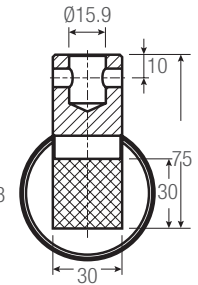

PNEUM-240KA-30-1

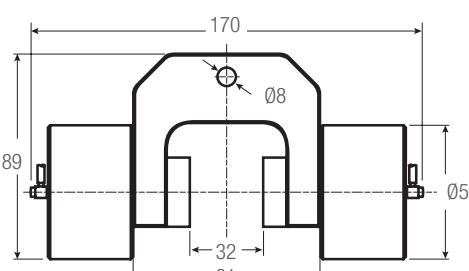
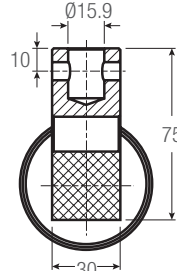

PNEUM-2402KA-30-1

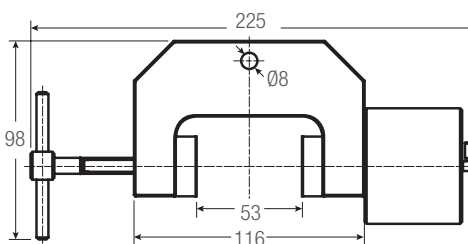
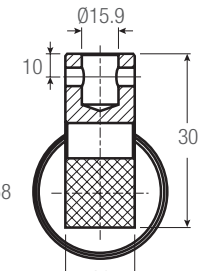

PNEUM-240KA-50-1

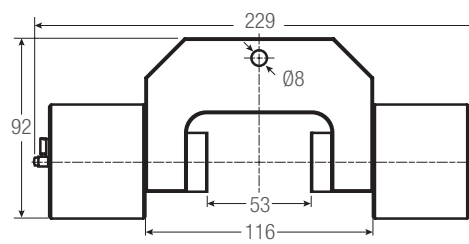
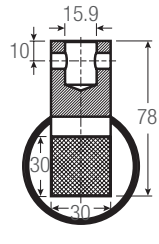

PNEUM-2402KA-50-1

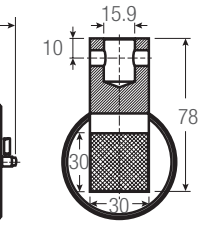

PNEUMATIC FIXTURES

240K JAW SETS

STEEL, HARDENED

- Supplied four (4) jaws per set
- Operating Temperatures 32° to 266°F (0° to 180°C)

Jaw Sets	Jaw Face	Jaw Opening (Max)								Clamping Surface	
		WISE-240KA-1		WISE-240KA-20-1		WISE-240KA-30-1		WISE-240KA-50-1			
Model No.		in	mm	in	mm	in	mm	in	mm	in	mm
JAW240K-B25	Smooth	0.4	10	0.8	20	1.2	30	2.0	52	1.18 x 1.18	30 x 30
JAW240K-BR25	Rubber	0.3	8	0.7	18	1.1	28	2.0	50	1.18 x 1.18	30 x 30
JAW240K-PY25	Serrated	0.4	10	0.8	20	1.2	30	2.0	52	1.18 x 1.18	30 x 30
JAW240K-V2	V-Notch	0.08-0.35 \emptyset	2-9 \emptyset	0.08-0.8 \emptyset	2-20 \emptyset	0.08-1.2 \emptyset	2-30 \emptyset	0.08-2.05 \emptyset	2-52 \emptyset	1.18 x 1.18	30 x 30
JAW240K-V9	V-Notch	0.1-0.35 \emptyset	3-9 \emptyset	0.1-0.8 \emptyset	3-20 \emptyset	0.1-1.2 \emptyset	3-30 \emptyset	0.1-2.05 \emptyset	3-52 \emptyset	1.18 x 1.18	30 x 30
JAW240K-WV30	Wave	0.4	10	0.8	20	1.2	30	2.0	52	1.18 x 1.18	30 x 30
JAW240K-D30	Diamond	0.4	10	0.8	20	1.2	30	2.0	52	1.18 x 1.18	30 x 30
JAW240K-B50	Smooth	0.8	20	0.8	20	1.2	30	2.0	52	1.18 x 2	30 x 50
JAW240K-BR50	Rubber	0.7	18	0.7	18	1.1	28	2.0	50	1.18 x 2	30 x 50
JAW240K-PY50	Serrated	0.8	20	0.8	20	1.2	30	2.0	52	1.18 x 2	30 x 50
JAW240K-WV50	Wave	0.8	20	0.8	20	1.2	30	2.0	52	1.18 x 2	30 x 50
JAW240K-D50	Diamond	0.8	20	0.8	20	1.2	30	2.0	52	1.18 x 2	30 x 50
JAW240K-B80	Smooth	1.2	30	0.8	20	1.2	30	2.0	52	1.18 x 3.2	30 x 80
JAW240K-BR80	Rubber	1.1	28	0.7	18	1.1	28	2.0	50	1.18 x 3.2	30 x 80
JAW240K-PY80	Serrated	1.2	30	0.8	20	1.2	30	2.0	52	1.18 x 3.2	30 x 80
JAW240K-WV80	Wave	1.2	30	0.8	20	1.2	30	2.0	52	1.18 x 3.2	30 x 80
JAW240K-D80	Diamond	1.2	30	0.8	20	1.2	30	2.0	52	1.18 x 3.2	30 x 80
JAW240K-B100	Smooth	2	50	0.8	20	1.2	30	2.0	52	1.18 x 3.9	30 x 100
JAW240K-BR100	Rubber	1.9	48	0.7	18	1.1	28	2.0	50	1.18 x 3.9	30 x 100
JAW240K-PY100	Serrated	2	50	0.8	20	1.2	30	2.0	52	1.18 x 3.9	30 x 100
JAW240K-WV100	Wave	2	50	0.8	20	1.2	30	2.0	52	1.18 x 3.9	30 x 100
JAW240K-D100	Diamond	2	50	0.8	20	1.2	30	2.0	52	1.18 x 3.9	30 x 100

OPTIONAL CARRIER AND CARRIER SETS

STEEL, HARDENED

- Supplied four (4) jaws per set
- Operating Temperatures 32° to 266°F (0° to 130°C)
- Quick Change jsaw sets require both CARRIER56K and CAR56K

Carrier Sets													
Model No.	Material	Face	Jaw Dimensions (h x w)		Opening Width (KA-1)		Opening Width (KA-20-1)		Opening Width (KA-30-1)		Opening Width (KA-50-1)		Supply each
			in	mm	in	mm	in	mm	in	mm	in	mm	
CARRIER-240K	Steel	-	-	-	-	-	-	-	-	-	-	-	4
CAR240K-B36	Steel	Smooth	1.2 x 1.2	30 x 30	0 - 0.3	0 - 8	0 - 0.7	0 - 18	0 - 1.1	0 - 28	0 - 1.9	0 - 48	4
CAR240K-BR36	Steel	Rubber	1.2 x 1.2	30 x 30	0 - 0.2	0 - 6	0 - 0.6	0 - 16	0 - 1	0 - 26	0 - 1.8	0 - 46	4
CAR240K-D36	Steel	Diamond	1.2 x 1.2	30 x 30	0 - 0.3	0 - 8	0 - 0.7	0 - 18	0 - 1.1	0 - 28	0 - 1.9	0 - 48	4
CAR240K-PY36	Steel	Serrated	1.2 x 1.2	30 x 30	0 - 0.3	0 - 8	0 - 0.7	0 - 18	0 - 1.1	0 - 28	0 - 1.9	0 - 48	4



SMOOTH JAW

- Suitable for own further treatments
- Steel-blanks without coating

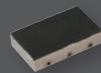

RUBBER-COATED JAW

- 1mm rubber coating (NBR)
- Nickel-plated



SERRATED JAW

- Pyramids 1.2 x 45°
- Hardened steel 58HRC
- Nickel-plated



V-NOTCH JAW

- For all kinds of round samples
- Tooth pitch 1.2 mm
- Hardened steel
- Nickel-plated



WAVE JAW

- For flexible materials
- Wave 5mm
- Hardened steel 58HRC
- Nickel-plated



DIAMOND-COATED JAW

- Clamping surface coated with synthetic diamonds
- D91 (170/200 mesh)
- Nickel-plated

PNEUMATIC FIXTURES

240GP

ALUMINUM, ANODIZED

- For general-purpose tensile testing applications
- Self-aligning, self-tightening
- Order required jaw set separately
- Operating Temperatures 32° to 158°F (0° to 70°C)

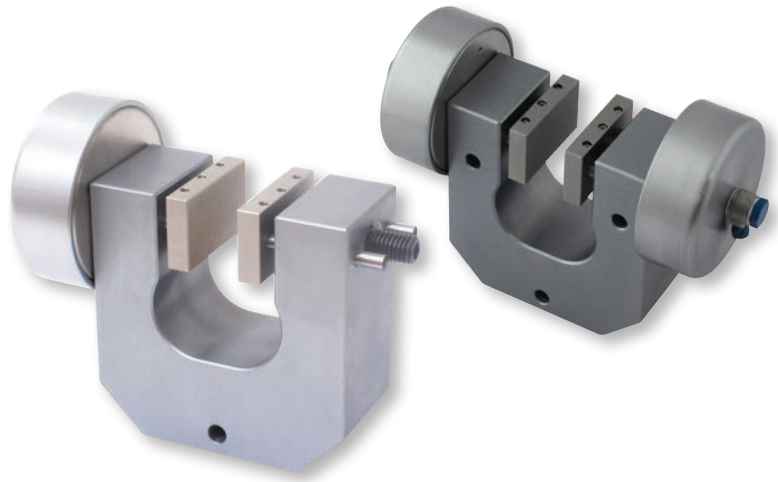

Pneumatic Fixtures

Model No.	Load Capacity			Pneumatic Actuation	Jaw Face	Jaw Opening (Max)		Clamping Surface		Weight (each)		Clevis Type	Supply
	N	KGF	LBF			in	mm	in	mm	lbs	kgs		
PNEUM-240G+KO	2,600	260	585	Single	No Jaws	Jaw Dependent		Jaw Dependent		3.3	1.5	15.9	2
PNEUM-240G+2KO	2,600	260	585	Dual	No Jaws	Jaw Dependent		Jaw Dependent		5.1	2.3	15.9	2

DIMENSIONS

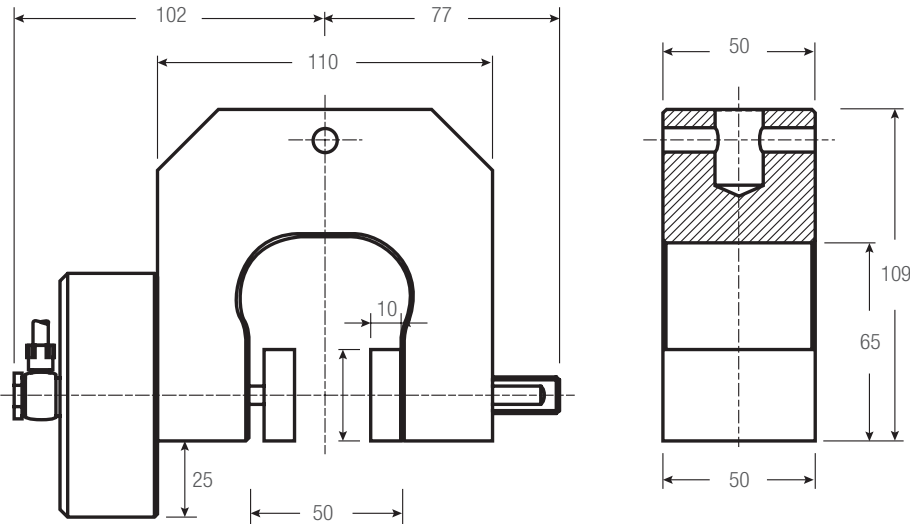

PNEUM-240G+KO

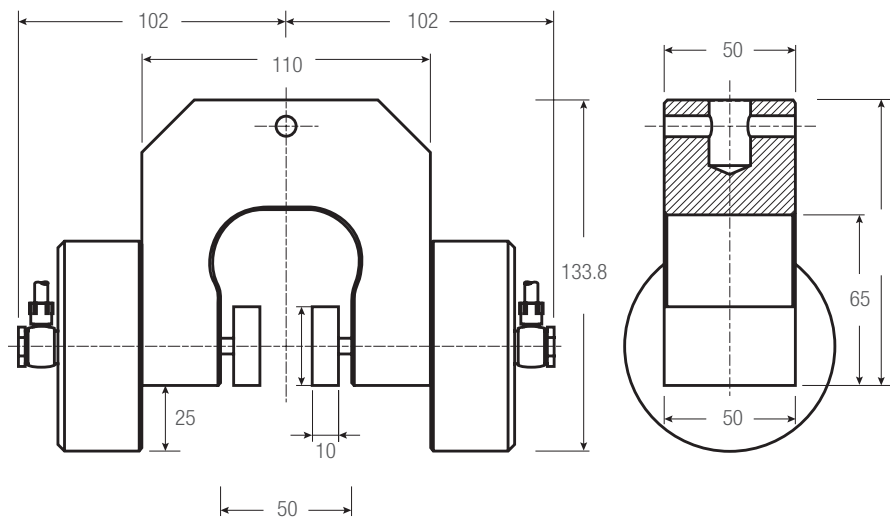

PNEUM-240G+2KO

PNEUMATIC FIXTURES

240G JAW SETS

STEEL, HARDENED

- Supplied four (4) jaws per set
- Operating Temperatures 32° to 266°F (0° to 180°C)

Jaw Sets					
Model No.	Jaw Face	Jaw Opening (Max) PNEUM-240G		Clamping Surface	
		in	mm	in	mm
JAW240G-B50	Smooth	0.7	18	1.18 x 2	30 x 50
JAW240G-BR50	Rubber	0.6	16	1.18 x 2	30 x 50
JAW240G-PY50	Serrated	0.7	18	1.18 x 2	30 x 50
JAW240G-V2	V-Notch	0.08-0.7 ϕ	2-18 ϕ	1.18 x 2	30 x 50
JAW240G-V5	V-Notch	0.2-0.7 ϕ	5-18 ϕ	1.18 x 2	30 x 50
JAW240G-WV50	Wave	0.7	18	1.18 x 2	30 x 50
JAW240G-D50	Diamond	0.7	18	1.18 x 2	30 x 50
JAW240G-B80	Smooth	0.7	18	1.18 x 3.2	30 x 80
JAW240G-BR80	Rubber	0.0	1	1.18 x 3.2	30 x 80
JAW240G-PY80	Serrated	0.7	18	1.18 x 3.2	30 x 80
JAW240G-WV80	Wave	0.7	18	1.18 x 3.2	30 x 80
JAW240G-D80	Diamond	0.7	18	1.18 x 3.2	30 x 80
JAW240G-B100	Smooth	0.8	20	1.18 x 3.9	30 x 100
JAW240G-BR100	Rubber	0.7	18	1.18 x 3.9	30 x 100
JAW240G-PY100	Serrated	0.8	20	1.18 x 3.9	30 x 100
JAW240G-WV100	Wave	0.8	20	1.18 x 3.9	30 x 100
JAW240G-D100	Diamond	0.8	20	1.18 x 3.9	30 x 100

OPTIONAL CARRIER AND CARRIER SETS

STEEL, HARDENED

- Supplied four (4) jaws per set
- Operating Temperatures 32° to 266°F (0° to 130°C)
- Quick Change jsaw sets require both CARRIER240K and CAR240K

Carrier Sets							
Model No.	Material	Face	Jaw Dimensions (h x w)		Opening Width (240G)		Supply each
			in	mm	in	mm	
CARRIER-240G	Steel	-	-	-	-	-	4
CAR240G-B50	Steel	Smooth	1.2 x 2.0	30 x 50	0 - 0.8	0 - 20	4
CAR240G-BR50	Steel	Rubber	1.2 x 2.0	30 x 50	0 - 0.7	0 - 18	4
CAR240G-D50	Steel	Diamond	1.2 x 2.0	30 x 50	0 - 0.8	0 - 20	4
CAR240G-PY50	Steel	Serrated	1.2 x 2.0	30 x 50	0 - 0.8	0 - 20	4



SMOOTH JAW

- Suitable for own further treatments
- Steel-blanks without coating

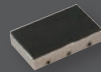

RUBBER-COATED JAW

- 1mm rubber coating (NBR)
- Nickel-plated

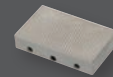

SERRATED JAW

- Pyramids 1.2 x 45°
- Hardened steel 58HRC
- Nickel-plated



V-NOTCH JAW

- For all kinds of round samples
- Tooth pitch 1.2 mm
- Hardened steel
- Nickel-plated



WAVE JAW

- For flexible materials
- Wave 5mm
- Hardened steel 58HRC
- Nickel-plated



DIAMOND-COATED JAW

- Clamping surface coated with synthetic diamonds
- D91 (170/200 mesh)
- Nickel-plated

PNEUMATIC FIXTURES

83A

ALUMINUM, ANODIZED

- For general-purpose tensile testing applications
- Order required jaw set separately
- 1/8" pneumatic thread connection
- Operating Temperatures 32° to 158°F (0° to 70°C)

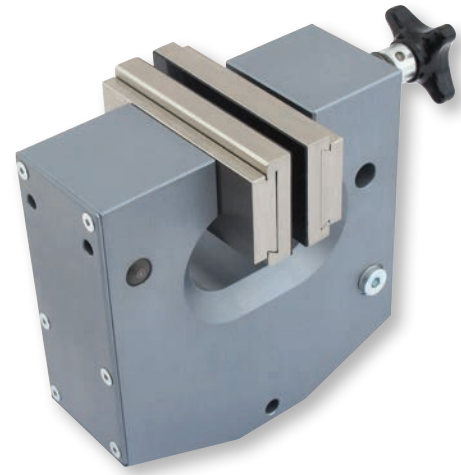

Pneumatic Fixtures												
Model No.	Load Capacity			Jaw Face	Jaw Opening (Max)		Clamping Surface		Weight (each)		Clevis Type mm	Supply
	N	KGF	LBF		in	mm	in	mm	lbs	kgs		
PNEUM-83A-1	7,000	700	1,570	No Jaws	Jaw Dependent	Jaw Dependent	Jaw Dependent	Jaw Dependent	7.1	3.2	15.9	2

DIMENSIONS

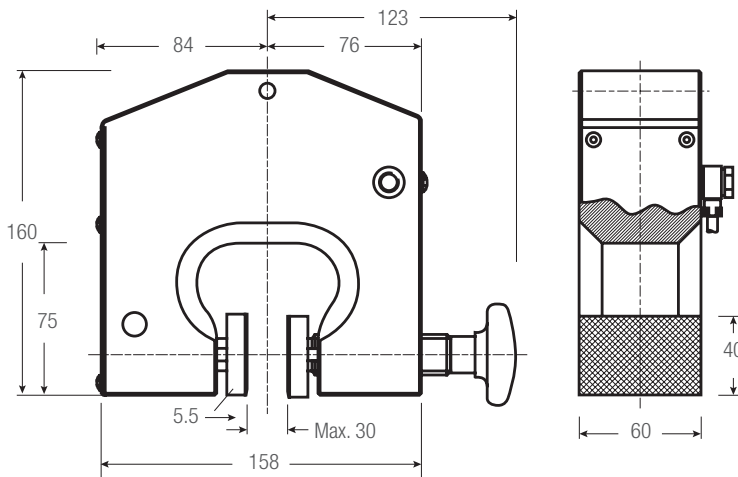

83P JAW SETS

STEEL, HARDENED

- Supplied four (4) jaws per set
- Operating Temperatures 32° to 158°F (0° to 70°C)

Jaw Sets					
Model No.	Jaw Face	Jaw Opening (Max)		Clamping Surface	
		in	mm	in	mm
JAW83-B60	Smooth	0.4	10	1.6 x 2.4	40 x 60
JAW83-BR60	Rubber	0.3	8	1.6 x 2.4	40 x 60
JAW83-PY60	Serrated	0.4	10	1.6 x 2.4	40 x 60
JAW83-V4	V-Notch	0.16-0.47 ϕ	4-12 ϕ	1.6 x 2.4	40 x 60
JAW83-V6	V-Notch	0.2-1.18 ϕ	6-30 ϕ	1.6 x 2.4	40 x 60
JAW83-WV60	Wave	0.4	10	1.6 x 2.4	40 x 60
JAW83-D60	Diamond	0.4	10	1.6 x 2.4	40 x 60
JAW83-B100	Smooth	0.4	10	1.6 x 3.9	40 x 100
JAW83-BR100	Rubber	0.3	8	1.6 x 3.9	40 x 100
JAW83-PY100	Serrated	0.4	10	1.6 x 3.9	40 x 100
JAW83-WV100	Wave	0.4	10	1.6 x 3.9	40 x 100
JAW83-D100	Diamond	0.4	10	1.6 x 3.9	40 x 100



SMOOTH JAW

- Suitable for own further treatments
- Steel-blanks without coating



RUBBER-COATED JAW

- 1mm rubber coating (NBR)
- Nickel-plated



SERRATED JAW

- Pyramids 1.2 x 45°
- Hardened steel 58HRC
- Nickel-plated

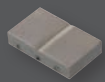

V-NOTCH JAW

- For all kinds of round samples
- Tooth pitch 1.2 mm
- Hardened steel
- Nickel-plated



WAVE JAW

- For flexible materials
- Wave 5mm
- Hardened steel 58HRC
- Nickel-plated

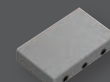

DIAMOND-COATED JAW

- Clamping surface coated with synthetic diamonds
- D91 (170/200 mesh)
- Nickel-plated

PNEUMATIC FIXTURES

108P

ALUMINUM, ANODIZED

- For general-purpose tensile testing applications
- Self-aligning, self-tightening
- Order required jaw set separately
- Operating Temperatures 32° to 158°F (0° to 70°C)

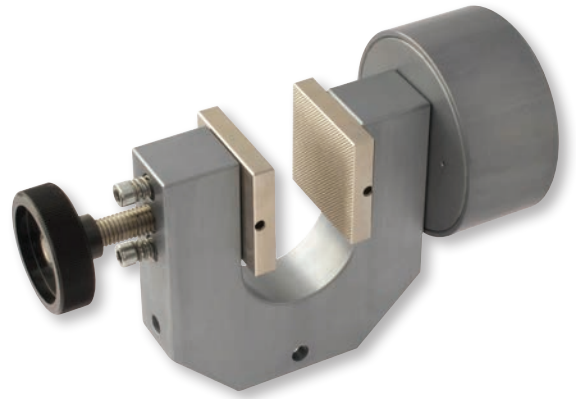

Pneumatic Fixtures												
Model No.	Load Capacity			Jaw Face	Jaw Opening (Max)		Clamping Surface		Weight (each)		Clevis Type	Supply
	N	KGf	LBF		in	mm	in	mm	lbs	kgs		
PNEUM-108A-1	3,500	350	785	No Jaws	Jaw Dependent		Jaw Dependent		2.9	1.3	15.9	2

DIMENSIONS

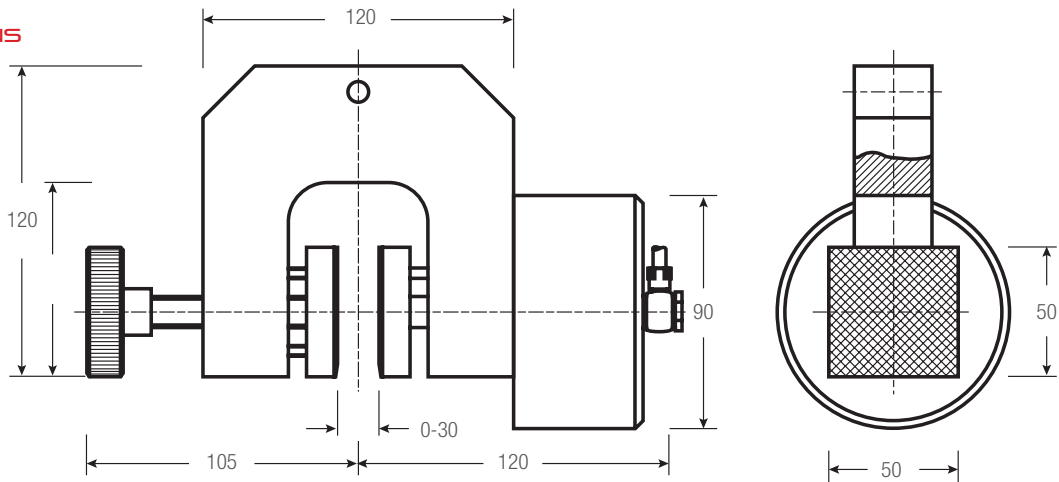

108P JAW SETS

STEEL, HARDENED

- Supplied four (4) jaws per set
- Operating Temperatures 32° to 158°F (0° to 70°C)

Jaw Sets					
Model No.	Jaw Face	Jaw Opening (Max)		Clamping Surface	
		in	mm	in	mm
JAW108-B60	Smooth	1.34	34	1.97 x 1.97	50 x 50
JAW108-BR60	Rubber	1.26	32	1.97 x 1.97	50 x 50
JAW108-PY60	Serrated	1.34	34	1.97 x 1.97	50 x 50
JAW108-V4	V-Notch	0.16-1.18 \emptyset	4-30 \emptyset	1.97 x 1.97	50 x 50
JAW108-WV60	Wave	1.34	34	1.97 x 1.97	50 x 50
JAW108-D60	Diamond	1.34	34	1.97 x 1.97	50 x 50
JAW108-B100	Smooth	1.34	34	1.97 x 3.9	50 x 100
JAW108-BR100	Rubber	1.26	32	1.97 x 3.9	50 x 100
JAW108-PY100	Serrated	1.34	34	1.97 x 3.9	50 x 100
JAW108-WV100	Wave	1.34	34	1.97 x 3.9	50 x 100
JAW108-D100	Diamond	1.34	34	1.97 x 3.9	50 x 100

SMOOTH JAW

- Suitable for own further treatments
- Steel-blanks without coating

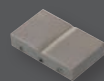

RUBBER-COATED JAW

- 1mm rubber coating (NBR)
- Nickel-plated

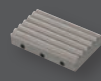

SERRATED JAW

- Pyramids 1.2 x 45°
- Hardened steel 58HRC
- Nickel-plated



V-NOTCH JAW

- For all kinds of round samples
- Tooth pitch 1.2 mm
- Hardened steel
- Nickel-plated

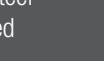

WAVE JAW

- For flexible materials
- Wave 5mm
- Hardened steel 58HRC
- Nickel-plated



DIAMOND-COATED JAW

- Clamping surface coated with synthetic diamonds
- D91 (170/200 mesh)
- Nickel-plated

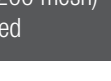

PNEUMATIC FIXTURES

126P

ALUMINUM, ANODIZED

- For general-purpose tensile testing applications
- Self-aligning, self-tightening
- Order required jaw set separately
- 1/8" pneumatic thread connection
- Operating Temperatures 32° to 158°F (0° to 70°C)



PNEUMATIC FIXTURES

Pneumatic Fixtures

Model No.	Load Capacity			Jaw Face	Jaw Opening (Max)		Clamping Surface		Weight (each)		Clevis Type	Supply
	N	KGf	LBF		in	mm	in	mm	lbs	kgs		
PNEUM-126A-1	30K	3,000	6,700	No Jaws	Jaw Dependent		Jaw Dependent		22	10	15.9	2

DIMENSIONS

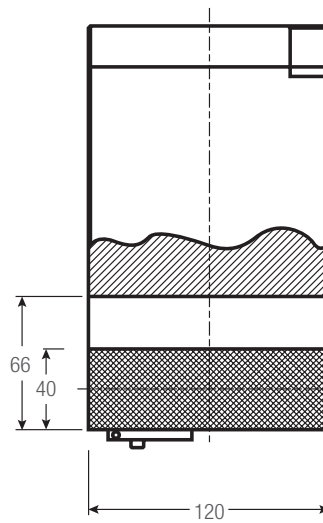
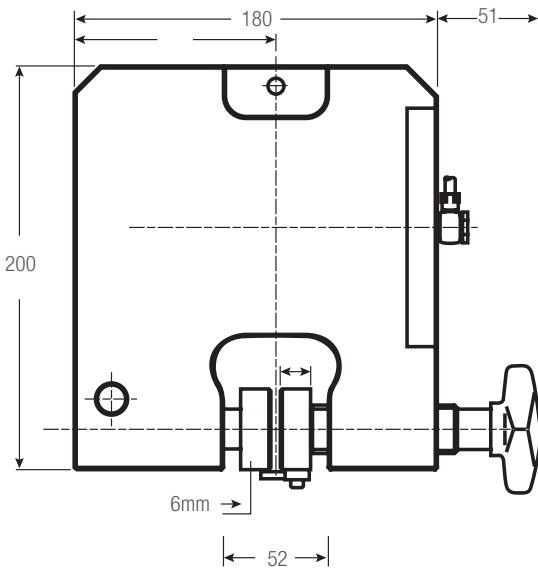

126P JAW SETS

STEEL, HARDENED

- Supplied four (4) jaws per set
- Operating Temperatures 32° to 158°F (0° to 70°C)

Jaw Sets

Model No.	Jaw Face	Jaw Opening (Max)		Clamping Surface	
		in	mm	in	mm
JAW126-B120	Smooth	0.5	12	1.6 x 4.7	40 x 120
JAW126-BR120	Rubber	0.4	10	1.6 x 4.7	40 x 120
JAW126-PY120	Serrated	0.5	12	1.6 x 4.7	40 x 120
JAW126-V6	V-Notch	0.23-0.67 ϕ	6-17 ϕ	1.6 x 4.7	40 x 120
JAW126-WV120	Wave	0.5	12	1.6 x 4.7	40 x 120
JAW126-D120	Diamond	0.5	12	1.6 x 4.7	40 x 120

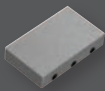

SMOOTH JAW

- Suitable for own further treatments
- Steel-blanks without coating



RUBBER-COATED JAW

- 1mm rubber coating (NBR)
- Nickel-plated

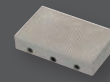

SERRATED JAW

- Pyramids 1.2 x 45°
- Hardened steel 58HRC
- Nickel-plated

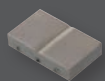

V-NOTCH JAW

- For all kinds of round samples
- Tooth pitch 1.2 mm
- Hardened steel
- Nickel-plated



WAVE JAW

- For flexible materials
- Wave 5mm
- Hardened steel 58HRC
- Nickel-plated



DIAMOND-COATED JAW

- Clamping surface coated with synthetic diamonds
- D91 (170/200 mesh)
- Nickel-plated

PNEUMATIC FIXTURES

149

ALUMINUM, ANODIZED

- For general-purpose tensile testing applications
- Self-aligning, self-tightening
- Order required jaw set separately
- 1/8" pneumatic thread connection
- Operating Temperatures 32° to 158°F (0° to 70°C)



Pneumatic Fixtures												
Model No.	Load Capacity			Jaw Face	Jaw Opening (Max)		Clamping Surface		Weight (each)		Clevis Type	Supply
	N	KGF	LBF		in	mm	in	mm	lbs	kgs		
PNEUM-149A-1	2,400	240	540	No Jaws	Jaw Dependent		Jaw Dependent		2.7	1.2	15.9	2

DIMENSIONS

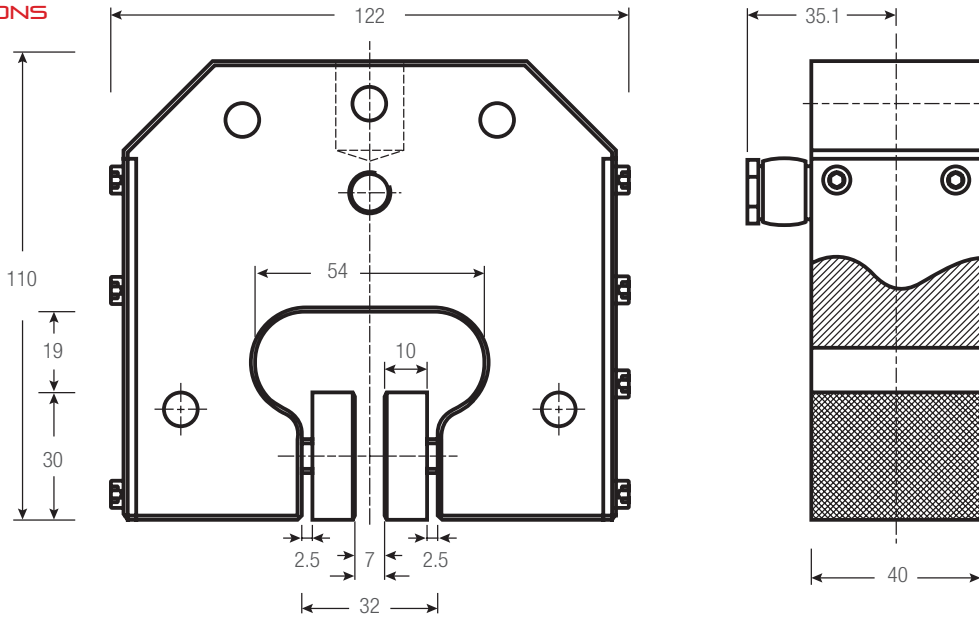

149 JAW SETS

STEEL, HARDENED

- Supplied four (4) jaws per set
- Operating Temperatures 32° to 158°F (0° to 70°C)

Jaw Sets					
Model No.	Jaw Face	Jaw Opening (Max)		Clamping Surface	
		in	mm	in	mm
JAW149-B50	Smooth	0.28	7	1.2 x 1.97	30 x 50
JAW149-BR50	Rubber	0.2	5	1.2 x 1.97	30 x 50
JAW149-PY50	Serrated	0.28	7	1.2 x 1.97	30 x 50
JAW149-V4	V-Notch	0.16-0.28 ϕ	4-7 ϕ	1.2 x 1.97	30 x 50
JAW149-WV50	Wave	0.28	7	1.2 x 1.97	30 x 50
JAW149-D50	Diamond	0.28	7	1.2 x 1.97	30 x 50

SMOOTH JAW

- Suitable for own further treatments
- Steel-blanks without coating

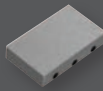

RUBBER-COATED JAW

- 1mm rubber coating (NBR)
- Nickel-plated

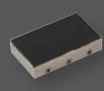

SERRATED JAW

- Pyramids 1.2 x 45°
- Hardened steel 58HRC
- Nickel-plated

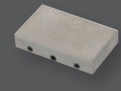

V-NOTCH JAW

- For all kinds of round samples
- Tooth pitch 1.2 mm
- Hardened steel
- Nickel-plated

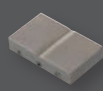

WAVE JAW

- For flexible materials
- Wave 5mm
- Hardened steel 58HRC
- Nickel-plated

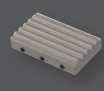

DIAMOND-COATED JAW

- Clamping surface coated with synthetic diamonds
- D91 (170/200 mesh)
- Nickel-plated

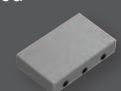

PNEUMATIC FIXTURES

232

ALUMINUM, ANODIZED

- For general-purpose tensile testing applications
- Self-aligning, self-tightening
- Order required jaw set separately
- Operating Temperatures 32° to 158°F (0° to 70°C)

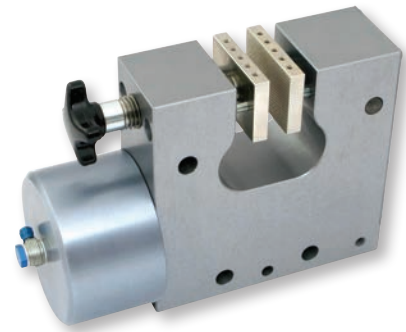

Pneumatic Fixtures												
Model No.	Load Capacity			Jaw Face	Jaw Opening (Max)		Clamping Surface		Weight (each)		Clevis Type mm	Supply
	N	KGf	LBF		in	mm	in	mm	lbs	kgs		
PNEUM-232A-1	16K	1,600	3,600	No Jaws	Jaw Dependent		Jaw Dependent		10.0	4.5	15.9	2

DIMENSIONS

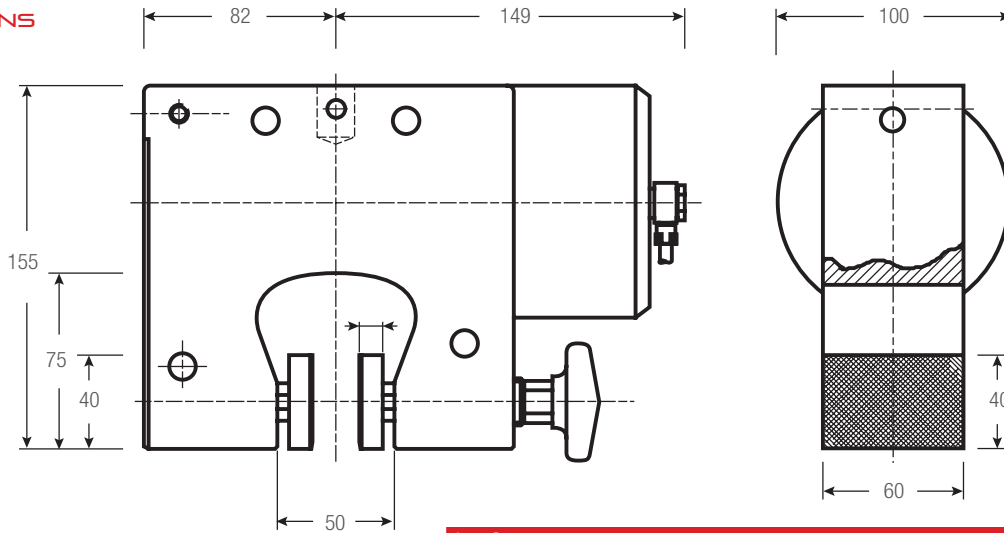

232 JAW SETS

STEEL, HARDENED

- Supplied four (4) jaws per set
- Operating Temperatures 32° to 158°F (0° to 70°C)

Jaw Sets					
Model No.	Jaw Face	Jaw Opening (Max)		Clamping Surface	
		in	mm	in	mm
JAW232-B60	Smooth	0.4	10	1.6 x 2.4	40 x 60
JAW232-BR60	Rubber	0.4	10	1.6 x 2.4	40 x 60
JAW232-PY60	Serrated	0.4	10	1.6 x 2.4	40 x 60
JAW232-V4	V-Notch	0.16-0.47ø	4-12ø	1.6 x 2.4	40 x 60
JAW232-V6	V-Notch	0.24-1.18ø	6-30ø	1.6 x 2.4	40 x 60
JAW232-WV60	Wave	0.4	10	1.6 x 2.4	40 x 60
JAW232-D60	Diamond	0.4	10	1.6 x 2.4	40 x 60
JAW232-B100	Smooth	0.4	10	1.6 x 3.9	40 x 100
JAW232-BR100	Rubber	0.4	10	1.6 x 3.9	40 x 100
JAW232-PY100	Serrated	0.4	10	1.6 x 3.9	40 x 100
JAW232-WV100	Wave	0.4	10	1.6 x 3.9	40 x 100
JAW232-D100	Diamond	0.4	10	1.6 x 3.9	40 x 100

SMOOTH JAW

- Suitable for own further treatments
- Steel-blanks without coating

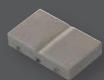

RUBBER-COATED JAW

- 1mm rubber coating (NBR)
- Nickel-plated

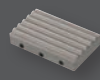

SERRATED JAW

- Pyramids 1.2 x 45°
- Hardened steel 58HRC
- Nickel-plated



V-NOTCH JAW

- For all kinds of round samples
- Tooth pitch 1.2 mm
- Hardened steel
- Nickel-plated



WAVE JAW

- For flexible materials
- Wave 5mm
- Hardened steel 58HRC
- Nickel-plated

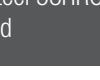

DIAMOND-COATED JAW

- Clamping surface coated with synthetic diamonds
- D91 (170/200 mesh)
- Nickel-plated

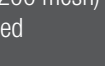

PNEUMATIC FIXTURES

13

ALUMINUM, ANODIZED

- For general-purpose tensile testing applications on fibers, wire, cord, fine wire, etc.
- Guide horn with centering groove
- Order required jaw set separately
- Operating Temperatures 32° to 176°F (0° to 80°C)

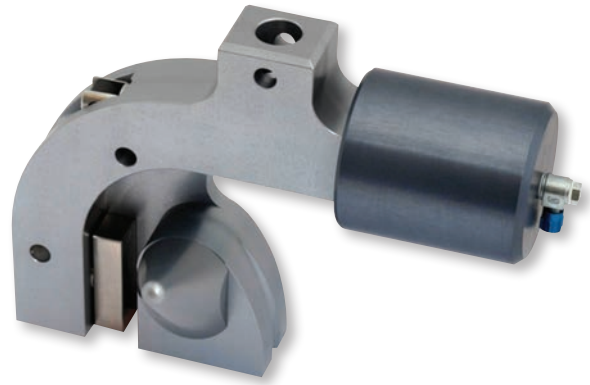

Pneumatic Fixtures											
Model No.	Load Capacity			Material	Face	Jaw Dimensions (h x w) mm	Opening Width mm	Weight (each)		Supply each	Clevis Size mm
	N	KGF	LBF					lbs	kgs		
PNEU-13G	5kN	500	1124	Aluminum	Smooth	15 x 44	0 - 3	2.9	1.3	2	15.9
PNEU-13G+BD	5kN	500	1124	Aluminum	Diamond	15 x 44	0 - 3	2.9	1.3	2	15.9
PNEU-13K	200	20	45	Aluminum	Smooth	6 x 20	0 - 1	0.23	0.1	2	15.9
PNEU-13K+BD	200	20	45	Aluminum	Diamond	6 x 20	0 - 1	0.23	0.1	2	15.9
PNEU-13M	2kN	200	450	Steel	Smooth	12 x 36	0 - 2	1.3	0.6	2	15.9
PNEU-13M-BD	2kN	200	450	Steel	Diamond	12 x 36	0 - 2	1.3	0.6	2	15.9

DIMENSIONS

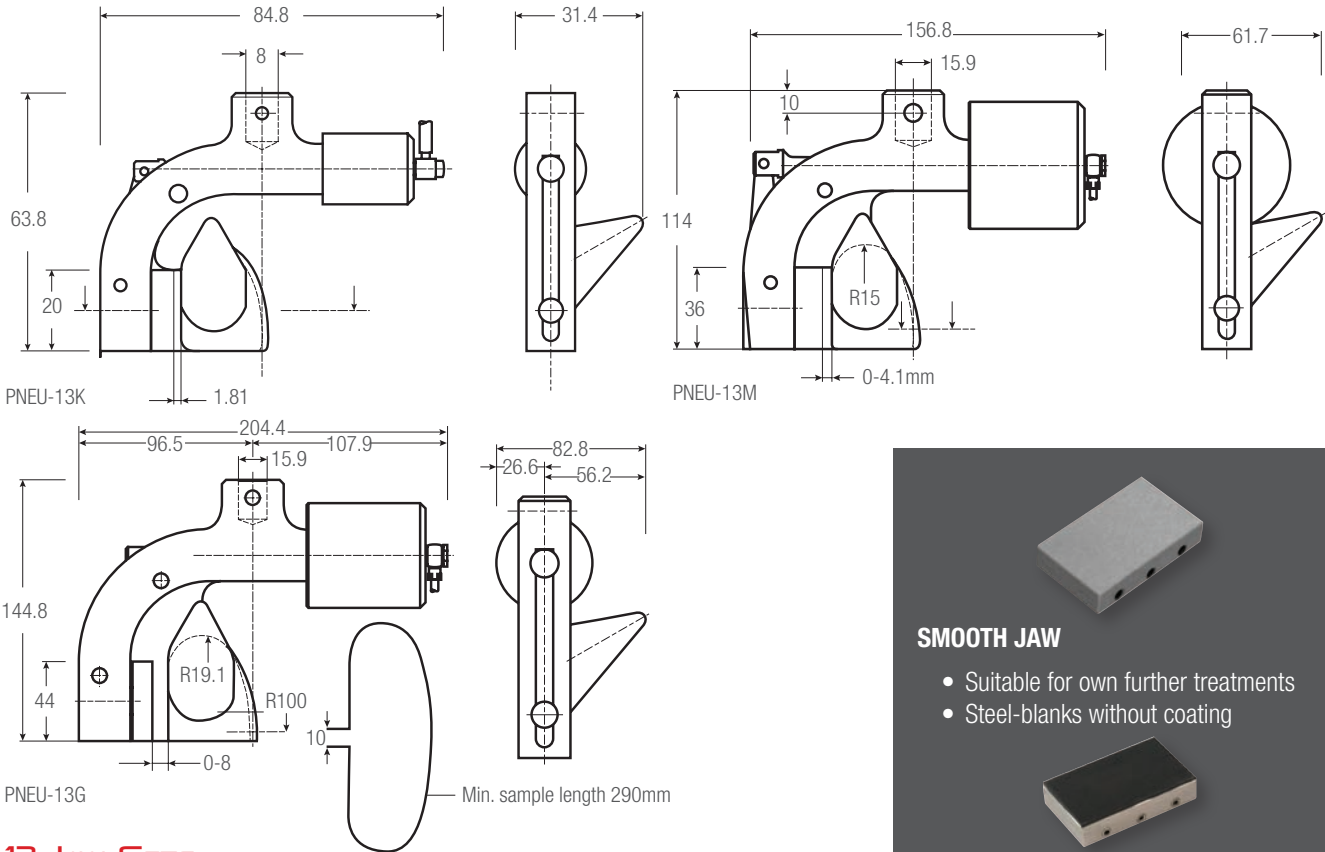

13 JAW SETS

STEEL, HARDENED

- Supplied two (2) jaws per set
- Operating Temperatures 32° to 176°F (0° to 80°C)

Jaw Sets						
Model No.		Material	Face	Jaw Dimensions (h x w) mm	Opening Width mm	Supply each
JAW13G-B	Jaw face sets PNEUM-13G	Steel	Smooth	15 x 44	0 - 3	4
JAW13G-BR		Steel	Rubber	15 x 44	0 - 3	4
JAW13G-D		Steel	Diamond	15 x 44	0 - 3	4
JAW13K-B	Jaw face sets PNEUM-13K	Steel	Smooth	6 x 20	0 - 1	4
JAW13K-BR		Steel	Rubber	6 x 20	0 - 1	4
JAW13K-D		Steel	Diamond	6 x 20	0 - 1	4
JAW13M-B	Jaw face sets PNEUM-13M	Steel	Smooth	12 x 36	0 - 2	4
JAW13M-BR		Steel	Rubber	12 x 36	0 - 2	4
JAW13M-D		Steel	Diamond	12 x 36	0 - 2	4

SMOOTH JAW

- Suitable for own further treatments
- Steel-blanks without coating

RUBBER-COATED JAW

- 1 mm rubber coating (NBR)
- Nickel-plated

SERRATED JAW

- Pyramids 1.2 x 45°
- Hardened steel 58HRC
- Nickel-plated

PNEUMATIC FIXTURES

76-5

ALUMINUM, ANODIZED

- For general-purpose tensile testing applications
- Use on small diameter wire, rope, filaments, thread, etc...
- Operating Temperatures 32° to 356°F (0° to 180°C)



Pneumatic Fixtures										
Model No.	Load Capacity			Material	Jaw Face	Jaw Opening (Max) mm	Jaw Dimensions mm (h x w)	Clevis Type mm	Supply	
	N	KGF	LBF							
PNEUM-76-5+K0	5kN	500	1,124	Aluminum	Serrated	0-2ø	20 x 20	15.9	2	

DIMENSIONS

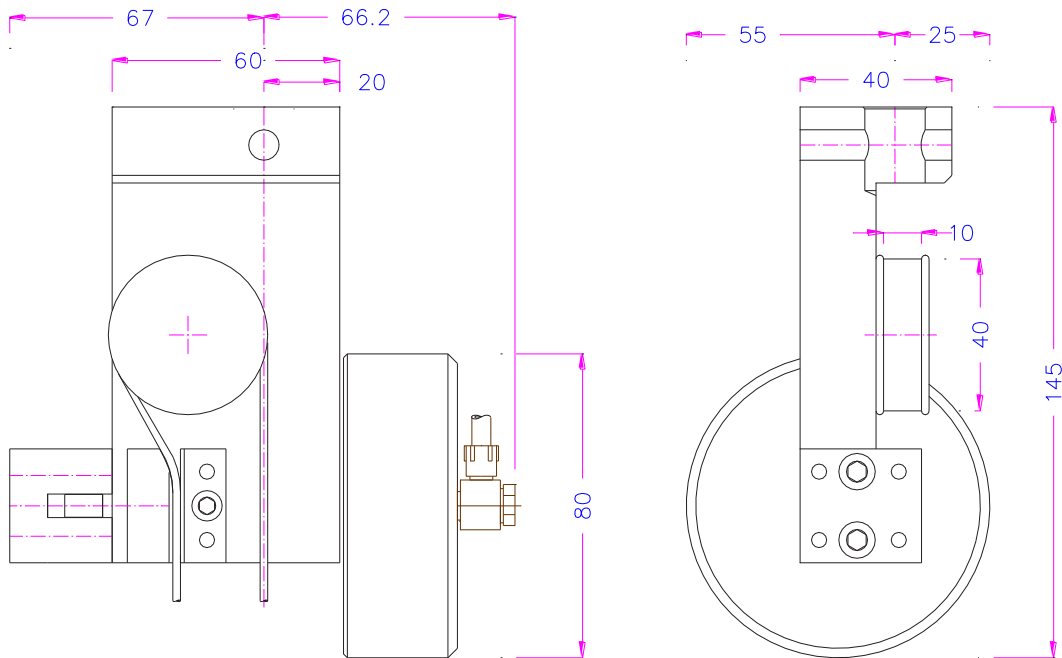

PNEUMATIC FIXTURES

501P

ALUMINUM, ANODIZED

- For general-purpose tensile testing applications
- Self-aligning, self-tightening
- Order required jaw set separately
- Operating Temperatures 32° to 158°F (0° to 70°C)



Pneumatic Fixtures

Model No.	Load Capacity			Jaw Face	Jaw Opening (Max)		Clamping Surface		Weight (each)		Clevis Type	Supply
	N	KGF	LBF		in	mm	in	mm	lbs	kgs		
PNEUM-501A-1	2,000	200	450	Serrated	0.24	6	0.2 x 0.2	5 x 5	1.8	0.8	15.9	1

DIMENSIONS

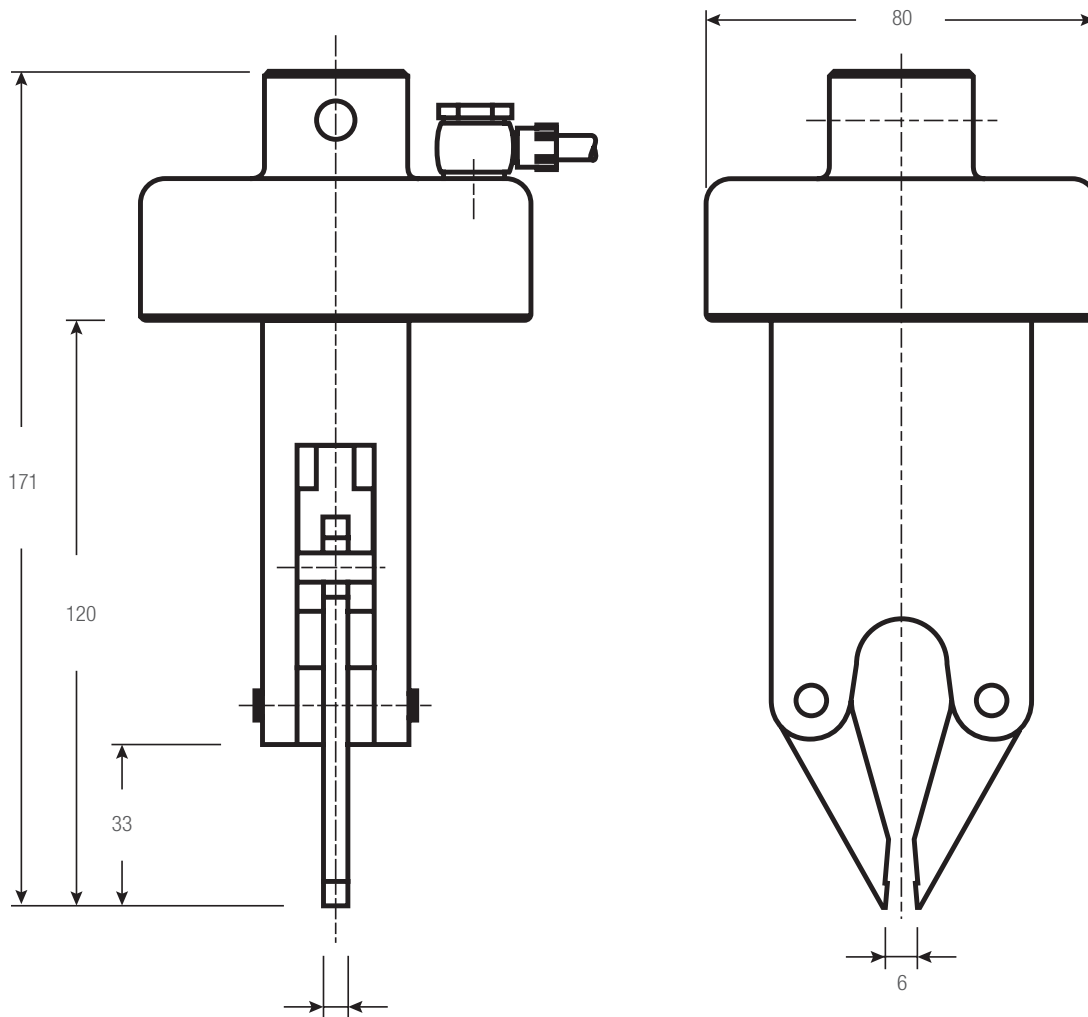

PNEUMATIC FIXTURES

ACCESSORIES

Pneumatic Accessories		
Model No.	Description	Supply
PNEUM-2051	Two (2ea) pneumatic foot switches, tubes and fittings, Non locking: The jaws of the grip open by pressing, the foot pedal and close after removing, the foot from the pedal. Includes 1 pair of pedals, tubes, and fittings	1
PNEUM-2052	Two (2ea) pneumatic foot switches, tubes and fittings, Locking function: The jaws open and remain, opened after removing the foot from the pedal. The jaws close by pressing one more time. Includes 1 pair of pedals, tubes, and fittings	1
PNEUM-205PR	Pressure regulator, To adjust air pressure 1-10 bar (14.5-145 psi), Optional for PNEUM-205-1 and PNEUM-205-2	1
PNEUM-2053	Pneumatic hand switches tubes and fittings, With locking function: Handle with 2 positions. The jaws close by pulling the handle and remain closed. The jaws open by pushing the handle back. Includes 1 unit, tubes, and fittings	1
PNEUM-205F	One (1ea) extra set fittings and tubes (1 Set is already included if you order PNEUM-205-1 or PNEUM-205-2 or PNEUM-205-3)	1

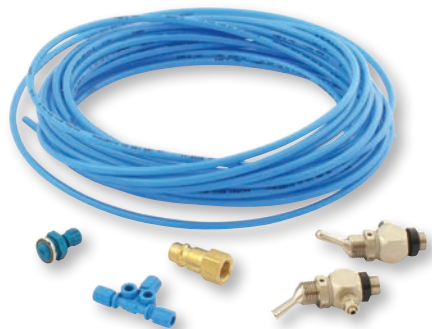

A Starrett spring test fixture is shown in a laboratory setting. The fixture is a tall, vertical, black metal structure with a central column. A horizontal bar across the middle of the column has the brand name "Starrett" printed in red. Below this bar, a coiled metal spring is mounted on a base. The base of the fixture is a black, rectangular block with a control panel on the left side featuring a red emergency stop button and a power switch on the right. The entire fixture is placed on a dark grey cabinet. The background shows a blurred laboratory environment with white walls and glass partitions.

Starrett

SPRING TEST FIXTURES

SPRING TEST FIXTURES

Starrett offers custom solutions for testing compression and extension springs. These test fixtures ensure correct axial alignment and promote accurate testing and measurements of spring constants, initial tension, free length and more.

OPERATION

Starrett can supply a variety of test fixtures for testing compression and extension springs. Generally, fixtures include hooks for extension springs and various forms of custom-made test fixtures for compression springs.



TESTING STANDARDS

There are a variety of testing methods for springs and washers. Contact your Starrett representative for more information about your specific testing method and the available test fixtures.

SPRING

STEEL, NICKEL FINISH

- For general-purpose spring testing applications
- Springs are positioned over the center rod to ensure proper alignment during compression
- Operating Temperatures 32° to 158°F (0° to 70°C)



Shown: Custom made testing fixtures for compression springs having different free lengths.

Spring Fixtures											
Model No.	Load Capacity			Inside Diameter (A)		Outside Diameter (B)		Weight (each)		Clevis Type	Supply
	N	KGF	LBF	in	mm	in	mm	lbs	kgs		
SPRING-[A]-[B]	100	10	22	A	A	B	B	TBD	TBD	15.9	1

Note: This fixtures are custom made and based on the spring inside diameter. Please consult your Starrett representative.

DIMENSIONS

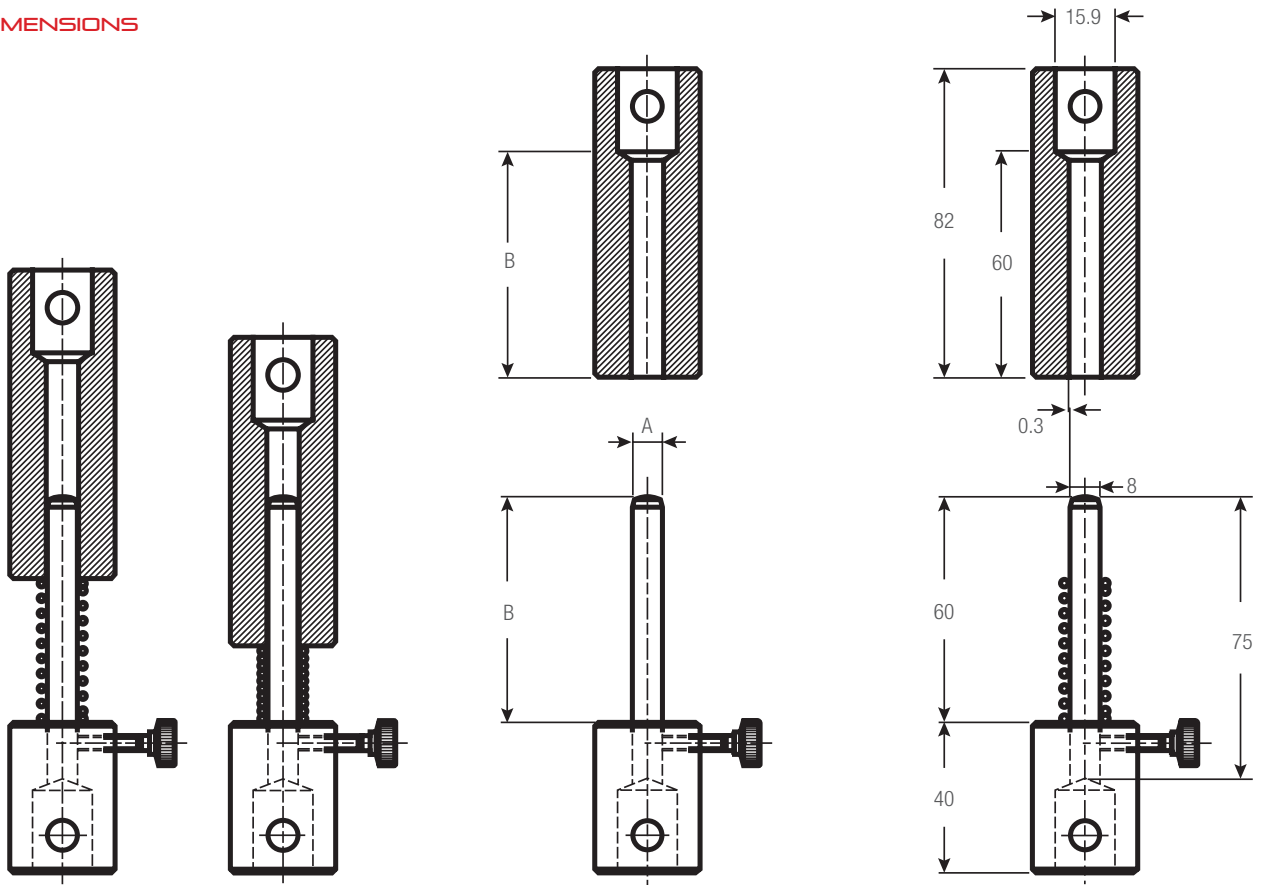



SYRINGE TEST FIXTURES

SYRINGE TEST FIXTURES

These specialized test fixtures are designed to test medical syringes. The fixture secures the syringe tube while the plunger is moved in both compressive and tensile directions. Test fixtures are available for 5mL, 10mL and 20mL size syringes.

Other sizes available upon request. The fixture design makes loading and unloading the syringe quick and easy.

SPRING

STEEL, NICKEL COATED

- For tensile and compression testing of medical syringes
- Includes three inserts: 5mL, 10mL and 20mL
- Operating Temperatures 32° to 158°F (0° to 70°C)



Syringe Fixtures													
Model No.	Load Capacity			Syringe Volume mL	Inside Cage Height		Cage Diameter (B)		Weight (each)		Clevis Type mm	Supply	
	N	KGf	LBF		in	mm	in	mm	lbs	kgs			
SYRINGE-727	250	25	56	5, 10, 20	7.8	200	3.78	96	6.5	3	15.9	1	

Note: Available on request, example fixture shown below.

DIMENSIONS

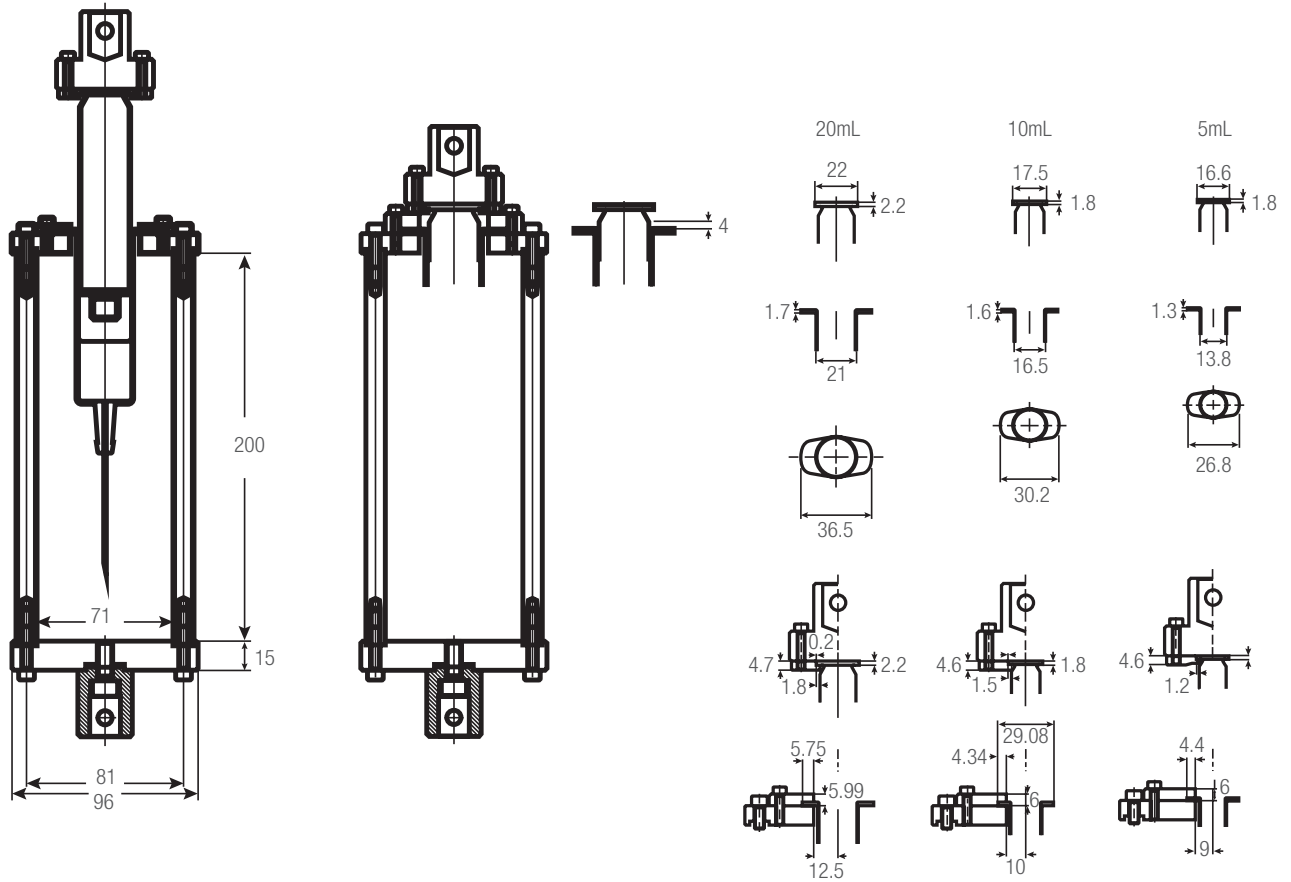



SCISSOR FIXTURES

SCISSOR FIXTURES

Scissor test fixtures secure the sample with a pinching force. The rate of clamping force changes depending on the jaw opening width. These are ideal for high-volume testing applications and are self-aligning and self-tightening.

OPERATION

Scissor test fixtures are self-tightening and self-aligning. The initial gripping force is supplied by spring tension. The clamping force to tensile force changes according to the jaw opening width. The larger the width, the more clamping force is applied.

TESTING STANDARDS

There are a variety of testing standards that may be used with scissor test fixtures. Contact your Starrett representative for more information about your specific testing method and the available test fixtures.



11

STEEL, STAINLESS

- For general-purpose tensile testing applications
- Spring tension tightening
- Jaw faces must be ordered separately
- Operating Temperatures -94° to 266°F (-70° to 130°C)

11 JAW SETS

STEEL, HARDENED

- Supplied two (2) jaws per set
- Operating Temperatures -94° to 266°F (-70° to 130°C)

Scissor Fixtures - SCISSOR-11SS-5-1											
Model No.	Load Capacity			Sample Width (Max)		Sample Thickness (Max)		Weight (each)		Clevis Type	Supply
	N	KGf	LBF	in	mm	in	mm	lbs	kgs		
SCISSOR-11SS-5-1	5,000	500	1,100	1.97	50	0.75	19	2.6	1.2	15.9	2

Jaw Sets - SCISSOR-11SS-5-1						
Model No.	Jaw Face	Jaw Opening (max)		Clamping Surface		Supply
		in	mm	in	mm	
JAW11-5-B50	Smooth	0 - 0.75	0 - 19	0 - 0.79	20 x 50	4
JAW11-5-PY50	Serrated	0 - 0.75	0 - 19	0 - 0.79	20 x 50	4

Scissor Fixtures - SCISSOR-11-20A-1											
Model No.	Load Capacity			Sample Width (Max)		Sample Thickness (Max)		Weight (each)		Clevis Type	Supply
	N	KGf	LBF	in	mm	in	mm	lbs	kgs		
SCISSOR-11-20A-1	20K	2,000	4,400	1.97	50	Jaw Dependent		4.4	2.0	15.9	2

Jaw Sets - SCISSOR-11-20A-1						
Model No.	Jaw Face	Jaw Opening (max)		Clamping Surface		Supply
		in	mm	in	mm	
JAW11-20-B50	Smooth	0 - 1	0 - 25	0.98 x 1.97	25 x 50	4
JAW11-20-B100	Smooth	0 - 1	0 - 25	0.98 x 3.94	25 x 100	4
JAW11-20-PY50	Serrated	0 - 1	0 - 25	0.98 x 1.97	25 x 50	4
JAW11-20-PY100	Serrated	0 - 1	0 - 25	0.98 x 3.94	25 x 100	4
JAW11-20-RD50	Serrated	0 - 0.79	0 - 20	0.98 Ø x 2.05	25 Ø x 52	4
JAW11-20-VEE4	Vee-Type	0.16 - 0.24	4 - 16 Ø	Clamp Height: 0.98	Clamp Height: 25	4
JAW11-20-WV50	Wave	0 - 1	0 - 25	0.98 x 1.97	25 x 50	4
JAW11-20-WV100	Wave	0 - 1	0 - 25	0.98 x 3.94	25 x 100	4

Scissor Fixtures - SCISSOR-11-50S-1											
Model No.	Load Capacity			Sample Width (Max)		Sample Thickness (Max)		Weight (each)		Clevis Type	Supply
	N	KGf	LBF	in	mm	in	mm	lbs	kgs		
SCISSOR-11-50S-1	50K	5,000	11,000	3.93	100	Jaw Dependent		20.1	9.1	15.9	2

Jaw Sets - SCISSOR-11-50S-1						
Model No.	Jaw Face	Jaw Opening (max)		Clamping Surface		Supply
		in	mm	in	mm	
JAW11-50-PY	Serrated	0 - 1.89	0 - 48	1.96 - 3.94	50 x 100	4
JAW11-50-V10	Vee-Type	0 - 1.89	0 - 48	0.39 - 1.89 Ø	10 - 48 Ø	4

SCISSOR FIXTURES

DIMENSIONS

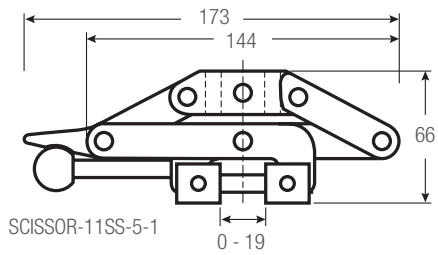
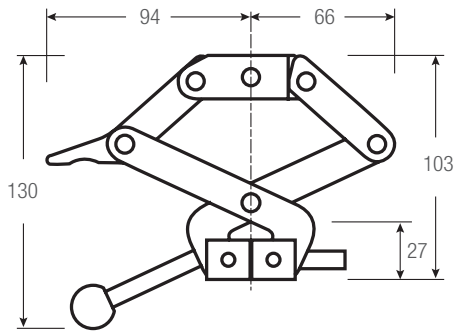

SCISSOR-11SS-5-1

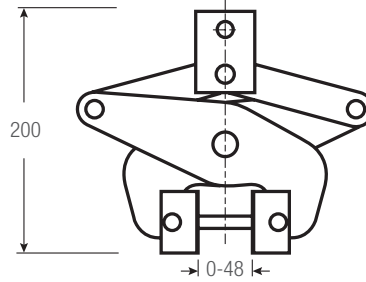
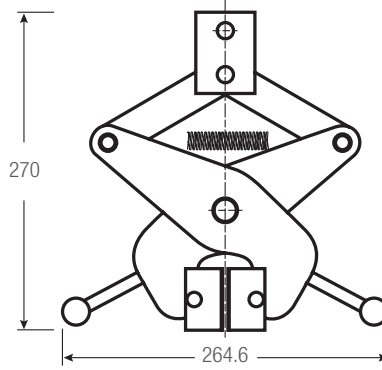
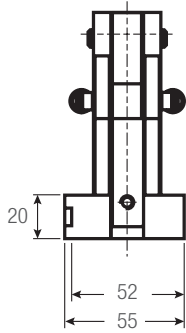

SCISSOR-11-50S-1

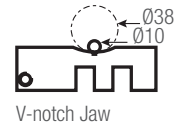
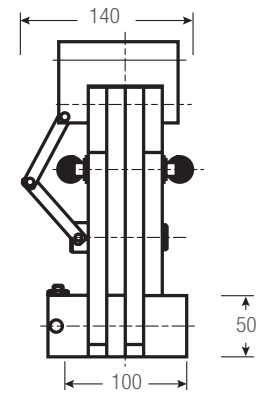

V-notch Jaw

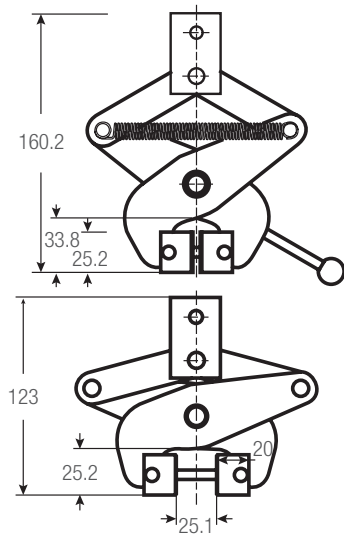

SCISSOR-11-20A-1

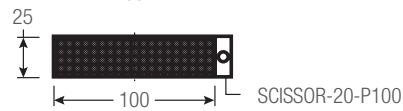
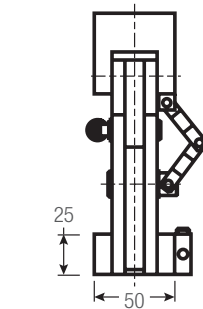

SCISSOR-20-P100

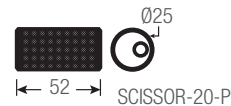

SCISSOR-20-P

SCISSOR FIXTURES

230

STEEL

- For general-purpose tensile testing applications on soft material such as elastomer, plastic, rubber, bones, textiles, etc.
- 20 mm diameter cylindrical jaws
- Operating Temperatures 32° to 266°F (0° to 130°C)



Scissor Fixtures

Model No.	Load Capacity			Jaw Face	Jaw Opening (Max)		Clamping Surface		Weight (each)		Clevis Type mm	Supply
	N	KGF	LBF		in	mm	in	mm	lbs	kgs		
SCISSOR-230S-1	2,000	200	450	Serrated	1.1	28	0.8	20	1.1	0.5	15.9	2

DIMENSIONS

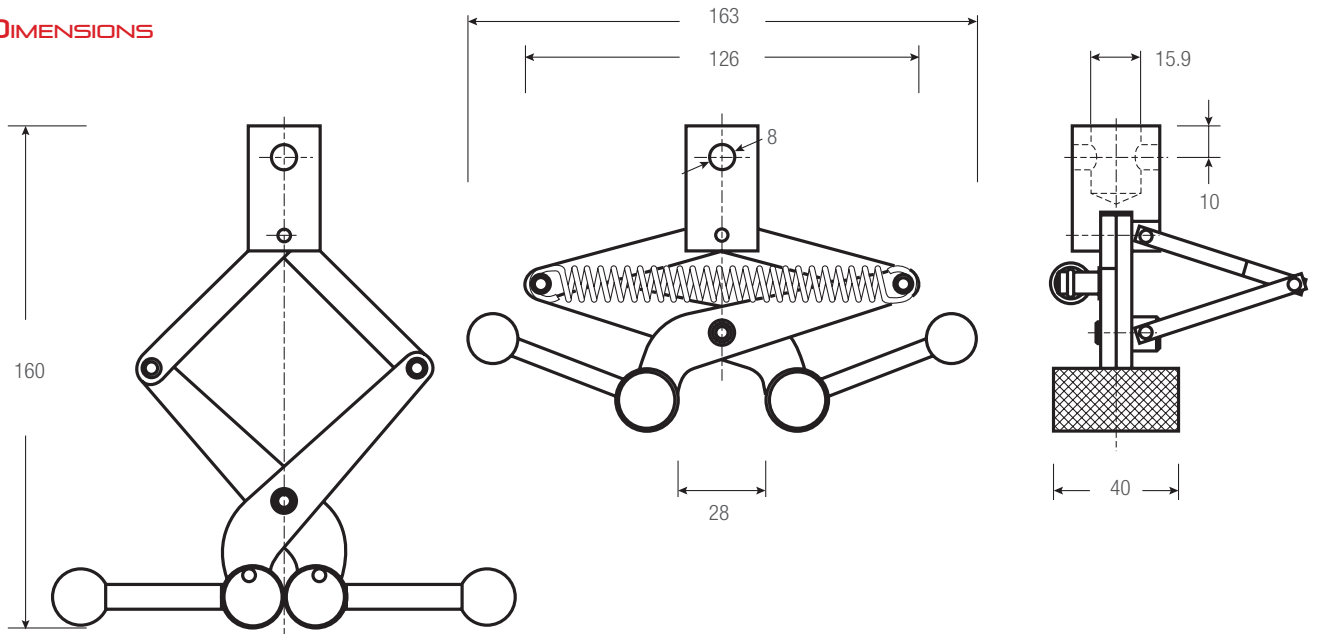

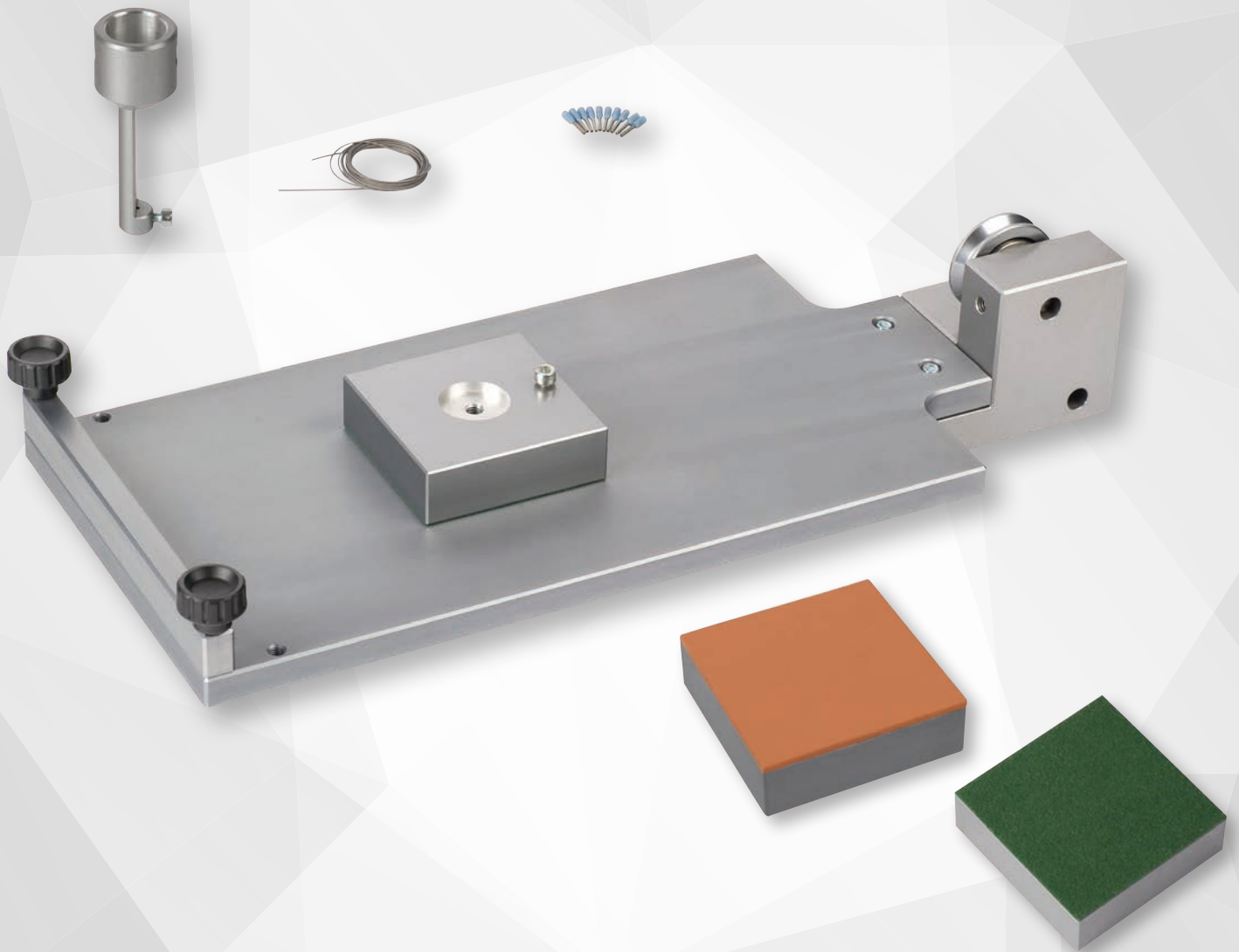

COEFFICIENT OF FRICTION

COEFFICIENT OF FRICTION

These Starrett test fixtures conform to ASTM , TAPPI and ISO application standards for determining the coefficient of friction on films, substrates, ceramics and slip resistant finishes.

Test fixtures include all accessories based on the associated test method.

OPERATION

Coefficient of friction may be measured with two different test fixtures. Both fixtures consist of a horizontal table with a moveable sled having a known mass (typically 200g). Both the table and the sled are covered with the sample under test. A cable connects to the sled and to the load cell sensor, which is attached to the test frame's crosshead. A pulley guides the cable movement ensuring that the force is measured axially.

The static friction is measured as the first maximum force. The kinetic or dynamic friction is measured as an average force between two points normally measured after the static friction point.

Coefficient of friction is the measured force divided by the mass of the sled used.

TESTING STANDARDS

These testing standards may be used with Starrett COF test fixtures:

- ASTM D1894
- TAPPI T549
- ISO 8295
- DIN 55375

COF-ASTM

STEEL, NICKEL FINISH

- For COF testing per ASTM-D1894 or TAPPI-T549
- 200g rubber-faced sled mass
- Operating Temperatures 32° to 158°F (0° to 70°C)

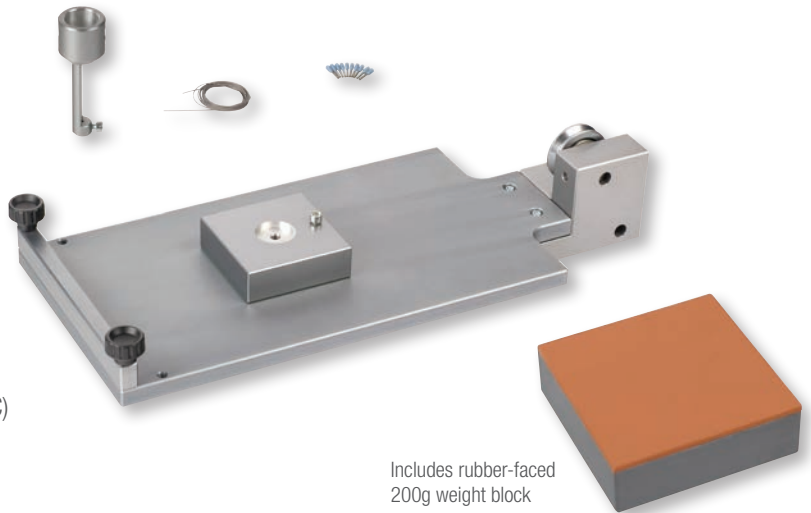

Includes rubber-faced 200g weight block

Coefficient of Friction Fixture												
Model No.	Load Capacity			Sled Mass (grams)	Sled Surface Material	Platen Dimensions		Weight (each)		Clevis Type	Supply	
	N	KGF	LBF			in	mm	lbs	kgs			
COF62-1	500	50	110	200	Rubber	10.6 x 5.9	270 x 150	7.8	3.5	15.9	1	

DIMENSIONS

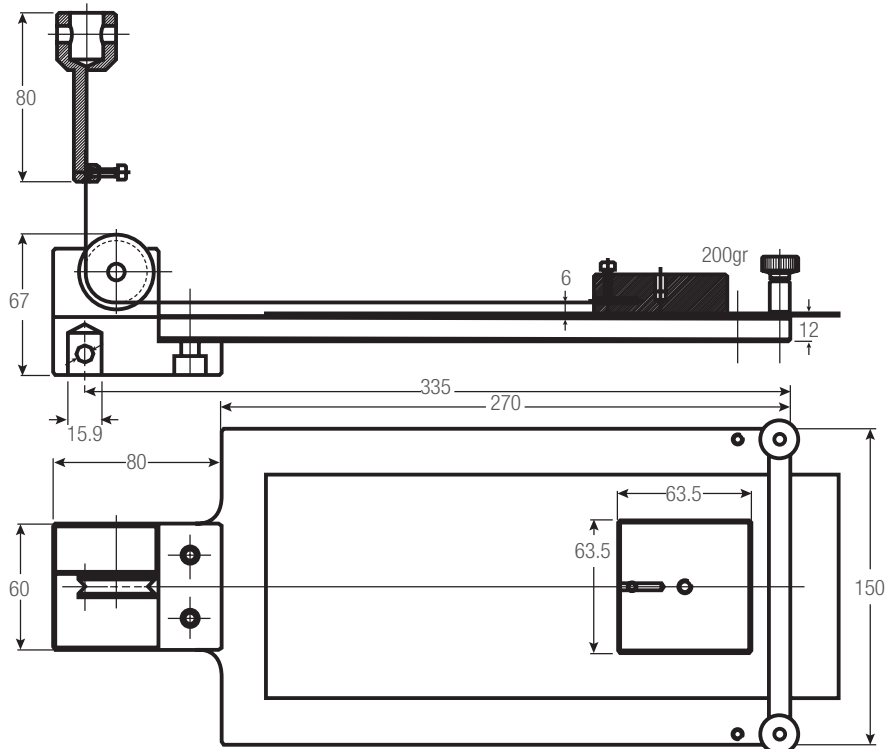

COEFFICIENT OF FRICTION

COF-ISO

STEEL, NICKEL FINISH

- For COF testing per ISO 8295 and DIN 53375
- 200g felt-faced sled mass
- Operating Temperatures 32° to 158°F (0° to 70°C)

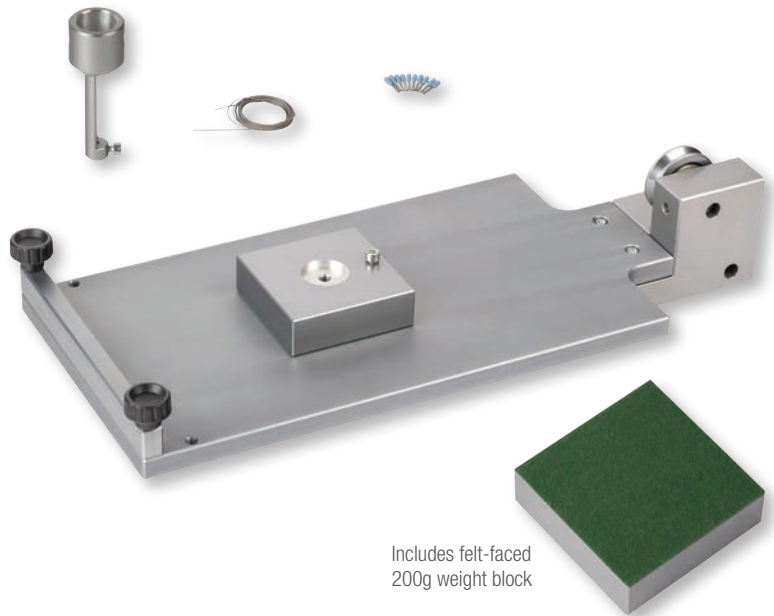

Coefficient of Friction Fixture

Model No.	Load Capacity			Sled Mass (grams)	Sled Surface Material	Platen Dimensions		Weight (each)		Clevis Type mm	Supply
	N	KGF	LBF			in	mm	lbs	kgs		
COF62F-1	500	50	110	200	Felt	10.6 x 5.9	270 x 150	7.8	3.5	15.9	1

DIMENSIONS

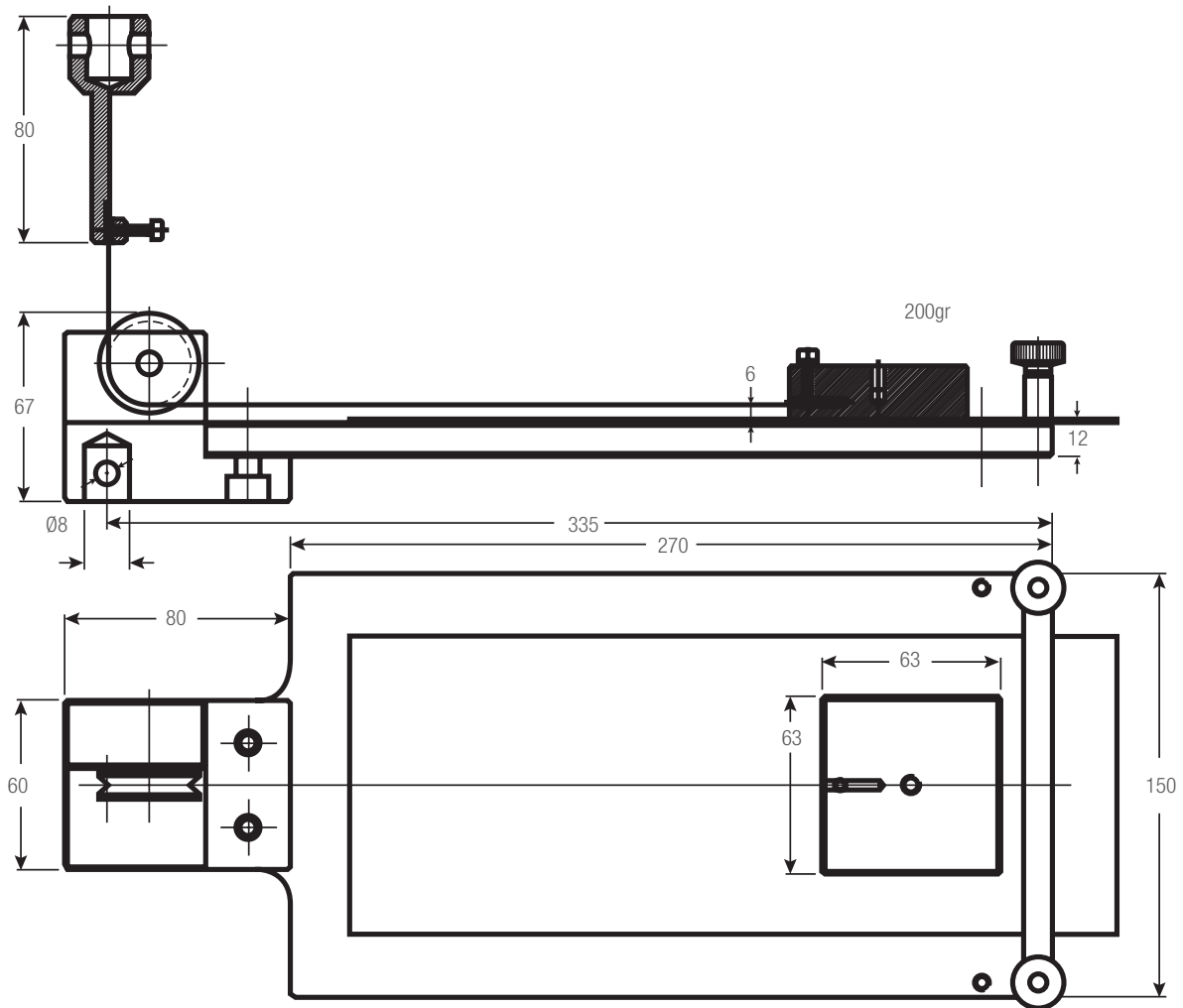



PRECISION MAKES THE DIFFERENCE

**YOU'VE HEARD OF THE
MOTHER OF INVENTION**

**NOW MEET THE FATHER
OF INNOVATION**

The L.S. Starrett Company was founded by Laroy Sunderland Starrett in 1880 who had patented the first combination square in 1878. Since then, we've been following in his footsteps, creating the kind of precision tools, gages and instruments that have made the name "Starrett" synonymous with "innovation." Laroy Starrett set very high standards and we steadfastly maintain them today.

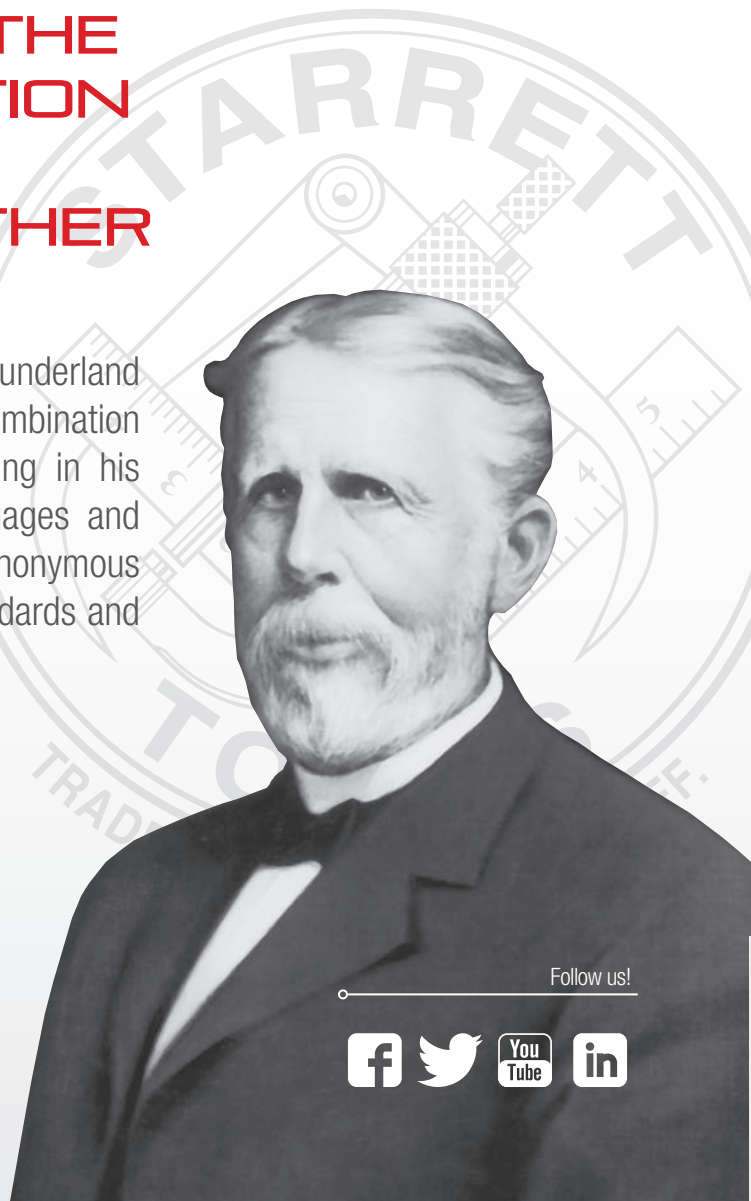

Starrett®

(978) 249-3551 • starrett.com

Follow us!





FOOD TEXTURE FIXTURES

FOOD TEXTURE ANALYSIS FIXTURES

Starrett can supply a variety of testing fixtures for food texture testing applications. Shear, brittleness, softness, crispness are all qualities that can be measured using Starrett test fixtures.

All fixtures are made of corrosion resistant and durable materials.

OPERATION

Various food products are tested for properties such as shear strength, brittleness, crispness, ripeness and more. Using these test fixtures, users can assess the food product's characteristics relative to how food changes physical state during consumption- chewing, shearing, tearing.

TESTING STANDARDS

There are a variety of testing standards for different types of food products from solid and semi-solid items to baked goods, meats, dairy products, confectioneries, pastas and more. Contact your Starrett representative for more information about your specific testing method and the available test fixtures.



Food Texture Fixtures						
Model No.	Load Capacity			Cell Size	No. of Blades	Blade Thickness
	N	KGF	LBF			
SHEAR-KRAMER-70	500	50	110	70 x 70	10	3 mm
SHEAR-KRAMER-120	500	50	110	120 x 120	9	5 mm
SHEAR-WB	2,000	200	450	-	1	1 mm

FOOD TEXTURE ANALYSIS FIXTURES

These shear test fixtures are designed especially for determining food texture characteristics such as tenderness, toughness, etc. They mount to a 15.9mm clevis and are secured with a locking ring and grip pin.

KRAMER SHEAR BLADE FIXTURE

STAINLESS STEEL

- For general-purpose compression applications on small fruits, vegetables, meats, etc.
- Stainless steel V2A blades and fixture for easy cleaning
- Operating Temperatures -112° to 356°F (-80° to 180°C)

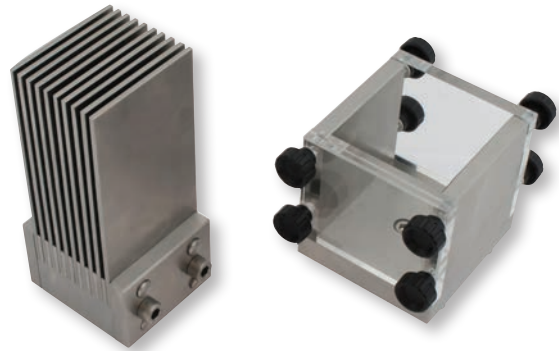

Food Texture Fixtures												
Model No.	Load Capacity			Cell Size		Blade Thickness		No. of Blades	Weight (each)		Clevis Type mm	Supply
	N	KGF	LBF	in	mm	in	mm		lbs	kgs		
SHEAR-KRAMER-70	500	50	110	2.75 x 2.75	70 x 70	0.12	3	10	15.4	7.0	15.9	1

DIMENSIONS

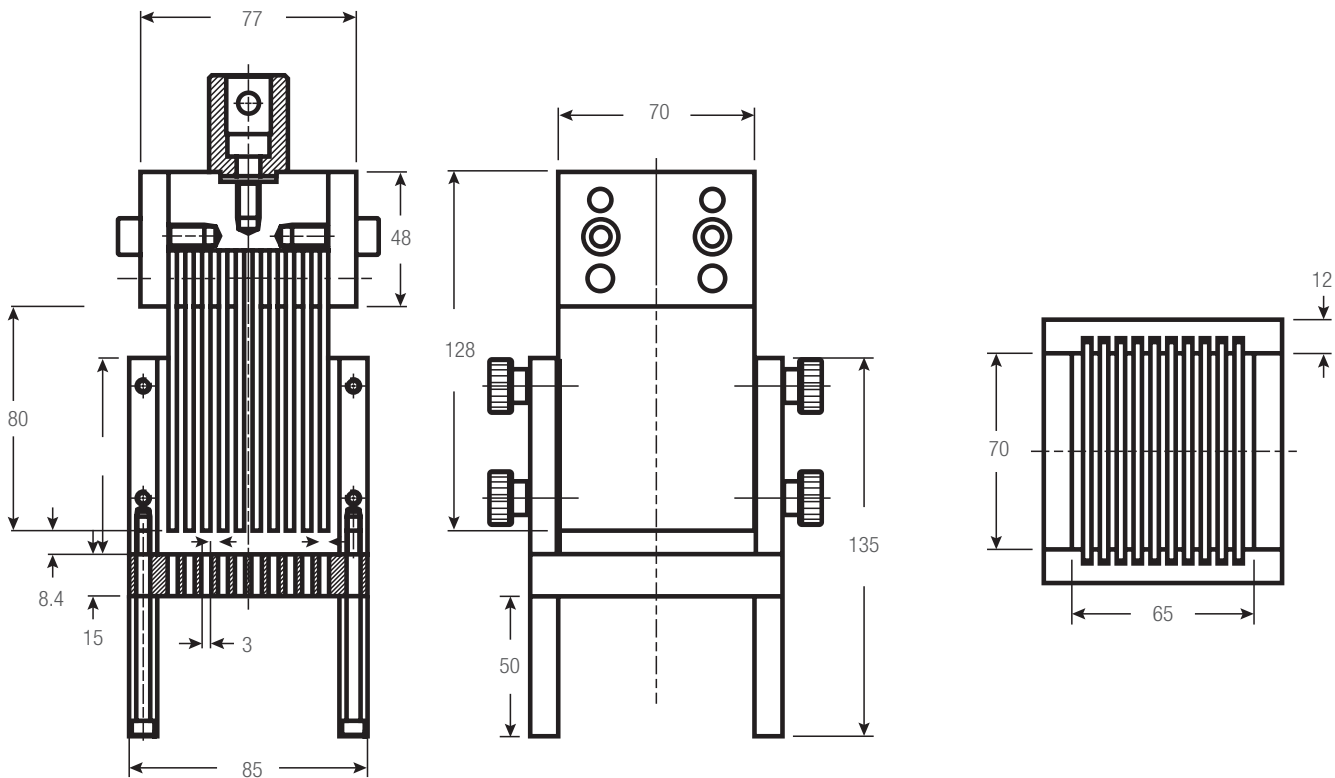

FOOD TEXTURE ANALYSIS FIXTURES

KRAMER SHEAR BLADE FIXTURE

STAINLESS STEEL

- For general-purpose compression applications on small fruits, vegetables, meats, etc.
- Stainless steel V2A blades and fixture for easy cleaning
- Operating Temperatures -112° to 356°F (-80° to 180°C)



Food Texture Fixtures												
Model No.	Load Capacity			Cell Size		Blade Thickness		No. of Blades	Weight (each)		Clevis Type mm	Supply
	N	KGF	LBF	in	mm	in	mm		lbs	kgs		
SHEAR-KRAMER-120	500	50	110	4.72 x 4.72	120 x 120	0.2	5	9	30.8	14.0	15.9	1

DIMENSIONS

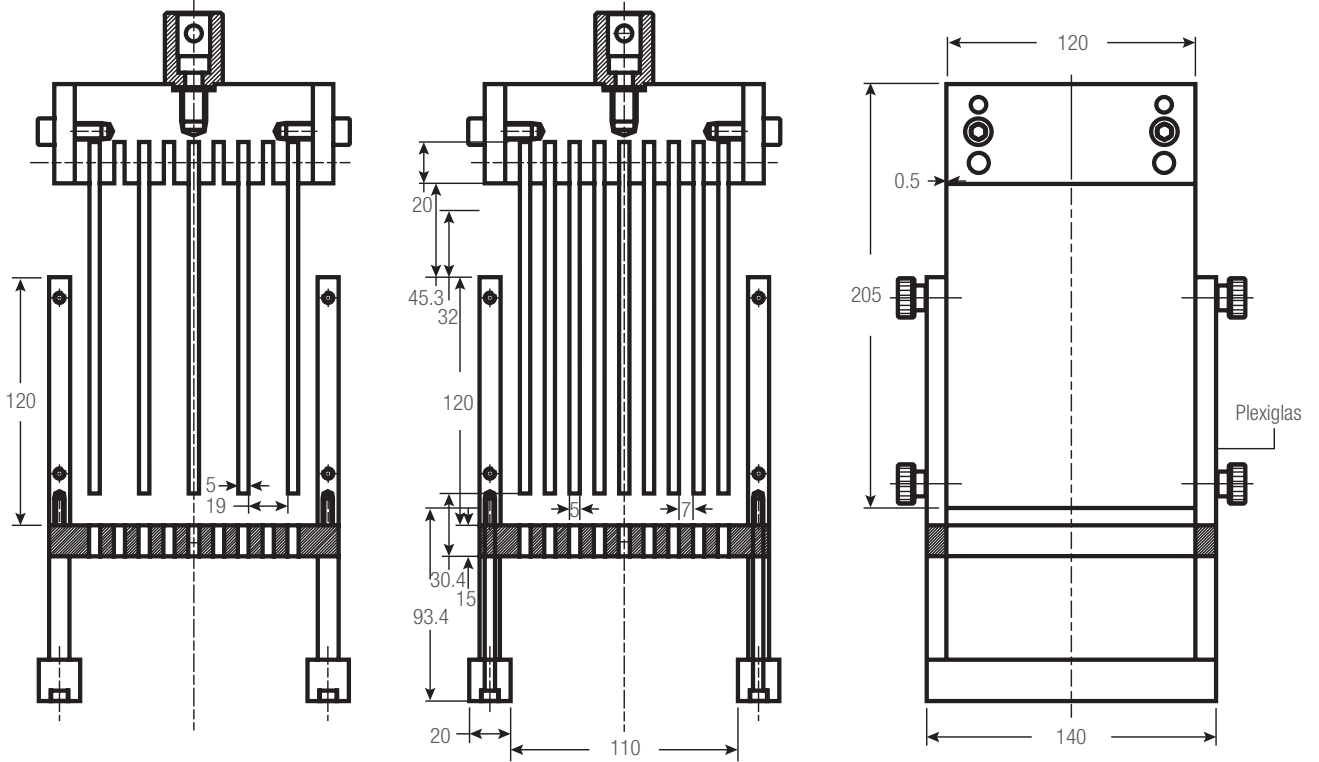

FOOD TEXTURE ANALYSIS FIXTURES

WARNER BRATZLER FIXTURE

STAINLESS STEEL

- For compression/shear applications on meats
- Stainless steel V2A blades and fixture for easy cleaning
- Operating Temperatures -112° to 356°F (-80° to 180°C)

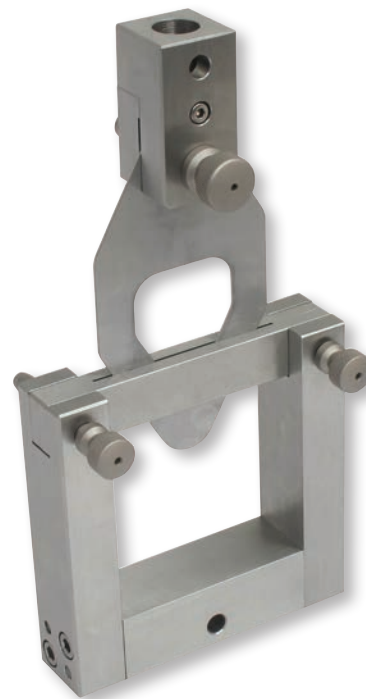

FOOD TEXTURE FIXTURES

Food Texture Fixtures

Model No.	Load Capacity			Blade Thickness		No. of Blades	Weight (each)		Clevis Type	Supply
	N	KGf	LBF	in	mm		lbs	kg		
SHEAR-WB	2,000	200	450	0.04	1	1	4.9	2.2	15.9	1

DIMENSIONS

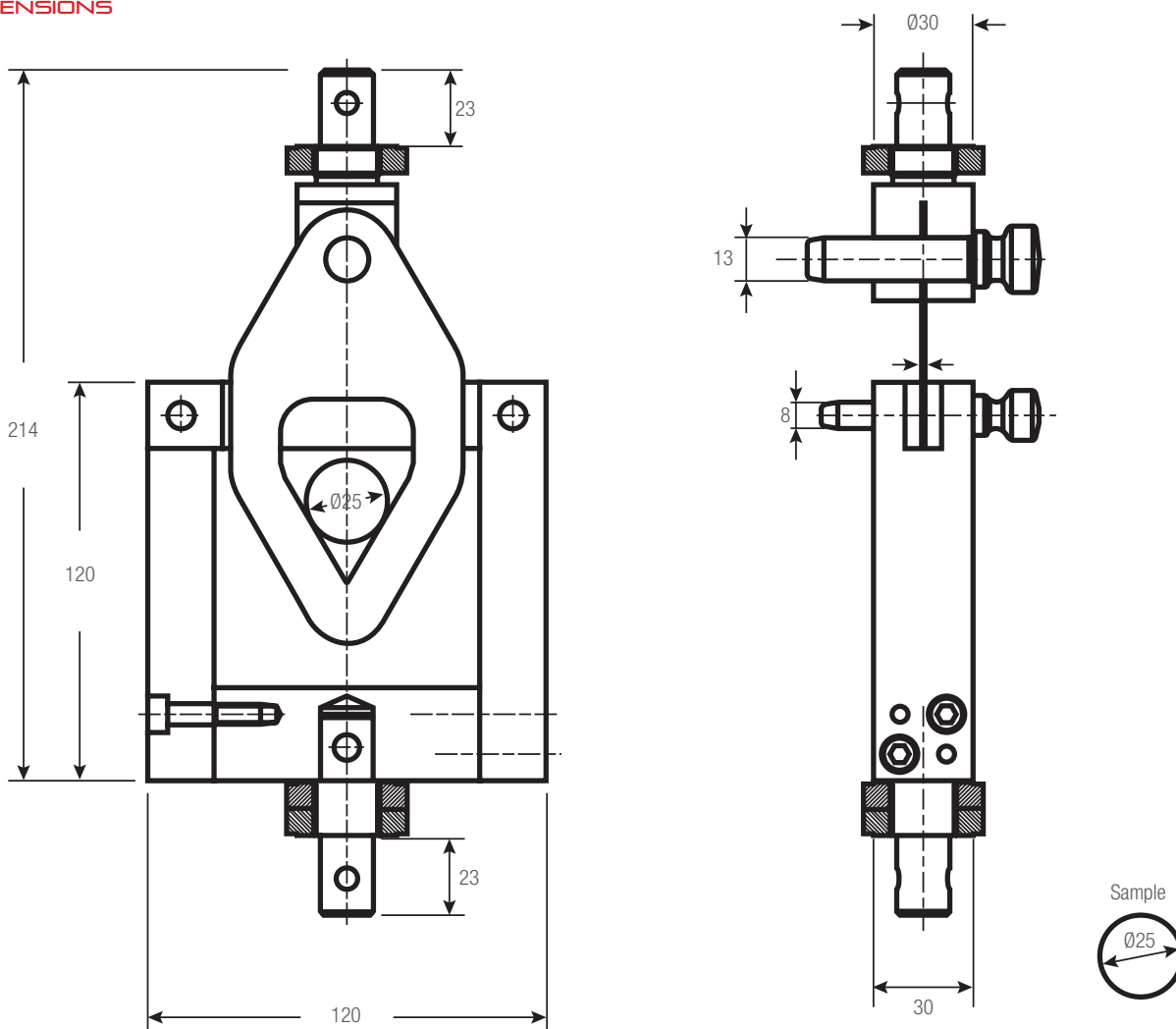



PRECISION MAKES THE DIFFERENCE

FOR OVER 130 YEARS, WITH INNOVATIVE TECHNOLOGIES.

More than 5,000 products including precision tools, vision systems, force measurement systems, non-contact measurement systems, profile projectors, band saw blades, band saw machines, hand tools and power tools accessories.

Read more: www.starrett.com



Starrett®

(978) 249-3551 • starrett.com

Follow us!





HOOK ADAPTERS

CLEVIS HOOKS

Clevis hooks feature a 15.9mm clevis for mounting to a standard Starrett clevis adapter. These hooks have a locking nut so you can rotate and position the hook for proper axial alignment. Hooks are available in a variety of sizes. Steel construction.

CLEVIS HOOKS

STEEL, HARDENED

- For general-purpose tensile testing applications
- Fasten to 15.9mm clevis adapters
- Operating Temperatures 32° to 158°F (0° to 70°C)

Clevis Hooks												
Model No.	Load Capacity			Material	Hook Wire Ø "A"		Hook Length "B"		Hook Radius "C"		Supply each	Clevis Size mm
	N	KGF	LBF		mm	in	mm	in	mm			
HOOK-231-3	350	35	78	Steel	3	2.8	70	0.2	6	1	15.9	
HOOK-231-5	1kN	100	225	Steel	5	3.3	83	0.4	10	1	15.9	
HOOK-231-8	2.5kN	250	560	Steel	8	4.7	120	0.6	16	1	15.9	
HOOK-231-12	6kN	600	1,350	Steel	12	6.4	161.6	0.9	24	1	15.9	

DIMENSIONS

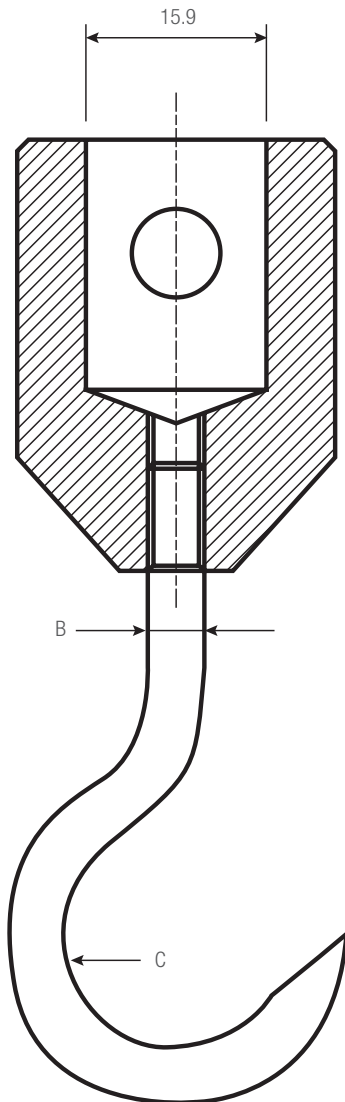

HOOK-231-5



HOOK-231-8



THREADED HOOKS

THREADED HOOKS

ALUMINUM AND STAINLESS STEEL

- For general-purpose tensile testing applications
- Threaded attachment
- Operating Temperatures 32° to 158°F (0° to 70°C)



Threaded Hooks										
Model No.	Load Capacity			Material	Thread Size		Hook Length		Supply	Wire Ø mm
	N	KGF	LBF		Female	Male	in	mm		
MLX-HOOK-XS	50	5	10	Aluminum	M6 x 1 - 6H	-	1.57	40	1	2.5
MLX-HOOK-S	500	50	100	Stainless Steel	-	M6 x 1 - 6g	1.73	44	1	6
MLX-HOOK-M	1500	150	330	Stainless Steel	-	M6 x 1 - 6g	2.6	66	1	6
MLX-HOOK-L	2500	250	500	Stainless Steel	-	M10 x 1.5-6g	3.9	99	1	6
MLX-HOOK-XL	2500	250	500	Stainless Steel	-	M12 x 1.75-6g	3.94	100	1	12

THREADED HOOK SWIVEL ADAPTER

STAINLESS STEEL

- Use with threaded hooks
- Allows for 360° hook rotation
- Operating Temperatures 32° to 158°F (0° to 70°C)

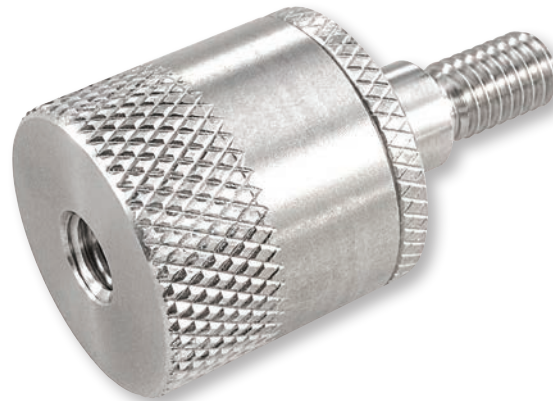

Swivel Adapters									
Model No.	Load Capacity			Thread Size Male Metric	Thread Size Female Metric	Material	Adapter Length (without hook)		Supply
	N	KGF	LBF				in	mm	
MLX-SWIVEL	250	25	56	M6 x 1	M6 x 1-6H	Stainless	2.0	51	1
MLX-SWIVEL-L	2,500	250	550	M10 x 1.5	M10 x 1.5-6H	Stainless	2.54	64.5	1



PRECISION MAKES THE DIFFERENCE

YOUR NAME DEPENDS ON OURS

The CP505E-12 Electronic Protractor is accurate, versatile and easy to use. It eliminates errors from a variety of jobs including complex crown molding work.



Starrett®

(978) 249-3551 • starrett.com

Follow us!





CLEVIS ADAPTERS

CLEVIS ADAPTERS

Clevis adapters are used to secure most of the testing fixtures available for your Starrett systems.

Clevis adapters are available in two diameters: 15.9mm and 31.8mm. The 15.9mm adapters are the most commonly used and are designed for load capacities below 20kN. Loads over 20kN will typically use the 31.8mm clevis.

Special clevis adapters are available for use with Starrett force gages. These adapters thread on to the force gage shaft and allow clevis-style test fixtures to be utilized.



CLEVIS ADAPTER SET

- Includes clevis, locking rings and grip pin
- Threaded attachment
- Operating Temperatures 32° to 158°F (0° to 70°C)

Clevis Sets										
Model No.	Load Capacity			Thread Size Metric	Material	Diameter (Clevis)		Length		Supply
	N	KGF	LBF			in	mm	in	mm	
SPK-CLEVIS-A	50	5	10	M6 x 1-6H	Aluminum	0.626	15.9	1.693	43	1
SPK-CLEVIS-S	1,500	150	330	M6 x 1-6H	Stainless	0.626	15.9	2.205	56	1
SPK-CLEVIS-M	2,500	250	562	M10 x 1.5-6H	Stainless	0.626	15.9	2.362	60	1
SPK-CLEVIS-L	5,000	500	1,124	M12 x 1.75-6H	Stainless	0.626	15.9	2.362	60	1
KIT-CLEVIS15-S-M16	20KN	2,000	4,500	M16 x 2-4H	Stainless	0.626	15.9	2.362	60	1
KIT-CLEVIS31-S-M16	50K	5,000	11,124	M16 x 2-4H	Stainless	1.25	31.7	3.5	89	1

FORCE GAGE ADAPTER SET

- Includes clevis, locking rings and grip pin
- For DFC or DFG digital force gage
- Operating Temperatures 32° to 158°F (0° to 70°C)
- Female thread

Force Gage Sets										
Model No.	Load Capacity			Thread Size Metric	Material	Diameter (clevis)		Supply		
	N	KGF	LBF			in	mm			
SPK-FG-CLEVIS-A	20	2	5	M6 X 1-6H	Aluminum	0.63	15.9	1		
SPK-FG-CLEVIS-S	1,500	150	330	M6 X 1-6H	Stainless Steel	0.63	15.9	1		
SPK-FG-CLEVIS-L	2,500	250	550	M10 X 1.5-6H	Stainless Steel	0.63	15.9	1		

MALE CLEVIS ADAPTER

- Clevis only (no rings or pins)
- Threaded attachment
- Operating Temperatures 32° to 158°F (0° to 70°C)

Clevis Adapters										
Model No.	Load Capacity			Thread Size Metric	Material	Diameter (Clevis)		Length		Supply
	N	KGF	LBF			in	mm	in	mm	
MLX-CLEVIS-A-M6M	50	5	10	M6 x 1-6H	Aluminum	0.626	15.9	1.693	43	1
MLX-CLEVIS-S-M6M	1,500	150	330	M6 x 1-6H	Stainless	0.626	15.9	2.205	56	1
MLX-CLEVIS-S-M10M	2,500	250	562	M10 x 1.5-6H	Stainless	0.626	15.9	2.362	60	1
MLX-CLEVIS-S-M12M	5,000	500	1,124	M12 x 1.75-6H	Stainless	0.626	15.9	2.362	60	1

CLEVIS ADAPTERS

FEMALE CLEVIS ADAPTER

- Use with Force Gages
- Female Threaded attachment only, no locking rings/pins
- Operating Temperatures 32° to 158°F (0° to 70°C)



Clevis Adapters - Force Gage

Model No.	Load Capacity			Thread Size Metric	Material	Diameter		Length		Supply
	N	KGF	LBF			in	mm	in	mm	
MLX-CLEVIS-FA-M6	20	2	5	M6 x 1-6H	Aluminum	0.626	15.9	1.457	37	1
MLX-CLEVIS-FS-M6	1,500	150	330	M6 x 1-6H	Stainless	0.626	15.9	1.890	48	1
MLX-CLEVIS-FS-M10	2,500	250	550	M10 x 1.5-6H	Stainless	0.626	15.9	1.890	48	1

LOCKING RINGS

- Use with Clevis Adapters
- Threaded attachment
- Operating Temperatures 32° to 158°F (0° to 70°C)



Locking Rings

Model No.	Load Capacity			Thread Size Metric	Material	Diameter		Thickness		Supply
	N	KGF	LBF			in	mm	in	mm	
MLX-RING-A	50	5	10	M20	Aluminum	0.25	31.75	0.236	6.0	1
MLX-RING-S	50K	5,000	11,000	M24	Stainless	1.5	38.1	0.47	11.94	1

GRIP PINS

- Use with Clevis Adapters
- Threaded attachment
- Operating Temperatures 32° to 158°F (0° to 70°C)



Grip Pins

Model No.	Load Capacity			Length		Material	Diameter		Supply
	N	KGF	LBF	in	mm		in	mm	
MLX-PIN-A	50	5	10	2.756	70	Aluminum	0.311	7.9	1
MLX-PIN-S	50K	5,000	11,000	2.756	70	Stainless	0.311	7.9	1

SPANNER WRENCH

- Use to tighten Stainless Steel Rings

Spanner Wrench

Model No.	Length		Material	Supply
	in	mm		
L1-SPANNER	7.5	190	Steel	1



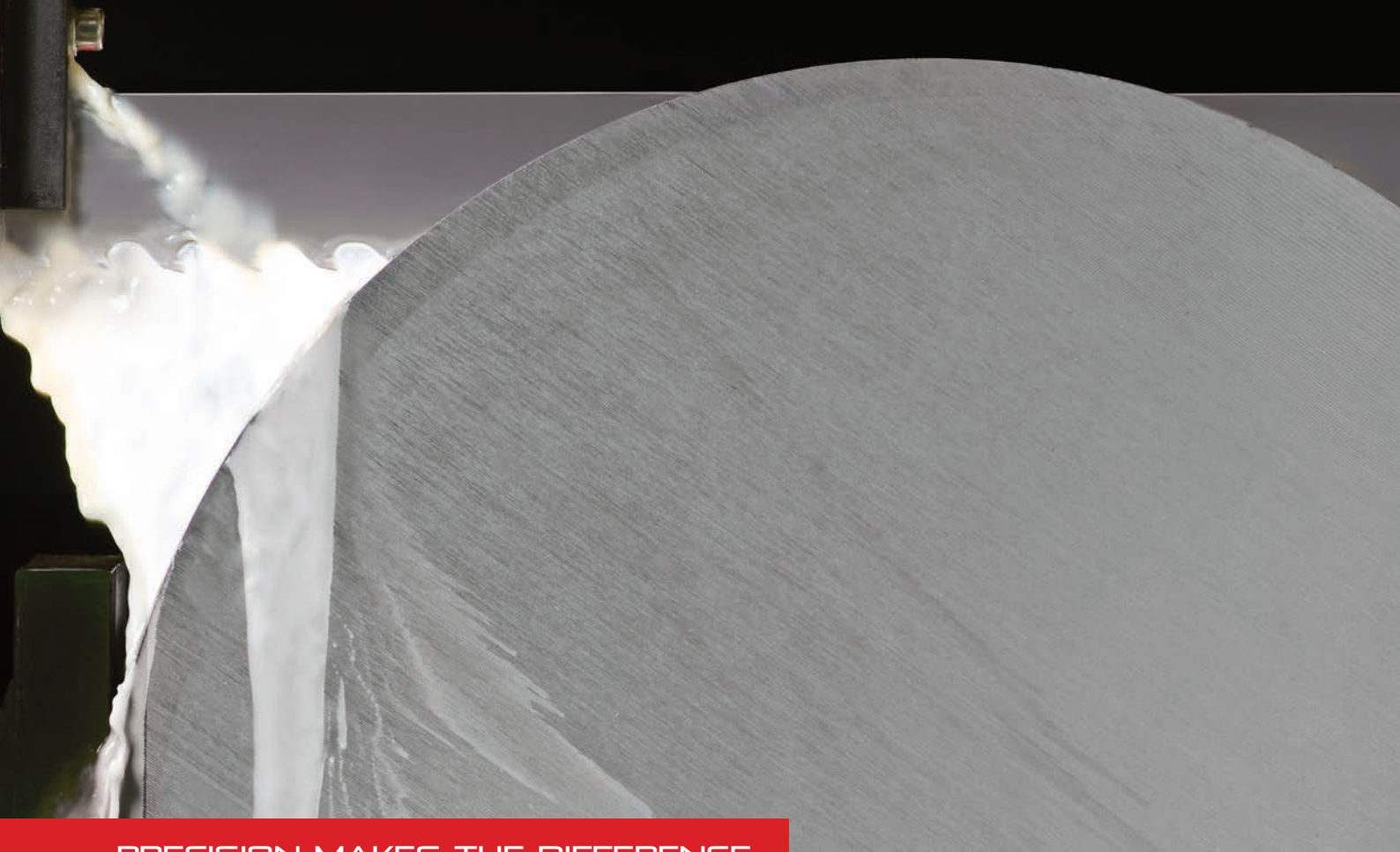

PRECISION MAKES THE DIFFERENCE

HIGH PRODUCTIVITY AND LONGER LIFE

For cutting hard materials!

The Advanz™ MC5 utilizes a multiple chip grind with a high/low tooth sequence. The chip load is spread out over more teeth to facilitate longer life.

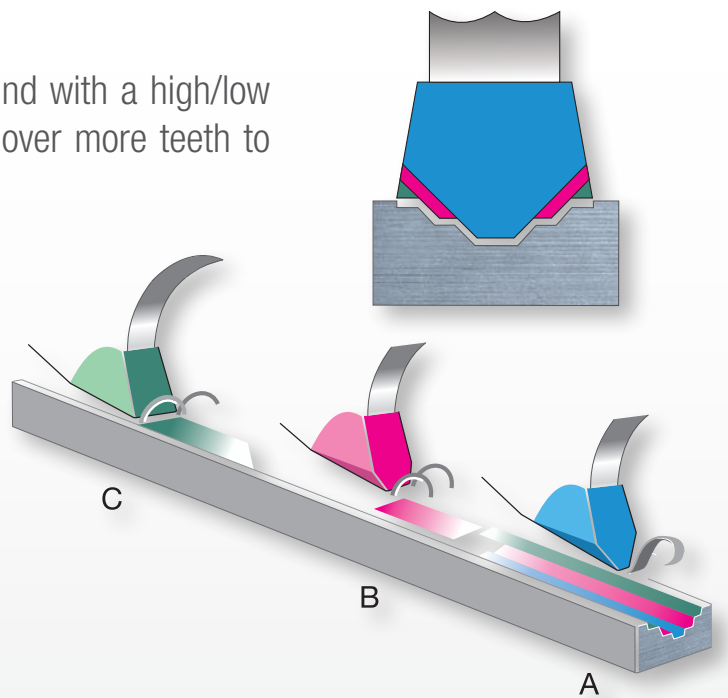

Starrett®

(978) 249-3551 • starrett.com

Follow us!





FORCE GAGE ADAPTERS

FORCE GAGE ADAPTERS

These adapters are supplied standard with Starrett force gages. They may also be used with thread adapters and various load cell sensors available from Starrett.

Gage adapters include flats, notches, chisels, points and rods.

FLAT ADAPTERS

- For general-purpose compression testing applications
- Threaded attachment
- Operating Temperatures 32° to 158°F (0° to 70°C)

Flat Adapters											
Model No.	Load Capacity			Thread Size Metric	Material	Diameter (Flat)		Length		Supply	OD
	N	KGf	LBF			in	mm	in	mm		
MLX-FLAT-A	20	2	5	M6 x 1-6H	Aluminum	0.5	12	0.5	12	1	1/2"
MLX-FLAT-S	1,500	150	330	M6 x 1-6H	Stainless	0.5	12	0.5	12	1	1/2"
MLX-FLAT-L	2,500	250	550	M10 x 1.5-6H	Stainless	0.75	19	0.875	22	1	3/4"
MLX-FLAT-XL	5,000	500	1,100	M12 x 1.75-6H	Stainless	0.75	19	0.875	22	1	3/4"



NOTCH ADAPTERS

- For general-purpose compression testing applications
- Threaded attachment, 90° notch
- Operating Temperatures 32° to 158°F (0° to 70°C)

V-Notch Adapters											
Model No.	Load Capacity			Thread Size Metric	Material	Diameter		Length		Supply	OD
	N	KGf	LBF			in	mm	in	mm		
MLX-NOTCH-A	20	2	5	M6 x 1-6H	Aluminum	0.375	9.5	0.625	15.9	1	3/8"
MLX-NOTCH-S	1,500	150	330	M6 x 1-6H	Stainless	0.375	9.5	0.625	15.9	1	3/8"
MLX-NOTCH-L	2,500	250	550	M10 x 1.5-6H	Stainless	0.625	15.9	1.125	28.6	1	5/8"
MLX-NOTCH-XL	5,000	500	1,100	M12 x 1.75-6H	Stainless	0.625	15.9	1.125	28.6	1	5/8"

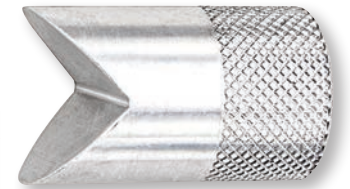

CHISEL ADAPTERS

- For general-purpose compression testing applications
- Threaded attachment, 60° chisel point
- Operating Temperatures 32° to 158°F (0° to 70°C)

Chisel Adapters											
Model No.	Load Capacity			Thread Size Metric	Material	Diameter		Length		Supply	OD
	N	KGf	LBF			in	mm	in	mm		
MLX-CHISEL-A	20	2	5	M6 x 1-6H	Aluminum	0.375	9.5	0.625	15.9	1	0.475
MLX-CHISEL-S	1,500	150	330	M6 x 1-6H	Stainless	0.375	9.5	0.625	15.9	1	3/8"
MLX-CHISEL-L	2,500	250	550	M10 x 1.5-6H	Stainless	0.625	15.9	1.125	28.6	1	5/8"
MLX-CHISEL-XL	5,000	500	1,100	M12 x 1.75-6H	Stainless	0.625	15.9	1.125	28.6	1	5/8"

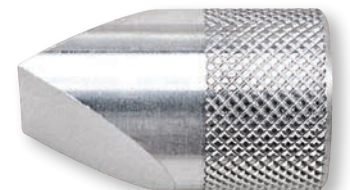

POINT ADAPTERS

- For general-purpose compression testing applications
- Threaded attachment
- Operating Temperatures 32° to 158°F (0° to 70°C)

Point Adapters											
Model No.	Load Capacity			Thread Size Metric	Material	Diameter		Length		Supply	OD
	N	KGf	LBF			in	mm	in	mm		
MLX-POINT-A	20	2	5	M6 x 1-6H	Aluminum	0.375	9.5	0.625	15.9	1	3/8"
MLX-POINT-S	1,500	150	330	M6 x 1-6H	Stainless	0.375	9.5	0.625	15.9	1	3/8"
MLX-POINT-L	2,500	250	550	M10 x 1.5-6H	Stainless	0.625	15.9	1.125	28.6	1	5/8"
MLX-POINT-XL	5,000	500	1,100	M12 x 1.75-6H	Stainless	0.625	15.9	1.125	28.6	1	5/8"



EXTENSION RODS

These threaded extension rods come in a variety of lengths and materials. Use to affix gage adapters or other forms of threaded test fixtures.

Rods can be threaded to a force gage or load cell sensor.

EXTENSION RODS

- Provides for a longer testing length
- Threaded attachment, multiple lengths available
- Operating Temperatures 32° to 158°F (0° to 70°C)

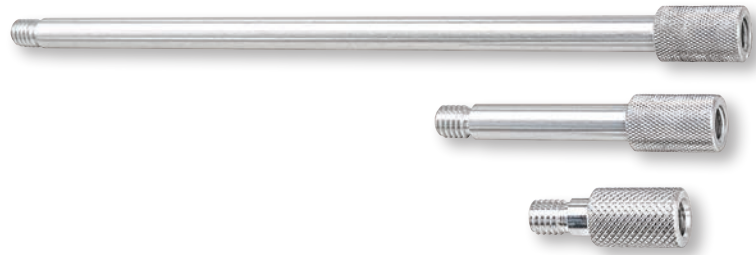

Extension Rods									
Model No.	Load Capacity			Thread Size "A"	Thread Size "B"	Material	Length		Supply
	N	KGF	LBF	Metric	Metric		in	mm	
MLX-ROD-A1	50	5	10	M6 x 1-6H	M6 x 1-6g	Aluminum	1.0	25.4	1
MLX-ROD-A2	50	5	10	M6 x 1-6H	M6 x 1-6g	Aluminum	2.0	50.8	1
MLX-ROD-A6	50	5	10	M6 x 1-6H	M6 x 1-6g	Aluminum	6.0	152.4	1
MLX-ROD-S1	1,500	150	330	M6 x 1-6H	M6 x 1-6g	Stainless	1.0	25.4	1
MLX-ROD-S2	1,500	150	330	M6 x 1-6H	M6 x 1-6g	Stainless	2.0	50.8	1
MLX-ROD-S6	1,500	150	330	M6 x 1-6H	M6 x 1-6g	Stainless	6.0	152.4	1
MLX-ROD-L2	2,500	250	550	M10 x 1.5-6H	M10 x 1.5-6g	Stainless	2.0	50.8	1
MLX-ROD-L6	2,500	250	550	M10 x 1.5-6H	M10 x 1.5-6g	Stainless	6.0	152.4	1
MLX-ROD-XL6	5,000	500	1,100	M12 x 1.75-6H	M12 x 1.75-6g	Stainless	6.0	152.4	1

FORCE GAGE ACCESSORY KITS

These force gage kits include a hook, flat, notch, chisel, point and rod.

FORCE GAGE KITS

- Includes each force gage accessory by type
- Threaded attachment
- Operating Temperatures 32° to 158°F (0° to 70°C)



Force Gage Accessory Kits										
Model No.	Load Capacity			Force Gage Adapters						Supply
	N	KGF	LBF	Hook	Flat	Notch	Chisel	Point	Rod	
SPK-FG-A	50	5	10	MLX-HOOK-XS	MLX-FLAT-A	MLX-NOTCH-A	MLX-CHISEL-A	MLX-POINT-A	MLX-ROD-A6	1
SPK-FG-S	500	50	110	MLX-HOOK-S	MLX-FLAT-S	MLX-NOTCH-S	MLX-CHISEL-S	MLX-POINT-S	MLX-ROD-S6	1
SPK-FG-M	1,500	150	330	MLX-HOOK-M	MLX-FLAT-S	MLX-NOTCH-S	MLX-CHISEL-S	MLX-POINT-S	MLX-ROD-S6	1
SPK-FG-L	2,500	250	550	MLX-HOOK-L	MLX-FLAT-L	MLX-NOTCH-L	MLX-CHISEL-L	MLX-POINT-L	MLX-ROD-L6	1

THREADED ADAPTERS

These threaded adapters are used to mate dissimilar threaded connectors. Included are couplers, male-to-male and male-to-female thread adapters.

COUPLERS

- For mating two male threaded adapters
- Threaded attachment
- Operating Temperatures 32° to 158°F (0° to 70°C)

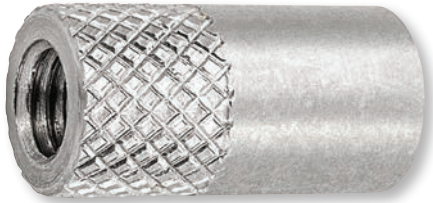

Female to Female Threaded Couplers

Model No.	Dimensions			Supply
	Length	Thread A	Thread B	
MLX-25037	0.75 in	#10-32 UNF-2B	1/4-28 UNF-2B	1
MLX-25038	0.75 in	#10-32 UNF-2B	M6 x 1-6H	1
MLX-25039	1.0 in	5/16-18 UNF-2B	M6 x 1-6H	1
MLX-25040	0.75 in	1/4-28 UNF-2B	M6 x 1-6H	1
MLX-25041	1.25 in	5/16-18 UNF-2B	M10 x 1.5-6H	1
MLX-25042	1.25 in	1/2-20 UNF-2B	M10 x 1.5-6H	1
MLX-25064	0.75 in	M6 x 1-6H	M6 x 1-6H	1
MLX-25065	1.25 in	M10 x 1.5-6H	M10 x 1.5-6H	1
MLX-25066	0.75 in	#10-32 UNF-2B	#10-32 UNF-2B	1
MLX-25067	0.75 in	1/4-28 UNF-2B	1/4-28 UNF-2B	1
MLX-25068	1.00 in	5/16-18 UNF-2B	5/16-18 UNF-2B	1
MLX-25069	1.25 in	1/2-20 UNF-2B	1/2-20 UNF-2B	1

SET SCREWS

- For general thread adapters
- Threaded attachment
- Operating Temperatures 32° to 158°F (0° to 70°C)



Set Screws

Model No.	Dimensions			Supply
	Length	Thread		
MLX-51000195	20mm	M4 x 0.7		1
MLX-51000187	25mm	M6 x 1		1
MLX-51000188	25mm	M10 x 1.5		1
MLX-51000196	25mm	M12 x 1.75		1

FEMALE TO MALE THREAD ADAPTER

- Has one female and one male thread
- Threaded attachment
- Operating Temperatures 32° to 158°F (0° to 70°C)



Female to Male Thread Adapters

Model No.	Dimensions			Supply
	Length	Female Thread	Male Thread	
MLX-25043	0.75 in	#10-32 UNF-2B	M6 x 1-6g	1
MLX-25044	0.75 in	M6 x 1-6H	#10-32 UNF-2A	1
MLX-25045	0.75 in	1/4-28 UNF-2B	M6 x 1-6g	1
MLX-25046	0.75 in	M6 x 1-6H	1/4-28 UNF-2A	1
MLX-25047	1.00 in	5/16-18 UNC-2B	M6 x 1-6g	1
MLX-25048	0.875 in	M6 x 1-6H	5/16-18 UNC-2A	1
MLX-25049	1.125 in	5/16-18 UNC-2B	M10 x 1.5-6g	1
MLX-25050	1.25 in	M10 x 1.5-6H	5/16-18 UNC-2A	1
MLX-25051	1.25 in	1/2-2 UNF-2B	M10 x 1.5-6g	1
MLX-25052	1.25 in	M10 x 1.5-6H	1/2-20 UNF-2A	1

MALE TO MALE THREAD ADAPTER

- Has two dissimilar male threads
- Threaded attachment
- Operating Temperatures 32° to 158°F (0° to 70°C)



Male to Male Thread Adapter

Model No.	Dimensions			Supply
	Length	Thread A	Thread B	
MLX-25053	0.75 in	M4 x 0.7-6g	M6 x 1-6g	1
MLX-25054	0.875 in	M10 x 1.5-6g	M6 x 1-6g	1
MLX-25055	0.75 in	#10-32 UNF-2A	1/4-28 UNF-2A	1
MLX-25056	0.875 in	#10-32 UNF-2A	5/16-18 UNC-2A	1
MLX-25057	0.875 in	5/16-18 UNC-2A	1/4-28 UNF-2A	1
MLX-25058	0.875 in	1/4-28 UNF-2A	1/2-20 UNF-2A	1
MLX-25059	1.00 in	5/16-18 UNC-2A	1/2-20 UNF-2A	1
MLX-25060	0.75 in	#10-32 UNF-2A	M6 x 1-6g	1
MLX-25061	0.75 in	1/4-28 UNF-2A	M6 x 1-6g	1
MLX-25062	1.00 in	5/16-18 UNC-2A	M10 x 1.5-6g	1
MLX-25063	1.00 in	1/2-20 UNF-2A	M10 x 1.5-6g	1



CABLES

CABLES

Listed below are the cables used with all Starrett force gages and Lx systems.

Systems using L1, L2 Plus and L3 software interface and communicate with their associated computer using USB communications.

The DFG and DFC force gages use a USB cable for charging the internal lithium ion battery. The USB cable may also be used with communicating to a computer.

When the DFC force gage is used as a controller with the FMM test frames, communications between the DFC and the FMM using the L1-CONTROL cable.



USB CABLES

- Interface cable between the Starrett test frame and the personal computer operating L1, L2, S2, L2 Plus and L3 software.
- Interface cable between Starrett force gage and a personal computer.
- Cable used for charging the Starrett force gage internal battery.

USB Cables							
Model No.	Interface Between Devices	Type	Connector		Length		Supply
			A	B	in	mm	
L1-USB	DFC and DFG Force Gage	USB 2.0	USB-A	USB-B Micro	36	915	1
12405-0	AIO PC to FMM, FMS, MMS, FMD and MMD Test Frames	USB 2.0	USB-A	USB-B	72	1,830	1

Shown: DFC force gage shown with L1-USB cable. Cable is supplied standard.

L1-CONTROL CABLE

- Interface cable between the DFC force gage and the FMM test frame.
- Bi-directional control
- Charges the DFC force gage when connected to a powered FMM test frame.



D-Sub Style Cables							
Model No.	Interface Between Devices	Type	Connector		Length		Supply
			A	B	in	mm	
L1-CONTROL	DFC Gage to FMM Test Frame	D-sub	9 Pin Female	9 Pin Male	74	1,880	1

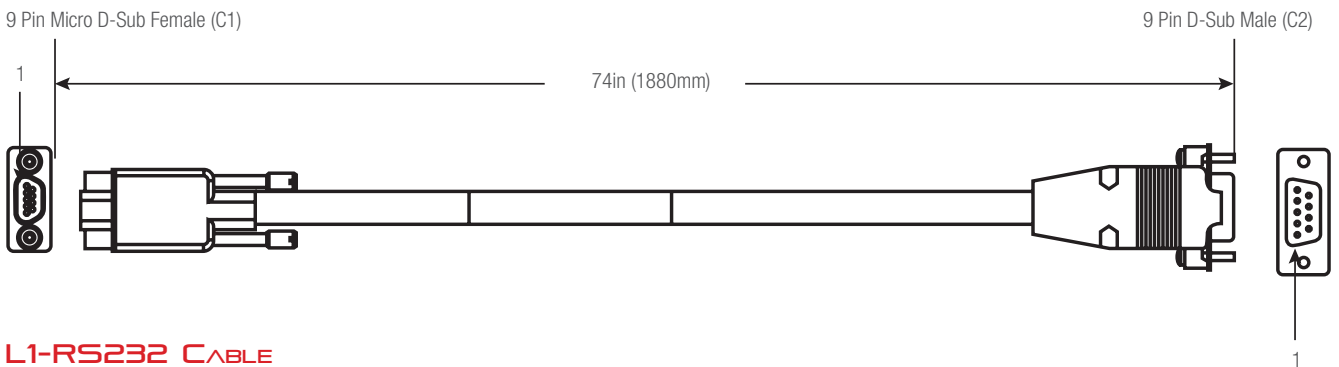

L1-RS232 CABLE

- Interface cable between the FMM test frame and a device using RS-232

D-Sub Style Cables							
Model No.	Interface Between Devices	Type	Connector		Length		Supply
			A	B	in	mm	
L1-RS232	FMM Test Frame to RS-232 Device	D-sub	9 Pin Female	9 Pin Female	74	1,880	1

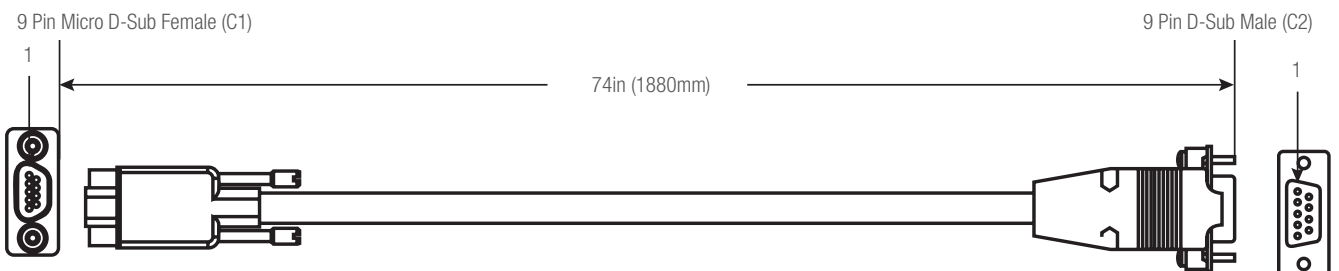



**GAGE ADAPTER PLATES AND
MOUNTING BLOCKS**

ADAPTER PLATES

These adapter plates are used with non-Starrett digital force gages. They allow some competitive force gages to be used with Starrett test frames. Please consult with your Starrett representative before ordering to ensure these plates are compatible with your non-Starrett force gage.

FORCE GAGE ADAPTER PLATES

- Includes mounting block
- Ensures proper alignment on a Starrett test frame

Gage Adapter Plates			
Model No.	Use with this brand Force Gage	Model Type	Supply
MLX-FG-CHAT	Chatillon	DFX, DFE, DFS, DFE2, DFS2	1
MLX-FG-IMAD	Imada	ZT, DS2	1
MLX-FG-MARK	Mark-10	Series 7, 5, 4	1
MLX-FG-MECM	Mecmesin	AFG, BFG	1
MLX-FG-SHIM	Shimpo	FG-7000, FGV-XY, FGE	1



Chatillon® adapter plate



Mark-10® adapter plate

MOUNTING BLOCKS

These mounting blocks are used with the FMM model test frames. They are used with the BLC Load Cell sensors and the DFG and DFC force gages.

The mounting blocks ensure correct alignment and proper axial positioning.

MOUNTING BLOCKS

- For Starrett Force Gages and BLC Load Cells
- Ensures proper alignment on a Starrett FMM test frame
- Includes all mounting hardware



BLC adapter plate

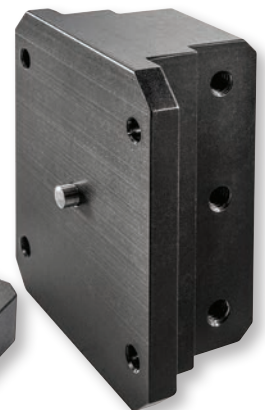

DFG and DFC adapter plate

Mounting Blocks		
Model No.	Description	Supply
SPK-FG-BLOCK	Used to mount Starrett DFC or DFG Force Gage to FMM test frame	1
SPK-BLC-BLOCK	Used to mount any BLC Load Cell Sensors to the FMM test frame	1



TESTER ACCESSORIES

TESTER ACCESSORIES

Starrett MTL and MTH test frames may be equipped with a digital scale for measuring distance/deflection.

Horizontal mounting legs are available that allow the MTL-110, MTL-330 or MTH-550 to be operated in a horizontal configuration.

Bench clips may be used with FMM, FMS, FMD, MMS and MMD test frames. These clips help secure the test frames permanently to their work surface.

DIGITAL SCALE FOR MTL AND MTH FRAMES

- Includes mounting block
- Ensures proper alignment on a Starrett test frame



Digital Scale		
Model No.	Model Type	Supply
MTL-SCALE-110	MTL-110, MTL-330	1
MTL-SCALE-330	MTL-330	1
MTH-SCALE-550	MTH-550	1

HORIZONTAL MOUNTING LEGS

- Use with MTL-110, MTL-330 or MTH-55
- Includes all mounting hardware



Horizontal Mounting Legs		
Model No.	Model Type	Supply
MLX-10648	MTL-110, MTL-330, MTH-550	1

DIGITAL TEST FRAME BENCH CLIPS

- Use with FMM, FMS, FMD, MMS and MMD test frames
- Includes mounting hardware



Digital Test Frame Bench Clips		
Model No.	Model Type	Supply
L1-FMMCLIP	FMM	2
12745-0	FMS, FMD, MMS, MMD	1



SAFETY SHIELDS & EXTENSOMETERS

SAFETY SHIELDS

Optional safety shields are available for all motorized test frames. On FMS, MMS, FMD, and MMD models safety shields include an interlock, prevent tests from being run when the shield is open. All shields are constructed with aluminum frames and shatter-resistant aerospace acrylic.

Safety Shields		
Model No.	Description	Interlocks
FMM-S-SHIELD	FMM Safety Shield Short	No
FMM-SHIELD	FMM Safety Shield Standard	No
FMM-X-SHIELD	FMM Safety Shield Extended	No
FMS-1000 SHIELD	Safety Shield FMS-1000	Yes
FMS-2500 SHIELD	Safety Shield for FMS-2500 & FMS-5000	Yes
MMD-SHIELD	Safety Shield for MMD & FMD Test Frames	Yes



MMD Shield

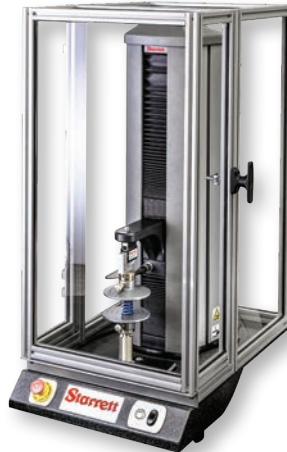

FMS Shield



FMM Shield

EXTENSOMETRY

Starrett offers a full range of contact-type extensometers. Our systems are compatible with Reliant Technologies® and Epsilon® extensometers and feature automatic identification of model and measuring range.

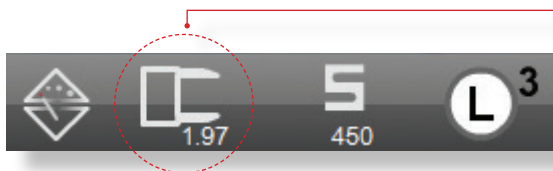

Starrett MMS and MMD material test frames may be used with extensometers. Starrett L3 systems may use extensometers from Reliant Technologies and Epsilon Technology Corporation.

Extensometers are customized so that they are automatically recognized by the L3 system. Selecting the Extensometer symbol will display key characteristics of the instrument including measuring range.



APPLICATIONS & SERVICES

APPLICATIONS

Adhesives



Important characteristics of adhesives, epoxies and materials that are bonded to one another can be measured using peel testing methods. Pressure-sensitive adhesive properties associated with materials such as labels, packaging products and medical wound management products, can be tested using a 180° testing method.

Building Materials



Materials used in building products, including asphalt and cement-based products can be tested to ascertain their strength and suitability under varying environmental conditions. Compressive and shear properties can be determined using L3 systems.

Ceramics



Ceramic and glass products are increasingly be used in a wide variety of products from cellular phones to fibre-optic cables. Because of their inherent brittleness, assessing their mechanical properties are important considerations, both in their design and application.

Biomedical



Testing medical devices and materials used in the production of medical devices are critical to ensure compliance to federal regulations. From the testing of latex products, syringes, stents, catheters to packaging products for medical devices, L3 systems can be used to verify and validate material compliance.

Composites

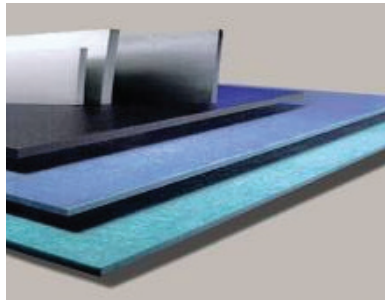

Composites are made by combining two or more materials- often materials with very different properties. Composites based on polymers continue to evolve and find their way into all kinds of products for aerospace and automotive applications to medical applications. Understanding stress and strain characteristics are critical in evaluation composites and their applicability.

Textiles



Fabric, yarn, filaments, cords and cloth are tested for strength and durability. Both natural and synthetic textiles are tested for strength and adhesion, tear strength, seam slippage and break strength.

Metals



Metals and alloys are tested under varying conditions. Tensile, compressive, shear, flexural and fracturing properties are important characteristics of all metals and alloys. Modulus, brittleness versus ductility, strength at offset yields are used to characterize these products and their ability to satisfy application and life-cycle requirements.

Plastics



The growth of plastics and polymers is exponential. Plastics are used everywhere in consumable materials to life-saving medical devices. Plastic properties are important in validating materials used in the development of products comprised of polymers. Tensile, compression, break/rupture/puncture and flexural testing are important characteristics in classifying plastics.

Rubber/Elastomers



Medical gloves, hoses used in automotive and aerospace products, foam, seals and building products are made from rubber and elastomer products. Compression strength, creep strength, puncture strength and tensile strength are important in assessing their suitability and manufacturability.

APPLICATIONS

COMMON TEST METHOD STANDARDS PERFORMED USING L3 SYSTEMS

ASTM TEST METHODS

A370	C469	D1876	D4268	D7136	E23	F2258
A48	C633	D1894	D429	D7137	E290	F2267
A615	C78	D2256	D4632	D7192	E399	F2346
A746	C880	D2261	D5034	D7269	E517	F2412
A938	C99	D2444	D5035	D790	E646	F2458
A996	D256	D2844	D5083	D882	E8	F2477
B557	D1002	D3039	D5250	D885	E813	F2516
C109	D1004	D2043	D5587	D903	E9	F2606
C1550	D1047	D3163	D575	D905	F1306	F382
C1609	D1238	D3364	D5766	E1012	F1614	F384
C165	D1335	D3763	D5930	E119	F1714	F543
C170	D1414	D3822	D6610	E1290	F1717	F606
C192	D143	D3835	D6272	E18	F2063	F88
C297	D1525	D3846	D6319	E1820	F2077	
C31	D1621	D4018	D638	E190	F2079	
C39	D1708	D412	D648	E208	F2255	
C42	D1761	D413	D695	E21	F2256	

ISO TEST METHODS

10319	13934-2	14879	2062	4587	6603-2	7800
11193-1	13937-2	15630-1	20795-1	527-1	6872	7886-1
11193-2	13937-3	15630-3	20795-2	527-2	6892-1	8067
1133	13937-4	16402	2307	527-3	6892-2	813
11339	14125	17744	2411	527-4	7206-4	8256-A
11343	14126	178	306	527-5	7206-6	8295
11443	14129	179-1	3133	604	7206-8	844
11897	14130	179-2	3183	6238	7438	9073-4
12737	1421	1798	34-1	6383-1	75	
13007-2	148	180	36	6475	75-1	
13934-1	14801	1926	37	6603-1	75-2	

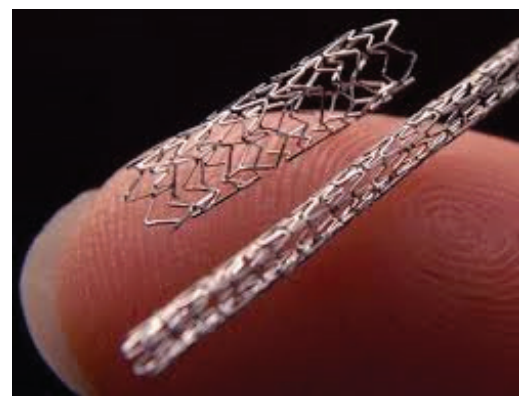
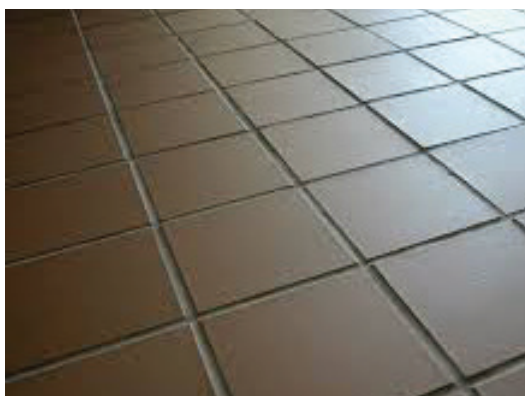

APPLICATIONS

STARRETT KNOWS FORCE ANALYSIS AND MEASUREMENT

Tensile testing



Identifying tensile force characteristics such as peak load is critical in validating a product's safety and application. Whether its consumer products, medical products, packaging materials or fasteners used in the building trades, tensile testing is a fundamental measurement available on all Lx systems.

Shear testing



Shear tests help measure the deformable mechanical properties of cosmetics, plastics, composites, fluids and other samples. Lap shear testing can be used to measure mechanical weld strength or the adhesive strength of epoxies.

Peel testing



Adhesive strength properties are measured to understand the bonding capabilities of coatings and glues on various types of materials- from paper to substrates to building materials. Both 90° and 180° testing can be performed to measure the peak holding strengths under standard test methods such as ASTM F88.

Compressive testing



Compressive loads are important in evaluating packaging designs, such as top load testing. Core sampling of concrete-based products are measured to determine their strength. And springs are analyzed under load to determine spring rate based on free length.

Flexural testing



Flexural strength and material stiffness represent the combined effects of a sample's basic tensile, compressive and shear characteristics. Composites, wood products, paper products can be tested in both 3- and 4-point methods to determine their stiffness and resilience.

Coefficient of friction testing



ASTM D1894 is a common test method for measuring coefficient of friction. Materials such as plastic sheeting can be tested to measure both the static and kinetic frictional characteristics. Other materials, such as flooring products are tested to determine their slip resistance and safety under various environmental conditions.

Break, Fracture and Rupture testing



Destructive testing can involve tensile, compressive, shear and other test methods where the product is tested to failure. Often this testing is used to determine the "peak" measurements that occur prior to the break event. Lx system allow you to measure precisely based on stress, strain, load, displacement and time.

Load rate testing



Load rate testing is a more complex testing method compared to testing to a setpoint at a specific velocity. Load rate testing can be used on consumer products, such as children's attire, to measure the pull strength of buttons and their resistance to breaking loads. Here the button is pulled at a rate (lbf/minute) rather than a time velocity (in/min).

Contact closure testing

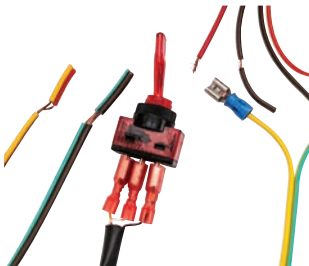

Using the optional Automation Builder, the "make and break" load for an electrical switch can be measured precisely. Load is applied to the switch and the peak load is measured when the switch closes/opens. This type of application can be tested on keypads, membranes and other materials that utilize a resistance change.

Insertion/Extraction testing



Insertion/extraction testing is performed on electronic components like jacks, medical devices, consumer products, and more. The loads are measured in both directions- tensile and compressive to determine the sample's characterization for the application and for product life-cycle determination.

Creep and Relaxation testing



Foam is a material where its deformation while under an applied load below its yield strength is measured and analyzed. Knowing the material's ability to maintain its specified deformation is important for comfort and longevity in its intended application.

APPLICATIONS

PACKAGING TESTING

T-Peel
90° Peel
180° Peel
Solder Paste Tackiness
ASTM F1140 - Burst Strength
ASTM D2659 - Top Load
ASTM F88 - Seal Strength
EN 868-5 - Seal Strength Pouches
ASTM C633 - Adhesion Spray Coating
ASTM D1335 - Tuft Binding Floor Covering
ASTM D903 - Adhesive Bond
ASTM D1876 - Peel Resistance
ISO 36 - Rubber Adhesion
ISO 2411 - Adhesion Plastic
ISO 4587 - Lap Shear Strength
ISO 11339 - Flexible Bond Assembly
EN 1465 - Lap Shear Strength
EN 1719 - Tack Measurement
EN 1939 - Peel Adhesion
Component Testing
Compress (Load/Extension)
Compress (Stress/Strain)
Indentation (Load/Extension)
Indentation (Stress/Strain)
Spring Rate
Spring Force
Spring Height

MEDICAL DEVICE TESTING

ASTM F88 - Seal Strength
ASTM F382 - Metallic Bone Plates
ASTM F451 - Bone Cement Strength
ASTM F564 - Metallic Bone Staples
ASTM F1828 - Ureteral Stents
ASTM F1839 - Foam Devices
ASTM F1874 - Sutures Bend Test
ASTM F2079 - Stents Tensile Strength
ASTM F2132 - Puncture Resistance
ASTM F2183 - Punch Testing
ASTM F2255 - Lap Shear Testing
ASTM F2256 - Tissue Adhesives
ASTM F2258 - Tissue Adhesives
ASTM F2392 - Burst Strength Sealant
ASTM F2458 - Closure Strength
ASTM F2477 - Stents Strength
ASTM F2502 - Plates and Screws
ASTM F2516 - Tensile Nitinol Wire
ASTM F2606 - Bend Vascular Stent
ASTM D6319 - Medical Gloves
BS EN 455-2 - Medical Gloves
ISO 7886-1 - Hypodermic Syringe
ISO 14879 - Tibial Trays
ISO 11193 - Medical Glove

COMPRESSION TEST

Tensile Test
Tensile Strength
ASTM D3039 - Tensile Carbon Fiber
ASTM D3846 - Shear Strength
ASTM D7269 - Aramid Cords
ASTM D6484 - Compressive Strength
ASTM D1055 - Flex Resistance
ASTM D3574 - Indentation Deflection
ASTM D3574 - Foam Deflection
EN 14509 - Shear Strength
ISO 527-4 - Tensile Isotropic/Orthotropic
ISO 14125 - Flexural Properties
ISO 14126 - In-plane Compression
TAPPI - 404 - Tensile Break Strength
TAPPI 220 - Burst Strength
TAPPI 456 - Wet Paper Strength
TAPPI 457 - Pull to Rupture

SERVICES

CALIBRATION, FIELD SERVICE, FACTORY SERVICE

Starrett and our global network of service providers can provide all levels of service for your material test and force measurement systems. We can supply a comprehensive range of calibration and verification services to ensure that your testing meets the requirements of international testing standards. Calibrations can be performed to ASTM E4 for load and ASTM E2658 for displacement or to equivalent standards from ISO, BS, DIN and more. Speed, stress and strain verifications can be performed on-site by technicians accredited to ISO 17025.

Preventative maintenance programs, field and factory repair services are available to ensure that your systems perform to their published specifications.

Starrett can provide factory services including load cell calibrations, test frame repair and reconditioning. All Starrett load cell sensors are supplied with a NIST-traceable Certificate of Calibration.

Specialized services, including system integration with existing instrumentation, or application development for complex testing applications can be supplied by your Starrett representative.

Your Starrett representative can provide on-site training to your personnel to help ensure that your system operates to its published specification. Our training also provides your operators with the knowledge needed to perform your testing in a safe and efficient manner. Our objectives are to help you make your products better through improved resource utilization, increased throughput and optimized efficiency.



Starrett stocks critical spare parts and accessories for quick delivery. Load cell sensors and commonly used test fixtures are readily available.



Field and factory calibrations are performed by authorized Starrett service technicians to accepted industry standards and methodology. All calibrations are NIST-traceable.

FORCE AND MATERIAL TESTING TERMINOLOGY

Terms	Description
Load	Load is a common term used in place of a force exerted on a surface or a body, it is often expressed in either N (Newton, 1 kg * m/s ²), LBF (pounds force), KGF (kilograms force). On a force measurement machine load is measured with a Load Cell Sensor.
Stress	Stress is a measurement of force (load) per unit area. It is often denoted by "σ" (sigma). To calculate stress you will need to know force and area of the sample being tested. Stress is expressed in either PSI (Pounds per inch ² , lbf/in ²), KSI (Kilograms per inch ² , kg/m ²), or MPa (Mega Pascal, 1 Pascal = N/m ²).
Strain	Strain is the amount of deformation of a sample compared to the sample's original size. It is often denoted by "ε" (epsilon). Strain values are unit-less (because in the ratio the units cancel themselves out). However, it can be expressed by a percentage or referred to as "stains".
Elasticity	Elasticity is the ability of a material to return to its original shape when a load causing deformation is removed. An Elastic material will obey Hooke's Law where Stress is directly proportional to Strain. Springs are supposed to obey Hooke's Law.
Plasticity	Plasticity describes when a material tends to remain deformed even after reducing the Stress that caused the original deformation. A plastic material will retain its shape once the load causing the deformation is removed. Plasticity is closely associated with malleability where a material can be "worked" or "hammered" into a permanent shape.
Stiffness	Stiffness is the resistance of an elastic material to deformation after an applied load.
Elongation	Often associated with ductility, Elongation is the increase in gauge length divided by the original gauge length. Elongation is typically expressed as a %.
Extension	Extension is the measurement of distance, Extension is sometimes called Deflection and is expressed in either; IN (Inch), MM (millimeter), or % (percent elongation). On a force measurement machine extension can be measured with an internal encoder or using an ancillary extensometer.
Modulus of Elasticity	Also referred to as Young's Modulus. It is the rate of change of Stress as a function of Strain. It characterizes materials as a measure of their stiffness. It is calculated as the slope of the line before the proportional limit.
Proportional Limit	The highest Stress at which the curve in a Stress/Strain diagram is a straight line.
Axial Load	The load applied to the primary axis. Sensors have a "live" side, e.g. the side where load is to be applied. Incorrect loading WILL result in erroneous readings.
Full Scale Deflection	The mechanical deflection produced by the load sensor when maximum (full scale) load is applied. All load cells deflect when load is applied.
Temperature Compensation	Load cells are affected by temperature which can impact Zero Balance. Our sensors are temperature compensated. Its "good practice" to allow the load sensor to "warm up" (5 minutes) prior to use.
Capacity	The maximum axial load a load cell sensors is designed to measure within its specification.
Span	Another term used to express the sensor's maximum rated output.
Zero or Zero Balance	The signal of the load cell when no load is applied.
No Load	The condition of the load cell, when in its correct orientation, and with no load applied and no fixtures attached.
Mode	Starrett load cells will operate in Tension and Compression modes.
None-linearity	The algebraic difference between output at a specified load and the corresponding point along a straight line drawn between minimum load and maximum load. Normally expressed as %FS (Full Scale).
Hysteresis	The algebraic difference between output at a given load descending from maximum load and output at the same load ascending from minimum load.
TEDS	Short for Transducer Electronic Data Sheet, TEDS chips allow Starrett load cells to be self-identifying, this "Plug & Play" ability minimizes system setup time and stores sensor calibration data
NIST Certification	National Institute of Standards and Technology. Starrett load cells are supplied with a Certificate of Calibration traceable to NIST.
ASTM E4	AKA: American Society for Testing and Materials. E4 is the "Standard Practices for Force Verification of Testing Machines".
ASTM E83	is the "Standard Practice for Verification and Classification of Extensometer Systems". Normally, ASTM E4 is required for a Material Test System, but NOT necessary for a Force Measurement Test System.

COMMON COMPRESSION SPRING TERMINOLOGY

Symbol	Units	Description	Formula
D	mm, in	Mean diameter	$D = D_e - d$
D_e	mm, in	External diameter	$D_e = D + d$
D_i	mm, in	Internal diameter	$D_i = D - d$
d	mm, in	Wire diameter	$d = D_e - D$
E	Mpa, PSI	Modulus of elasticity	$E = \delta/\epsilon$
L1, L2	N, Lbf	Target loads (related to target heights/lengths)	
$F_c Th$	N, Lbf	Theoretical load/force at set solid	
F_n	N, Lbf	Load/force related to L_n (smaller length)	
f_e	Hz	Natural frequency	
k	-	Stress correction factor	
L_0, FL	mm, in	Free length/height	
D_1, D_2	mm, in	Target Length/distance (related to target loads)	
L_c	mm, in	Solid length	$L_c = d(n+ni+nm)$
L_d	mm, in	Length of wire	$L_d = \pi D [2 + nm + n / \cos(z)]$
LK	mm, in	Buckling length	
L_n	mm, in	Smallest allowed operating length (geometric)	$L_n = d(n + ni + nm) + S_a$
L_r	mm, in	Smaller allowed operating length (stress)	
M	g, lb	Mass	$M = L_d \rho \pi d^2 10^{-3} / 4$
m	mm, in	Spring pitch	$m = [L_0 - d(ni + nm)] / n$
N		Number of cycles	
n		Number of active coils	$n = G d^4 / (8 R D^3)$
n_i		Coils related to the ends	
n_m		Number of dead coils	
n_t		Total number of coils	$n_t = n + n_m + 2$
R, KSR	N/mm, Lbf/in	Spring Rate	$R = G d^4 / (8 n D^3)$ or $(L_1 - L_2) / (D_1 - D_2)$
R_m	Mpa, PSI	Ultimate tensile strength	
Sh	mm, in	Spring travel	$Sh = D_1 - D_2$
W	Nmm, Joule	Stored energy	$W = 0.5(L_1 + L_2)(D_1 - D_2)$
w	-	Spring index	$w = D / d$

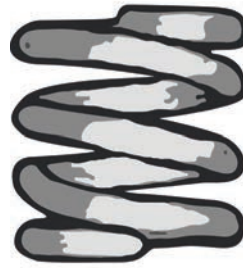

Closed and Squared

Closed and squared end compression springs are the most common. This end type allows the spring to stand vertically when placed on a flat surface. The last coil on either end is closed. This end type is suited for compression springs with a low slenderness ratio.



Closed and Ground

Closed and ground ended compression springs are also common but they are more expensive. Closed and ground ends will help your compression spring stand vertically straight on a flat surface when the slenderness ratio is too large.



Double Closed

Double closed ends are very similar to closed and squared ended compression springs. Instead of the spring having one closed coil at the ends, it has two. They are used to provide stability when your spring has a high slenderness ratio. This end type helps prevent buckling.



Open Ended

Open ended compression springs are uncommon since the spring will not be able to stand unless supported by a shaft or mandrel. There is a pitch between each coil on an open ended compression spring.

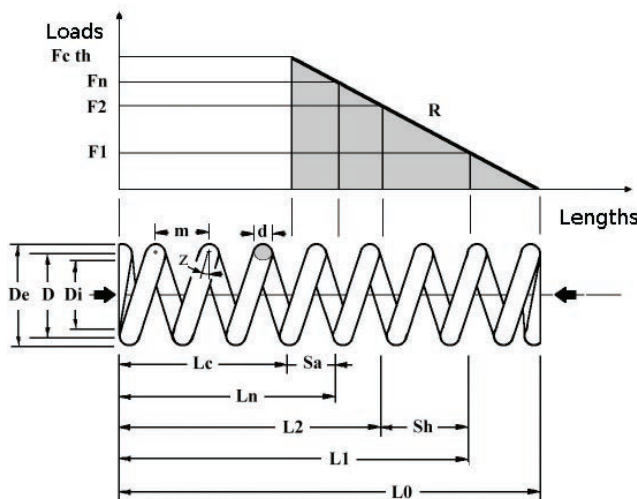

COMMON SPRING DESIGN MATERIALS

Material	Stress	Corrosion Resistance	Application
Brass	Low	Yes	Water resistant
Phosphor Bronze	Low	Yes	Electrical connectivity
Stainless Steel (302/304)	Low	Yes	Corrosive environments
Oil Tempered	Medium	No	Large diameters
Hard Drawn MB	Medium	No	Low cost
Music Wire	High	No	High stress

COMMON EXTENSION SPRING TERMINOLOGY

Symbol	Units	Description	Formula
A_{L0}	mm, in	Free length tolerance	
D	mm, in	Mean diameter	$D = D_e - d$
D_e	mm, in	External diameter	$D_e = D + d$
D_i	mm, in	Internal diameter	$D_i = D - d$
d	mm, in	Wire diameter	$d = D_e - D$
E,	Mpa, PSI	Modulus of elasticity	$E = \delta/\epsilon$
F0	N, Lbf	Initial tension	$P_i = 2P_1 - P_2$
L1, L2	N, Lbf	Target loads (related to target heights/lengths)	
FcTh	N, Lbf	Theoretical load/force at set solid	
Fn	N, Lbf	Load/force related to Ln (smalled length)	
fe	Hz	Natural frequency	
k	-	Stress correction factor	
L0, FL	mm, in	Free length/height	
D1, D2	mm, in	Target Length/distance (related to target loads)	
Lc	mm, in	Solid length	$L_c = d(n+ni+nm)$
Ld	mm, in	Length of wire	$L_d = \pi D [2 + nm + n / \cos(\alpha)]$
LK	mm, in	Buckling length	
Ln	mm, in	Smallest allowed operating length (geomometric)	$L_n = d(n + ni + nm) + S_a$
Lr	mm, in	Smalled allowed operating length (stress)	
M	g, lb	Mass	$M = L_d \rho \pi d^2 10^{-3} / 4$
m	mm, in	Spring pitch	$m = [L_0 - d(ni + nm)] / n$
N		Number of cycles	
n		Number of active coils	$n = G d^4 / (8 R D^3)$
ni		Coils related to the ends	
nm		Number of dead coils	
nt		Total number of coils	$nt = n + nm + 2$
R, KSR	N/mm, Lbf/in	Spring Rate	$R = G d^4 / (8 n D^3)$ or $(L_1 - L_2) / (D_1 - D_2)$
Rm	Mpa, PSI	Ultimate tensile strength	
Sh	mm, in	Spring travel	$Sh = D_1 - D_2$
W	Nmm, Joule	Stored energy	$W = 0.5(L_1 + L_2)(D_1 - D_2)$
w	-	Spring index	$w = D / d$

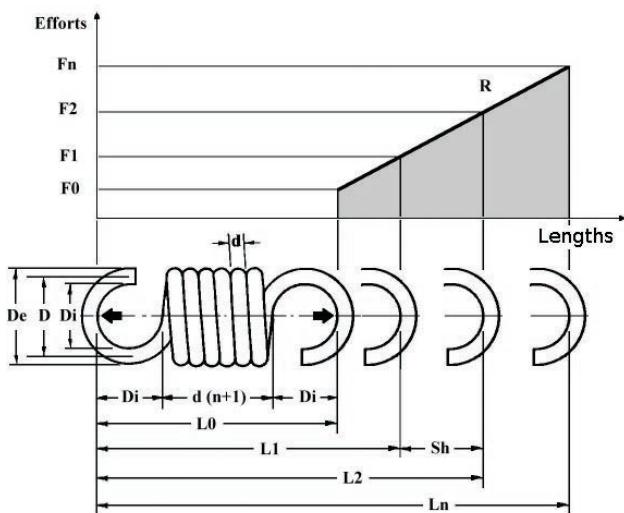

Hooks and Loops

Extension springs make use of hooks or loops. Loops are closed while hooks have an open side or section.



No Hooks

These types of ends have o stress or fatigue on the ends of the extension spring. The amount of pulling force and distance increases and the life cycles re longer. No hooks have the ability to use a bolt to thread into the inner diameter of the extension or tension spring thus securing the ends of the spring

Machine Hook and Loop

Machine hooks are a common type of extension spring hook. These hooks are stronger than cross over center hooks because the radius of the bend to make the hook is not as pronounced.



Crossover Center Hooks

Crossover center type extension springs are very common. This type of hooks is made by lifting the last coil and twisting the coil towards the middle therefore crossing the center.

Extended Hooks

Extended hook extension springs are very useful when you need a long length inside hooks but a short body length to get more force out of the spring through less coils. It is the most expensive hook type.



Side Hooks

This hook type is used when the body of the spring must not interfere with the components of a mechanism. This is due to the fact that the hooks are on one side of your spring therefore the other side of the spring is offset. They are made by simply bending the last coil so they are more economical than cross over center hooks

GLOSSARY OF SPRING TERMS

Terms	Description
Active Coils	The coils that are free to deflect when under load.
Allow for Set	Spring is supplied longer than specified to compensate for length loss when fully compressed.
Angular Relationship to Ends	The relative position of the plane of the hooks or loops of extension springs to each other.
Buckling	Bowing or lateral deflection of compression springs when compressed, related to the slenderness ratio (L/D).
Closed Ends	Ends of compression springs where pitch of the end coils is reduced so that the end coils touch.
Closed & Ground Ends	Same as with closed ends, except that the end is ground to provide a flat plane.
Closed Length	Also called Solid Height. Height of a compression spring when under sufficient load to bring all the coils into contact with adjacent coils.
Close-Wound	Coiled with adjacent coils in contact.
Coils per Inch	Also called Pitch. The distance from center to center of the wire in adjacent active coils (recommended practice is to specify number of active coils rather than pitch).
Deflection	Motion of spring ends or arms under the application or removal of an external load.
Elastic Limit	Maximum stress to which a material may be subjected without producing permanent set.
Endurance Limit	Maximum stress at which any given material will operate indefinitely without failure for a given minimum stress.
Free Length	The overall length of a spring in the unloaded position.
Gradient	Also called Rate. Change on load per unit deflection, generally given in pounds per inch or Newtons per millimeter.
Helix	The spiral form (open or closed) of compression, extension and torsion springs.
Hooks	Open loops or ends of extension springs.
Hysteresis	The mechanical energy loss that always occurs under cyclic loading and unloading of a spring, proportional to the area between the loading and unloading load-deflection curves within the elastic range to a spring.
Initial Tension	The force that keeps the coils of an extension spring closed and which must be overcome before the coils start to open.
Load	The force applied to a spring that causes a deflection.
Loops	Coil-like wire shapes at the end of extension springs that provide for attachment and force application.
Mean Coil Diameter	Outside spring diameter (O.D.) minus one wire diameter.
Modulus in Shear	Coefficient of stiffness for extension and compression springs.
Modulus in Tension	Coefficient of stiffness used for torsion and flat springs (Young's Modulus).
Moment	Also called Torque. A twisting action in torsion springs which tends to produce rotation, equal to the load multiplied by the distance (or moment arm) from the load to the axis of the spring body. Usually expressed in inch-oz., inch-pounds or foot-pounds.
Open Ends. Not Ground	End of a compression spring with a constant pitch for each coil.
Open and Ground End	"Open ends, not ground" followed by an end grinding operation.
Permanent Set	A material that is deflected so far that its elastic properties have been exceeded and it does not return to its original condition upon release of load is said to have taken a "permanent set".
Pitch	The distance from center to center of the wire in adjacent active coils (recommended practice is to specify number of active coils rather than pitch).
Preset	Full compression of a spring to solid state by manufacturer when needed to prevent length loss in operation.
Rate	Change on load per unit deflection, generally given in pounds per inch or Newtons per millimeter.
Remove Set	Full compression of a spring to solid state by manufacturer when needed to prevent length loss in operation.
Residual Stress	Stresses induced by set removal, shot peening, cold working, forming and other means. These stresses may or may not be beneficial, depending on the application.
Set	Length loss in operation due to the high stress condition of the spring.
Slenderness Ratio	Ratio of spring length (L) to mean coil diameter (D).
Solid Height	Height of a compression spring when under sufficient load to bring all the coils into contact with adjacent coils.
Spring Index	Ratio of the mean coil diameter (D) to wire diameter (d).
Stress Range	The difference in operating stress at minimum and maximum loads.
Stress Relieve	To subject springs to low-temperature heat treatment so as to relieve residual stresses.
Shot Peened	A cold working process in which the material surface is peened to induce compressive stresses and thereby improve fatigue life.
Squareness of Ends	Angular deviation between the axis of a compression spring and a normal to the plane of the ends.
Squareness Under Load	Same as Squareness of Ends, except with the spring under load.
Torque	A twisting action in torsion springs which tends to produce rotation, equal to the load multiplied by the distance (or moment arm) from the load to the axis of the spring body. Usually expressed in inch-oz., inch-pounds or foot-pounds.
Total Coils	Number of active coils (n) plus the coils forming the ends.
Wahl Factor	A factor to correct stress in helical springs effects of curvature and direct shear.

- A**
Applications181-185
- B**
Button Fixtures105-106
- C**
Cables 173-174
L1-CONTROL Cable182
L1-RS232 Cable182
USB Cables182
Clevis Adapters165-167
Coefficient of Friction 151-153
- D**
Digital Force Gages 13-17
- E**
Eccentric Rollers 67-72
- F**
Flexural Fixtures107-109
Food Texture Fixtures155-159
Force Gage Adapters169-172
Chisel Adapters170
Extension Rods171
Flat Adapters170
Force Gage Accessory Kits171
Notch Adapters170
Point Adapters170
Threaded Adapters172
- G**
Gage Adapter Plates and Mounting Blocks 175-176
Force Gage Adapter Plates176
Mounting Blocks176
- H**
Hook Adapters 161-163
Clevis Hooks 162
Threaded Hooks 163
Threaded Hook Swivel Adapter 163
- L**
Load Cell Sensors53-55
- M**
Manual Test Stands 19-21
Motorized Test Stands23-32
- P**
Peel Fixtures 111-118
Platens 57-65
Circular Platens59-61
Rectangular Platens 62-64
Self-Alignment Platens65
Pneumatic Fixtures 119-142
- R**
Rope and Bollard Fixtures 99-104
- S**
Safety Shields and Extensometers179-180
Scissor Fixtures 147-150
Services 186
Spring Test Fixtures 143-144
Software 33-60
LX35
L336-39
L2Plus 40-43
L144-51
Automatic Builder 50-51
Digital Force Controller52
Syringe Test Fixtures 145-146
- T**
Terminology 195-198
Tester Accessories177-178
- V**
Vise-Action Fixtures 73-91
- W**
Wedge-Action Fixtures93-98

CONTACT INFORMATION GUIDE FOR NORTH AMERICA

COMPLETE, UP-TO-DATE CONTACT INFORMATION AVAILABLE AT STARRETT.COM

PRIMARY CONTACTS, SALES AND GENERAL INFORMATION

- **World Headquarters and Precision Tools:**
Athol, MA, (978) 249-3551
- **Metrology Equipment:**
Laguna Hills, CA, (949) 348-1213
- **Laser Measurement:**
Columbus, GA, (706) 323-5142
- **Granite Surface Plates and Accessories:**
Waite Park, MN, (320) 251-7171
- **Gage Blocks:**
Cleveland, OH, (440) 835-0001
- **Mexico:**
Saltillo, Coah, Mexico, (844) 432-4660

CALIBRATION

- **Precision Tools and Gages:**
Athol, MA, (978) 249-3551
- **Starrett Calibration Services:**
Duncan, SC, (864) 433-8407
- **Metrology Equipment:**
Laguna Hills, CA, (949) 348-1213
- **Granite Surface Plates and Accessories:**
Waite Park, MN, (320) 251-7171
- **Gage Blocks:**
Cleveland, OH, (440) 835-0001
- In Mexico, please call (844) 432-4660

REPAIR

- **Precision Tools and Gages:**
Athol, MA, (978) 249-3551
- **Metrology Equipment:**
Laguna Hills, CA, (949) 348-1213
- **Granite Surface Plates and Accessories:**
Waite Park, MN, (320) 251-7171
- **Gage Blocks:**
Cleveland, OH, (440) 835-0001
- In Mexico, please call (844) 432-46-60

CUSTOM SOLUTION DEVELOPMENT

- **Special Tools and Gages:**
Athol, MA, (978) 249-3551
- **Metrology System Development and Configuration:**
Laguna Hills, (949) 348-1213
- **Granite Based Custom Products:**
Waite Park, MN, (320) 251-7171
- In Mexico, please call (844) 432-4660

ADDITIONAL AND/OR UP-TO-DATE INFORMATION

- starrett.com
- Product Literature and Educational Materials:
- Select the "Catalogs" button at starrett.com to order printed product information and to access literature PDFs for viewing and/or downloading
- In Mexico, please call (844) 432-4660



CORPORATE HEADQUARTERS AND MAIN FACTORY

THE L.S. STARRETT COMPANY

121 Crescent Street
Athol, MA 01331-1915 - U.S.A.

Tel: (978) 249-3551
Main Fax: (978) 249-8495

INTERNATIONAL LOCATIONS

BRAZIL

Starrett Indústria e Comércio Ltda.
Av. Laroy S. Starrett 1880 - Bairro Pinheirinho
Caixa Postal 171
13306-900 Itu, São Paulo - Brazil

Tel: 55 11 2118-8200
Fax: 55 11 2118-8003

SCOTLAND

The L.S. Starrett Company Ltd.
Jedburgh TD8 6LR - Scotland

Tel: 44 (0) 1835 863501
Fax: 44 (0) 1835 863018

CHINA

Starrett Tools (Suzhou) Company Limited
Suzhou Industrial Park
No. 339. Su Hong Zhong Road
Suzhou, Jiangsu Province
P.R. China 215021

Tel: 86 512 6741940
Fax: 86 512 67415697



HOW TO ORDER

For prompt delivery, technical support and assistance, contact your nearest industrial distributor.

PRODUCT DEMONSTRATION

All Starrett manufacturing and branch locations and many distributors can demonstrate an array of Starrett products at work. Contact your local distributor to learn more.



STARRETT PRODUCT LINES

Band Saw Blades

Force Measurement

Jobsite & Workshop Tools

Laser Measurement

Metrology Equipment

Precision Granite

Precision Ground Solutions

Precision Measuring Tools

PTA & Hand Tools

Service

Webber Gage Blocks

FORCE AND MATERIAL TESTING



DISA AG Sarnen

www.disa.ch | info@disa.ch | T: +41 41 666 70 50



Phone: (978) 249-3551 | Fax: (978) 249-8495
121 Crescent Street-Athol, MA 01331-1915-USA